



TECHNICAL DATA

HIGH-MU
POWER TRIODE

The EIMAC 3CPX1500A7 is a rugged ceramic/metal high-mu power triode, designed with beam-forming cathode and control-grid geometry to allow the simplicity of design and circuit advantages of a triode with the gain of a tetrode.

The 3CPX1500A7 is intended for pulse modulator or pulse regulator service, with a pulse plate current rating of 50 amperes, and a voltage holdoff rating of 10,000 volts in air, with forced-air cooling of the anode, or 15,000 volts when immersed in a suitable dielectric liquid which is also used for tube cooling.

An Air-System Socket (EIMAC SK-2200) and an Air Chimney (EIMAC SK-2216) are available for those applications requiring forced-air cooling.

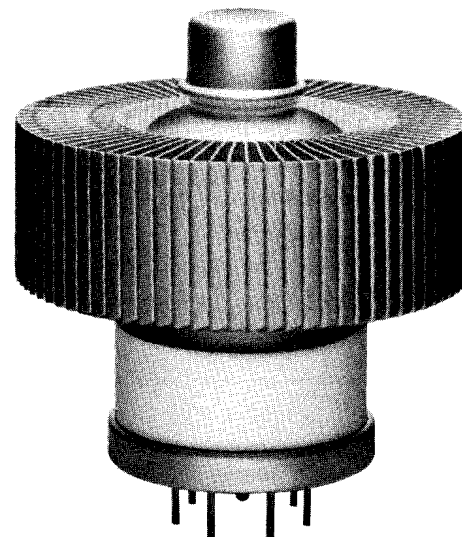

GENERAL CHARACTERISTICS¹

ELECTRICAL

Cathode: Oxide Coated, Unipotential

Heater: Voltage	5.5 ± 0.25 V
Current, at 5.5 volts	11.2 A
Transconductance (Average, with I _b = 1.0 Adc)	55,000 μmhos
Amplification Factor (Average)	200
Direct Interelectrode Capacitance (grounded cathode) ²	
C _{in}	38.5 pF
C _{out}	0.1 pF
C _{gp}	10 pF

1. Characteristics and operating values are based upon performance tests. These figures may change without notice as the result of additional data or product refinement. EIMAC Division of Varian should be consulted before using this information for final equipment design.

2. Capacitance values are for a cold tube as measured in a special shielded fixture in accordance with Electronic Industries Association Standard RS-191.

MECHANICAL

Maximum Overall Dimensions:

Length	4.02 in; 102 mm
Diameter	3.38 in; 86 mm
Net Weight	26 oz; 735 gm
Operating Position	Any
Maximum Operating Temperature, Ceramic/Metal Seals or Anode Core	250° C
Cooling	Forced Air or Liquid Immersion



Base	Special 7-Pin
Recommended Air-System Socket	EIMAC SK-2200
Recommended Air Chimney	EIMAC SK-2216

RANGE VALUES FOR EQUIPMENT DESIGN

	<u>Min.</u>	<u>Max.</u>
Heater: Current at 5.5 volts	10.2	12.2 A
Cathode Warmup Time	90	--- sec
Interelectrode Capacitance (grounded cathode connection) ¹		
C _{in}	36.0	41.0 pF
C _{out}	---	0.2 pF
C _{gp}	9.2	11.2 pF

1. Capacitance values are for a cold tube as measured in a special shielded fixture in accordance with Electronic Industries Association Standard RS-191.

PULSE MODULATOR OR SWITCH TUBE SERVICE

TYPICAL OPERATION - Pulse Modulator Service

ABSOLUTE MAXIMUM RATINGS:

	<u>In Air</u>	<u>In Oil</u>	
HEATER VOLTAGE	5.5±5%	5.5±5%	VOLTS
DC PLATE VOLTAGE	10.0	15.0	KILOVOLTS
DC GRID VOLTAGE	-200	-200	VOLTS
PEAK PLATE CURRENT ¹	50	50	AMPERES
PULSE LENGTH & DUTY ¹	See Derating Chart		
PLATE DISSIPATION ²	1500	1500	WATTS
GRID DISSIPATION	25	25	WATTS

Plate Voltage	10.0	15.0 kVdc
Pulse Plate Current	40	40 a
Grid Voltage	-125	-150 Vdc
Pulse Positive Grid Voltage ³	340	340 v
Pulse Grid Current ³	1.5	1.5 a
Pulse Duration	2.0	2.0 μs
Duty	0.0006	0.0006
Pulse Driving Power ³	697	735 w
Pulse Output Power ³	306	506 kw
Pulse Output Voltage ³	7.68	12.68 kv

1. Pulse length, pulse plate current, and duty are interrelated; see Derating Chart.
2. Plate dissipation values shown are nominal; capability is dependent on cooling technique and equipment design. In all cases the ABSOLUTE MAXIMUM

- temperature ratings should not be exceeded, and for best life and consistent performance operation at lower temperatures is normally beneficial.
3. Approximate value.

APPLICATION

MECHANICAL

MOUNTING - The 3CPX1500A7 may be operated in any position. The SK-2200 socket is designed to hold the tube and make all base contacts, and for applications where forced-air cooling is to be used, the matching air chimney, SK-2216 is available.

COOLING - The 3CPX1500A7 may be either forced-air cooled or liquid-immersion cooled in a

suitable dielectric coolant fluid. The maximum temperature limit for external tube surfaces and the anode core is 250°C, but it should be noted that, where long life and consistent performance are important design factors, operation at somewhat lower temperatures is normally beneficial. The air cooling data shown will maintain tube temperatures below 225°C with 50°C cooling air.

When the tube is liquid-immersed, circulation of the dielectric fluid will normally be required and the designer is cautioned to assure sufficient tube cooling for the maximum dissipation level likely to ever be reached with some safety factor allowance.

Base-to-Anode Air Flow (sea level)		
Anode Dissipation (watts)	Air Flow (CFM)	Pressure Drop In./H 0
500	7.5	0.10
1000	22.5	0.20
1500	35	0.41
Base-to-Anode Air Flow (10,000 ft.)		
Anode Dissipation (watts)	Air Flow (CFM)	Pressure Drop In./H 0
500	11.0	0.15
1000	32.5	0.29
1500	51	0.60

Note: 1) Tube mounted in SK-2200 Socket with SK-2216 Chimney.

2) An allowance of 25 watts has been made for grid dissipation and 50 watts for filament power.

ELECTRICAL

FILAMENT/CATHODE OPERATION - Pulse current capability of the 3CPX1500A7 is dependent on cathode temperature, which in turn is dependent on heater voltage. When the full rated ($i_b=50$ amperes maximum) anode current is required, the heater voltage should be operated at 5.5 volts and not deviate from this nominal value by more than plus or minus five percent. When a lower value of anode current ($i_b=24$ amperes maximum) is adequate for the application, the heater voltage should be reduced to 5.0 volts, plus or minus five percent, and tube life expectancy will be greatly improved. In cases where better life expectancy and consistent performance are factors, regulation to better than five percent will normally be beneficial at either heater voltage level. Voltage should be measured with a know accurate rms-responding meter.

ANODE CURRENT - For pulse service, either as a switch tube or modulator, or for voltage regulator applications, an anode current (during the pulse) of up to 50 amperes is available, with $E_f=5.5$ volts, or up to 24 amperes with $E_f=5.0$ volts. Peak current capability, pulse length, and duty factor are interrelated and the PULSE DERATING DATA should be consulted. For pure dc service, the anode current should be limited to 1.0 ampere.

HIGH VOLTAGE - For air operation, anode voltage should not exceed 10 kVdc at sea level. This value allows some safety factor, but does assume a clean tube with no buildup of dirt or grime across the insulating ceramic. At higher altitudes a reduction in voltage may be required to preclude the possibility of external tube flashover. When the tube is immersed in a liquid dielectric coolant with suitable insulating properties the allowable anode voltage is 15 kVdc at any altitude.

The operating voltages for this tube must be considered as potentially lethal and the equipment must be designed properly and operating precautions must be followed. The equipment must include safety enclosures for the high-voltage circuits and terminals, with interlock switches to open the primary circuits of the power supplies and to discharge high voltage condensers whenever access doors or covers are opened. Interlock switches must not be bypassed or "cheated" to allow operation with access doors open. Always remember that HIGH VOLTAGE CAN KILL.

PLATE SURGE-LIMITING IMPEDANCE - Tubes such as the EIMAC 3CPX1500A7 are built with closely spaced electrodes. This results in high voltage gradients even at normal operating voltages. A high-energy arc-over between electrodes may be destructive, and therefore a series impedance in the anode lead is recommended, or the anode supply should be designed so that it has sufficient self impedance to limit the short-circuit current to 10 times the maximum pulse-current rating. Normal overload protection techniques should also be used in the anode circuit to prevent tube damage, in the event of a fault condition.



X-RADIATION HAZARD - High-vacuum tubes operating at voltages higher than about 10 kilovolts produce progressively more dangerous X-ray radiation as the voltage is increased. The 3CPX-1500A7, operating at its rated voltages and currents, is a potential X-ray hazard, with only limited shielding afforded by the tube envelope. Moreover, the X-ray radiation level can increase significantly with aging and gradual deterioration, due to leakage paths or emission characteristics as they are affected by the high voltage. X-ray shielding must be provided on all sides of tubes operating at these voltages to provide adequate protection throughout the tube's life. Periodic checks on the X-ray level should be made, and the tube should never be operated without adequate shielding in place when voltages above 10 kilovolts are in use. Lead glass, which attenuates X-rays, is available for viewing windows. If there is any doubt as to the requirement for or the adequacy of shielding, an expert in this field should be contacted to perform an X-ray survey of the equipment.

Operation of high-voltage equipment with interlock switches "cheated" and cabinet doors open in order to be better able to locate an equipment malfunction can result in serious X-ray exposure.

GRID OPERATION - The maximum rated dc grid bias voltage for the 3CPX1500A7 is -200 Vdc and the maximum grid dissipation rating is 25 watts. In normal applications the grid dissipation will not approach the maximum rating.

The circuit designer should be aware that grid secondary emission effects typically occur with a tube of this size and must be considered. This effect has to do with tube geometry, the metals used in such grid structures and operating potentials. The CONSTANT CURRENT CHARACTERISTICS plots (see Page 7 and 8) show both positive and negative (secondary) grid current flow as being typical.

A driver stage which works into such a non-linear load normally must be designed in such a manner as to tolerate this condition, such as swamping the drivers so that the change in load due to forward or reverse grid currents is a small percentage of the total load the driver works into.

PLATE OPERATION - The anode of the 3CPX-1500A7 is nominally rated for the dissipation values shown on Page 2 depending on the type of cooling used. When the tube is immersed in a

liquid dielectric coolant, with proper circulation, and (if required) provisions for dielectric fluid cooling, dissipation capability is actually limited only by tube temperature, especially in the seal areas and the anode core.

In pulse service average anode dissipation may be calculated as the product of pulse anode current, pulse tube-voltage drop during conduction, and the duty factor. Actual dissipation may often exceed the calculated value, however, if pulse rise and fall times are appreciable compared to pulse duration. This occurs because long rise and fall times allow plate current to flow for longer periods in the high tube-voltage-drop region.

INTERELECTRODE CAPACITANCE - The actual internal interelectrode capacitance of a tube is influenced by many variables in most applications, such as stray capacitance to the chassis, capacitance added by the socket used, stray capacitance between tube terminals, and wiring effects. To control the actual capacitance values within the tube, as the key component involved, the industry and the Military Services use a standard test procedure as described in Electronic Industries Association Standard RS-191. This requires the use of specially constructed test fixtures which effectively shield all external tube leads from each other and eliminates any capacitance reading to "ground". The test is performed on a cold tube. Other factors being equal, controlling internal tube capacitance in this way normally assures good interchangeability of tubes over a period of time; manufacturer's technical data, or test specifications, normally are taken in accordance with Standard RS-191.

The equipment designer is therefore cautioned to make allowance for the actual capacitance values which will exist in any normal application. Measurements should be taken with the socket and mounting which represent approximate final layout if capacitance values are highly significant in the design.

SPECIAL APPLICATIONS - If it is desired to operate this tube under conditions widely different from those given here, write to Power Grid Tube Product Manager, EIMAC Division of Varian, 301 Industrial Way, San Carlos, California 94070 for information and recommendations.

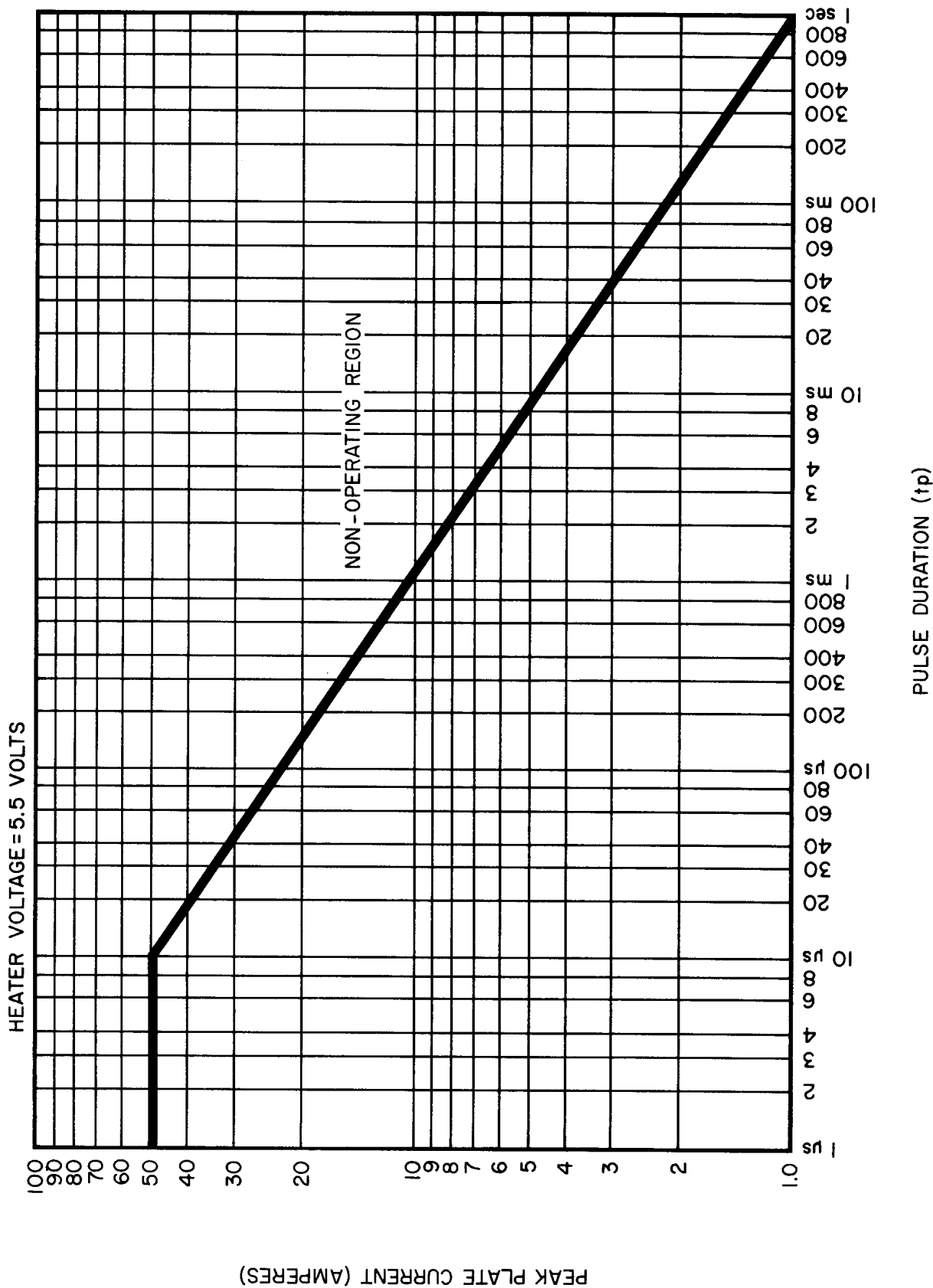

PULSE DERATING DATA, TYPE 3CPX1500A7 - PULSE MODULATOR OR REGULATOR SERVICE

Peak (pulse) plate current capability is dependent on pulse duration (tp) and duty factor (Du).
 Maximum peak plate current for a given value of tp is shown. Maximum Du may then be derived from the relationship: $1.0 = i_b \sqrt{Du}$

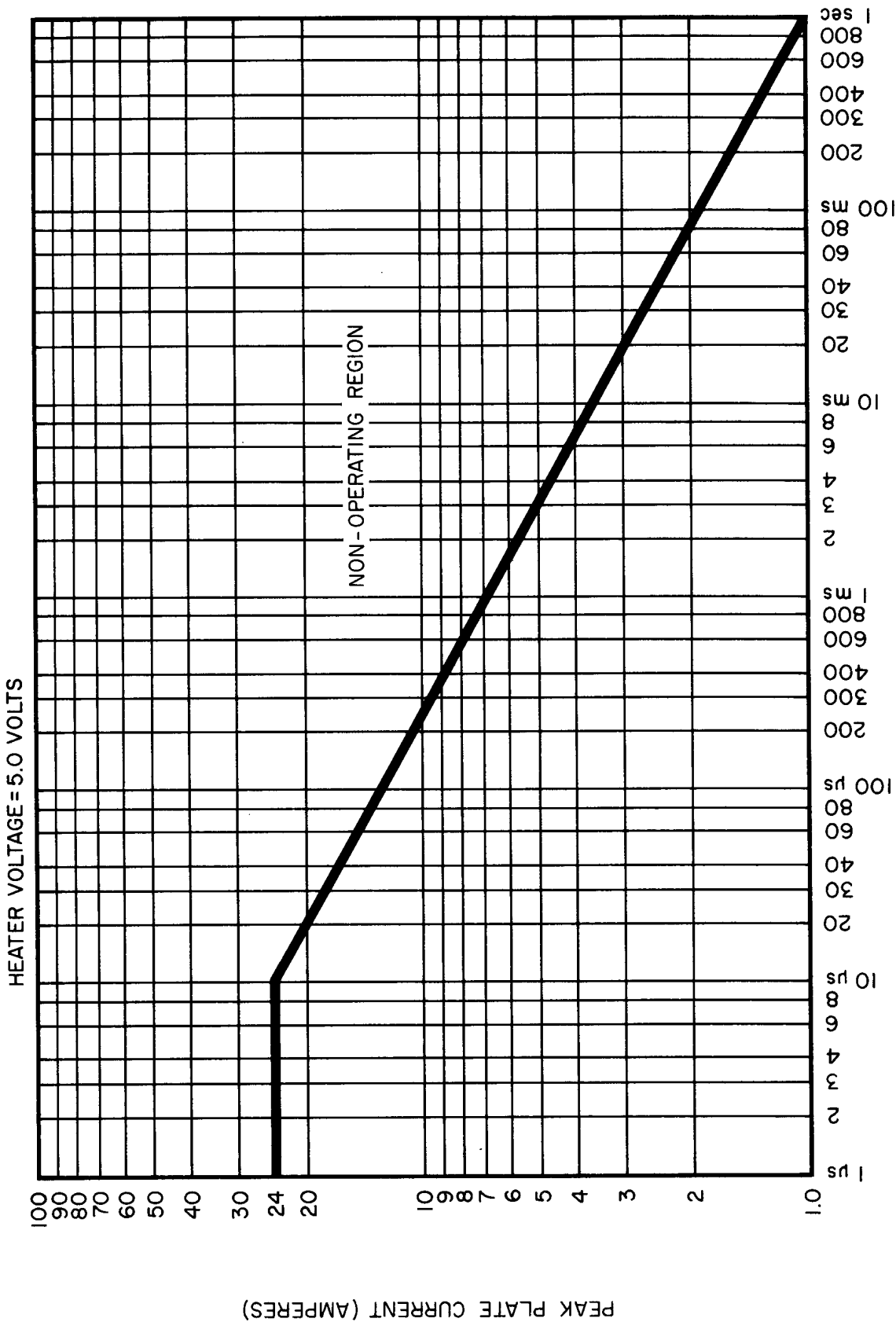

PULSE DURATION (tp)

PULSE DERATING DATA, TYPE 3CPX1500A7 - PULSE MODULATOR OR REGULATOR SERVICE

Peak (pulse) plate current capability is dependent on pulse duration (tp) and duty factor (Du).
 Maximum peak plate current for a given value of tp is shown. Maximum Du may then be derived from the relationship: $1.0 = i_b \sqrt{Du}$



TYPICAL CONSTANT CURRENT CHARACTERISTICS
GROUNDED CATHODE $E_f = 5.5V$
— PLATE CURRENT - AMPERES - - - GRID CURRENT - AMPERES

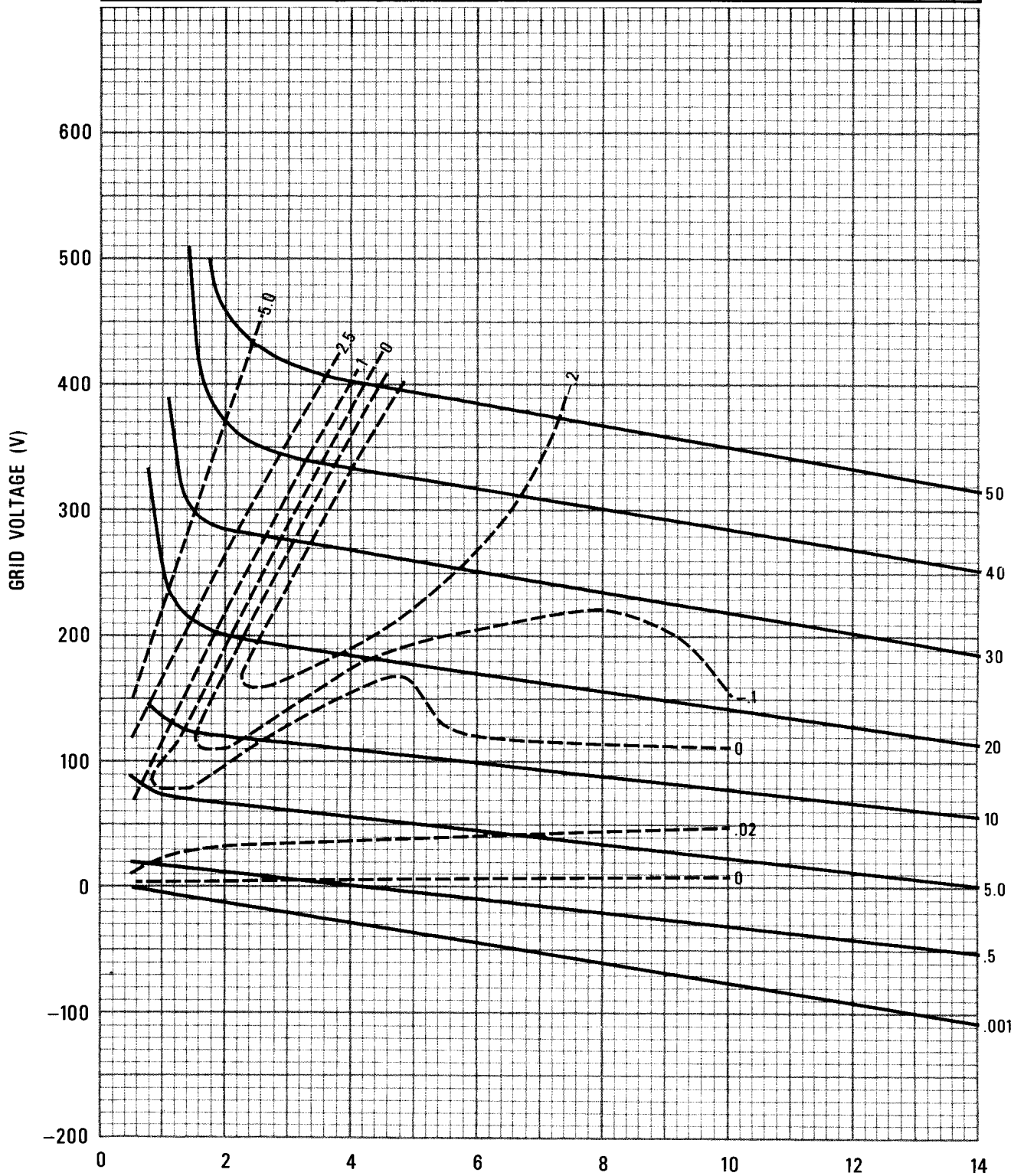

PLATE VOLTAGE (kV)

CURVE #4626



TYPICAL CONSTANT CURRENT CHARACTERISTICS

GROUNDING CATHODE

$E_f = 5.0V$

— PLATE CURRENT — AMPERES

- - - GRID CURRENT — AMPERES

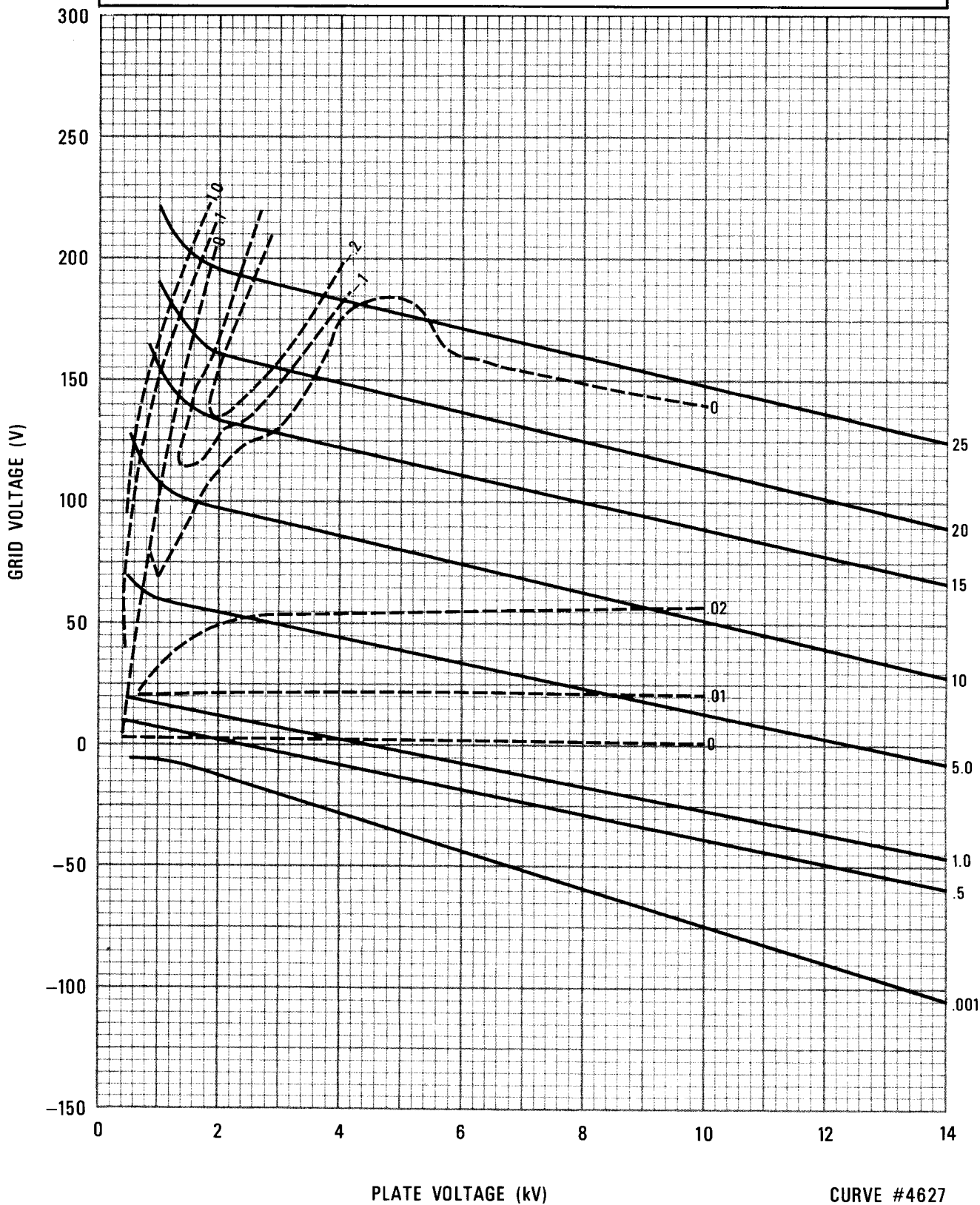



3CPX1500A7

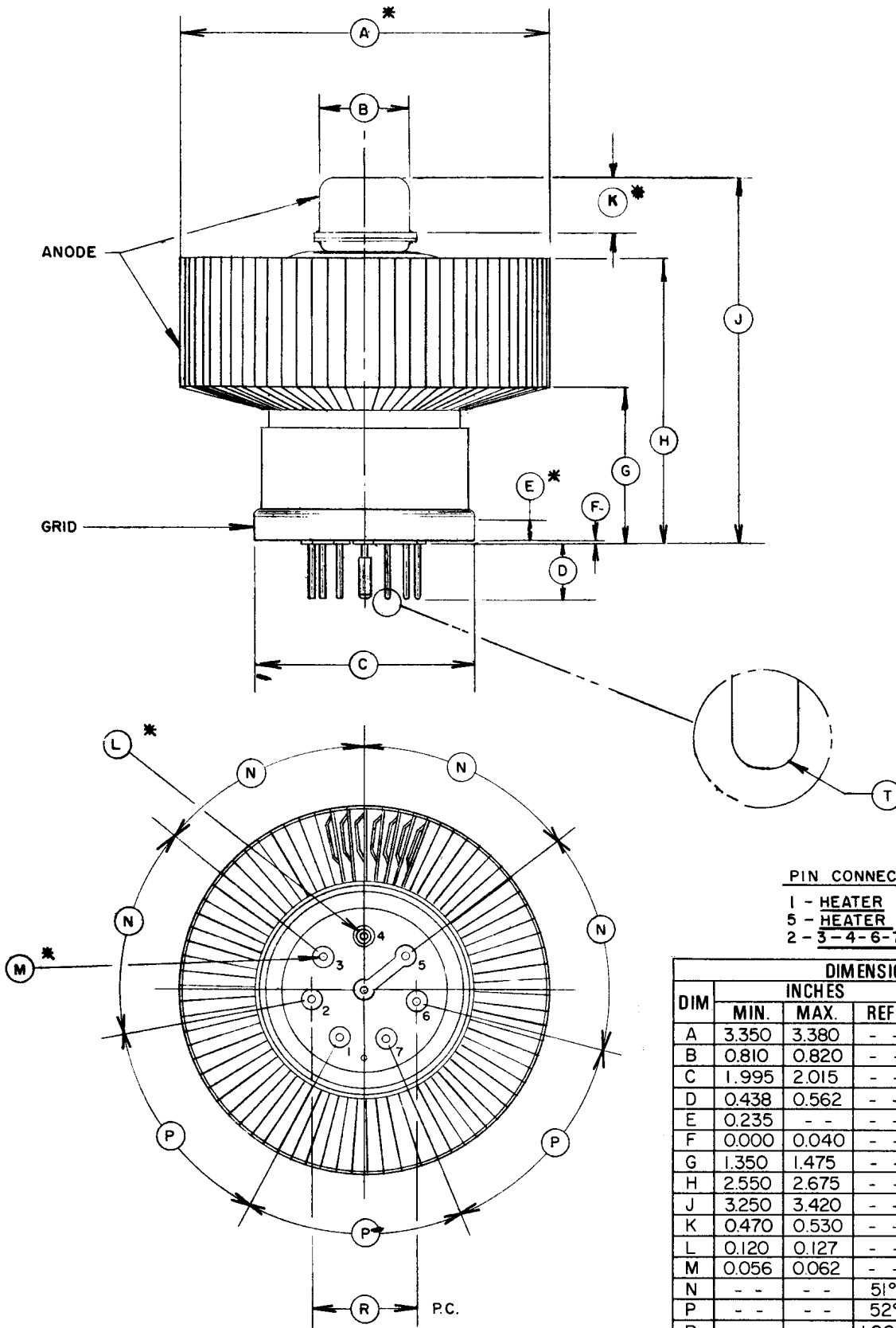

PIN CONNECTIONS

- 1 - HEATER
- 5 - HEATER
- 2 - 3 - 4 - 6 - 7 CATHODE

DIMENSIONAL DATA

DIM	INCHES			MILLIMETERS		
	MIN.	MAX.	REF.	MIN.	MAX.	REF.
A	3.350	3.380	- -	85.09	85.85	- -
B	0.810	0.820	- -	20.57	20.83	- -
C	1.995	2.015	- -	50.67	51.18	- -
D	0.438	0.562	- -	11.13	14.27	- -
E	0.235	- -	- -	5.97	- -	- -
F	0.000	0.040	- -	0.00	1.02	- -
G	1.350	1.475	- -	34.29	37.46	- -
H	2.550	2.675	- -	64.77	67.94	- -
J	3.250	3.420	- -	82.55	86.87	- -
K	0.470	0.530	- -	11.94	13.46	- -
L	0.120	0.127	- -	3.05	3.23	- -
M	0.056	0.062	- -	1.42	1.57	- -
N	- -	- -	51°	- -	- -	51°
P	- -	- -	52°	- -	- -	52°
R	- -	- -	1.000	- -	- -	25.40
T	Q020R	- -	- -	0.51 R	- -	- -

NOTES:

1. REF DIMENSIONS ARE FOR INFO ONLY & ARE NOT REQUIRED FOR INSPECTION PURPOSES.
2. * CONTACT SURFACE
3. DIMENSION T APPLIES TO ALL BUT CENTER PIN.