

SURFACE MOUNT
GLASS PASSIVATED ZENER SILICON RECTIFIER
VOLTAGE RANGE 6.2 TO 91.0 Volts STEADY STATE POWER 1.0 WATT

FEATURES

- * Plastic package has underwriters laboratory
- * Excellent clamping capability
- * Low zener impedance
- * Low regulation factor

MECHANICAL DATA

- * Epoxy : Device has UL flammability classification 94V-0

MAXIMUM RATINGS AND ELECTRICAL CHARACTERISTICS

Ratings at 25 °C ambient temperature unless otherwise specified.

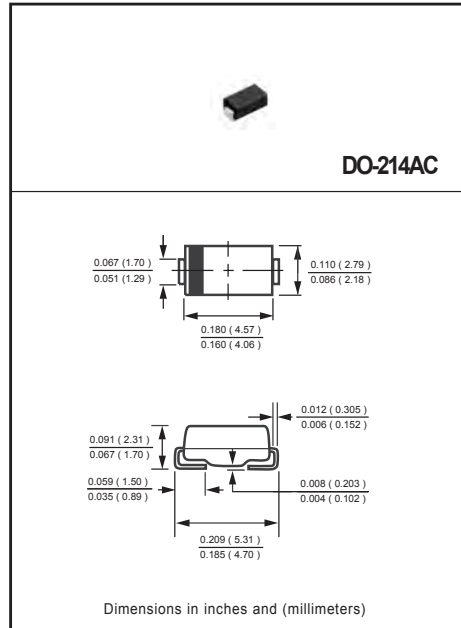

MAXIMUM RATINGS (@ TA = 25°C unless otherwise noted)

CHARACTERISTICS	SYMBOL	Ratings	UNITS
Power Dissipation	PTOT	1	W
Thermal Resis	R _{th} JA	170	K / mW
Tolerance	-	see note1	%
Forward Voltage@If = 100mA	Vf	1.0	V
Junction Temp	T _J	150	°C
Storage Temp	T _{stg}	-55 to 150	°C

ELECTRICAL CHARACTERISTICS (@ TA = 25°C unless otherwise noted)

TYPE	NOMINAL ZENER VOLTAGE			TEST CURRENT (mA)	MAXIMUM DYNAMIC IMPEDANCE			MAXIMUM DC REVERSE LEAKAGE CURRENT		MAXIMUM SURGE CURRENT (NOTE 2) IRM (mApk)	MAXIMUM FORWARD VOLTAGE (Volts)	
	VZ at IZT (NOTE 1) (Volts)				IZT (mA)	ZZT at IZT (ohms)	ZZK at IZK (ohms)	(NOTE 1) IZK (mA)	IR (uA)			VR (Volts)
	Min.	Typ.	Max.									
FM4735W	4.96	6.2	7.34	41.0	2.0	700	1.00	50.0	3.0	730.0	1.2	
FM4735WA	5.58	6.2	6.82	41.0	2.0	700	1.00	50.0	3.0	730.0	1.2	
FM4736W	5.44	6.8	8.16	37.0	3.5	700	1.00	10.0	4.0	660.0	1.2	
FM4736WA	6.12	6.8	7.48	37.0	3.5	700	1.00	10.0	4.0	660.0	1.2	
FM4737W	6.0	7.5	9.0	34.0	4.0	700	0.50	10.0	5.0	605.0	1.2	
FM4737WA	6.75	7.5	8.25	34.0	4.0	700	0.50	10.0	5.0	605.0	1.2	
FM4738W	6.56	8.2	9.84	31.0	4.5	700	0.50	10.0	6.0	550.0	1.2	
FM4738WA	7.38	8.2	9.02	31.0	4.5	700	0.50	10.0	6.0	550.0	1.2	
FM4739W	7.28	9.1	10.92	28.0	5.0	700	0.50	10.0	7.0	500.0	1.2	
FM4739WA	8.19	9.1	10.01	28.0	5.0	700	0.50	10.0	7.0	500.0	1.2	
FM4740W	8.0	10.0	12.0	25.0	7.0	700	0.25	10.0	7.6	454.0	1.2	
FM4740WA	9.0	10.0	11.0	25.0	7.0	700	0.25	10.0	7.6	454.0	1.2	

ELECTRICAL CHARACTERISTICS (At T_A = 25°C unless otherwise noted)

TYPE	NOMINAL ZENER VOLTAGE			TEST CURRENT	MAXIMUM DYNAMIC IMPEDANCE			MAXIMUM DC REVERSE LEAKAGE CURRENT		MAXIMUM SURGE CURRENT	MAXIMUM FORWARD VOLTAGE
	VZ at IZT (NOTE 1) (Volts)			IZT (mA)	ZZT at IZT (ohms)	ZZK at IZK (ohms)	(NOTE 1) IZK (mA)	IR (uA)	VR (Volts)	(NOTE 2) IRM (mApk)	VF at 200mA (Volts)
	Min.	Typ.	Max.								
FM4741W	8.8	11.0	13.2	23.0	8.0	700	0.25	5.0	8.4	414.0	1.2
FM4741WA	9.9	11.0	12.1	23.0	8.0	700	0.25	5.0	8.4	414.0	1.2
FM4742W	9.6	12.0	14.4	21.0	9.0	700	0.25	5.0	9.1	380.0	1.2
FM4742WA	10.8	12.0	13.2	21.0	9.0	700	0.25	5.0	9.1	380.0	1.2
FM4743W	10.4	13.0	15.6	19.0	10.0	700	0.25	5.0	9.9	344.0	1.2
FM4743WA	11.7	13.0	14.3	19.0	10.0	700	0.25	5.0	9.9	344.0	1.2
FM4744W	12.0	15.0	18.0	17.0	14.0	700	0.25	5.0	11.4	305.0	1.2
FM4744WA	13.5	15.0	16.5	17.0	14.0	700	0.25	5.0	11.4	305.0	1.2
FM4745W	12.8	16.0	19.2	15.5	16.0	700	0.25	5.0	12.2	285.0	1.2
FM4745WA	14.4	16.0	17.6	15.5	16.0	700	0.25	5.0	12.2	285.0	1.2
FM4746W	14.4	18.0	21.6	14.0	20.0	750	0.25	5.0	13.7	250.0	1.2
FM4746WA	16.2	18.0	19.8	14.0	20.0	750	0.25	5.0	13.7	250.0	1.2
FM4747W	16.0	20.0	24.0	12.5	22.0	750	0.25	5.0	15.2	225.0	1.2
FM4747WA	18.0	20.0	22.0	12.5	22.0	750	0.25	5.0	15.2	225.0	1.2
FM4748W	17.6	22.0	26.4	11.5	23.0	750	0.25	5.0	16.7	205.0	1.2
FM4748WA	19.8	22.0	24.2	11.5	23.0	750	0.25	5.0	16.7	205.0	1.2
FM4749W	23.2	24.0	28.8	10.5	25.0	750	0.25	5.0	18.2	190.0	1.2
FM4749WA	21.6	24.0	26.4	10.5	25.0	750	0.25	5.0	18.2	190.0	1.2
FM4750W	21.6	27.0	32.4	9.5	35.0	750	0.25	5.0	20.6	170.0	1.2
FM4750WA	24.3	27.0	29.7	9.5	35.0	750	0.25	5.0	20.6	170.0	1.2
FM4751W	24.0	30.0	36.0	8.5	40.0	1000	0.25	5.0	22.8	150.0	1.2
FM4751WA	27.0	30.0	33.0	8.5	40.0	1000	0.25	5.0	22.8	150.0	1.2
FM4752W	26.4	33.0	39.6	7.5	45.0	1000	0.25	5.0	25.1	135.0	1.2
FM4752WA	29.7	33.0	36.3	7.5	45.0	1000	0.25	5.0	25.1	135.0	1.2
FM4753W	28.8	36.0	43.2	7.0	50.0	1000	0.25	5.0	27.4	125.0	1.2
FM4753WA	32.4	36.0	39.6	7.0	50.0	1000	0.25	5.0	27.4	125.0	1.2
FM4754W	31.2	39.0	46.8	6.5	60.0	1000	0.25	5.0	29.7	115.0	1.2
FM4754WA	35.1	39.0	42.9	6.5	60.0	1000	0.25	5.0	29.7	115.0	1.2
FM4755W	34.4	43.0	51.6	6.0	70.0	1500	0.25	5.0	32.7	110.0	1.2
FM4755WA	38.7	43.0	47.3	6.0	70.0	1500	0.25	5.0	32.7	110.0	1.2
FM4756W	37.6	47.0	56.4	5.5	80.0	1500	0.25	5.0	35.8	95.0	1.2
FM4756WA	42.3	47.0	51.7	5.5	80.0	1500	0.25	5.0	35.8	95.0	1.2
FM4757W	40.8	51.0	61.2	5.0	95.0	1500	0.25	5.0	38.8	90.0	1.2
FM4757WA	45.9	51.0	56.1	5.0	95.0	1500	0.25	5.0	38.8	90.0	1.2
FM4758W	44.8	56.0	67.2	4.5	110.0	2000	0.25	5.0	42.6	80.0	1.2
FM4758WA	50.4	56.0	61.6	4.5	110.0	2000	0.25	5.0	42.6	80.0	1.2
FM4759W	49.6	62.0	74.4	4.0	125.0	2000	0.25	5.0	47.1	70.0	1.2
FM4759WA	55.8	62.0	68.2	4.0	125.0	2000	0.25	5.0	47.1	70.0	1.2

ELECTRICAL CHARACTERISTICS (At $T_A = 25^\circ\text{C}$ unless otherwise noted)

TYPE	NOMINAL ZENER VOLTAGE			TEST CURRENT	MAXIMUM DYNAMIC IMPEDANCE			MAXIMUM DC REVERSE LEAKAGE CURRENT		MAXIMUM SURGE CURRENT	MAXIMUM FORWARD VOLTAGE
	VZ at IZT (NOTE 1) (Volts)				IZT (mA)	ZZT at IZT (ohms)	ZZK at IZK (ohms)	(NOTE 1) IZK (mA)	IR (μA)		
	Min.	Typ.	Max.								
FM4760W	54.4	68.0	81.6	3.7	150.0	2000	0.25	5.0	51.7	65.0	1.2
FM4760WA	61.2	68.0	74.8	3.7	150.0	2000	0.25	5.0	51.7	65.0	1.2
FM4761W	60.0	75.0	90.0	3.3	175.0	2000	0.25	5.0	56.0	60.0	1.2
FM4761WA	67.5	75.0	82.5	3.3	175.0	2000	0.25	5.0	56.0	60.0	1.2
FM4762W	65.6	82.0	98.4	3.0	200.0	3000	0.25	5.0	62.2	55.0	1.2
FM4762WA	73.8	82.0	90.2	3.0	200.0	3000	0.25	5.0	62.2	55.0	1.2
FM4763W	72.8	91.0	109.2	2.0	250.0	3000	0.25	5.0	69.2	50.0	1.2
FM4763WA	81.9	91.0	100.1	2.0	250.0	3000	0.25	5.0	69.2	50.0	1.2

Notes : 1. Standard V_Z Tolerance is 20% , Suffix " A " denotes 10% tolerance.

2. Surge current is a non-repetitive, 8.3ms pulse width square wave or equivalent sine-wave superimposed on IZT per JEDEC Method.

3. Maximum steady state power dissipation is 1.0 watt at $T_L = 75^\circ\text{C}$.

4. "Fully ROHS compliant", "100% Sn plating (Pb-free)".

2007-12

RATING AND CHARACTERISTICS CURVES (FM4735W(A) THRU FM4763W(A))

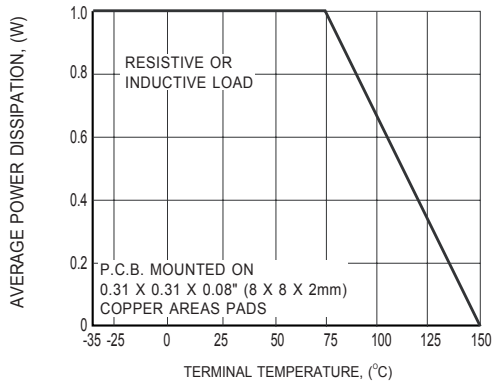

FIG.1 MAXIMUM CONTINUOUS POWER DISSIPATION

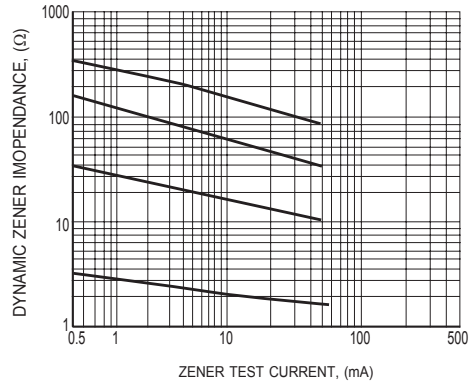

FIG.2 TYPICAL ZENER IMPEDANCE

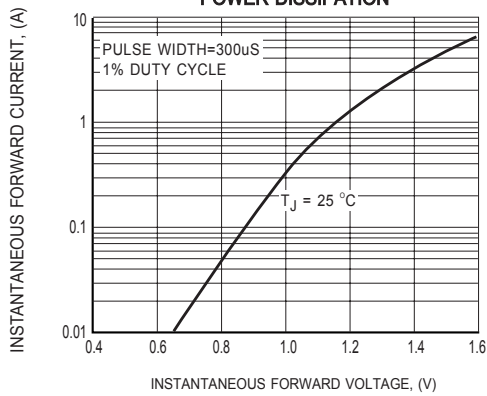

FIG.3 TYPICAL INSTANTANEOUS FORWARD CHARACTERISTICS FOR FM4763W

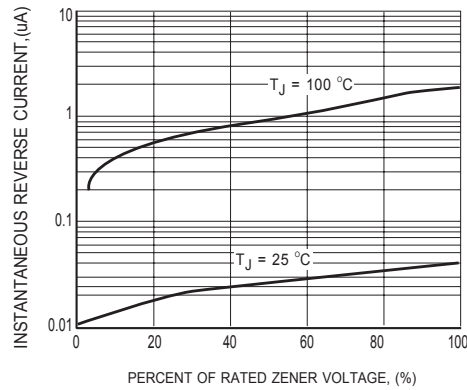

FIG.4 TYPICAL REVERSE CHARACTERISTICS

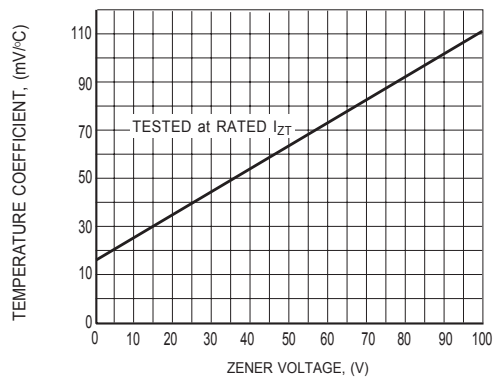

FIG.5 TYPICAL TEMPERATURE COEFFICIENTS



DISCLAIMER NOTICE

Rectron Inc reserves the right to make changes without notice to any product specification herein, to make corrections, modifications, enhancements or other changes. Rectron Inc or anyone on its behalf assumes no responsibility or liability for any errors or inaccuracies. Data sheet specifications and its information contained are intended to provide a product description only. "Typical" parameters which may be included on RECTRON data sheets and/ or specifications can and do vary in different applications and actual performance may vary over time. Rectron Inc does not assume any liability arising out of the application or use of any product or circuit.

Rectron products are not designed, intended or authorized for use in medical, life-saving implant or other applications intended for life-sustaining or other related applications where a failure or malfunction of component or circuitry may directly or indirectly cause injury or threaten a life without expressed written approval of Rectron Inc. Customers using or selling Rectron components for use in such applications do so at their own risk and shall agree to fully indemnify Rectron Inc and its subsidiaries harmless against all claims, damages and expenditures.

