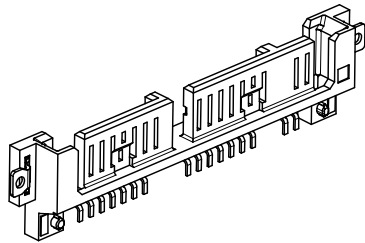
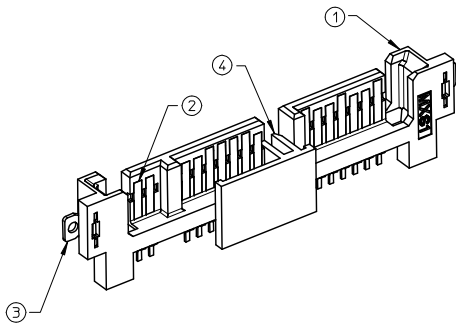

TABLE 2: PART NUMBER

PART NUMBER	CAP	PACKAGING
78285-0001	NO	TRAY
78285-0021	YES	TAPE & REEL



NO.	PART NAME	QTY.	MATERIAL
1	HOUSING	1	LIQUID CRYSTAL POLYMER (LCP), GLASS FILLED, UL 94V-0, COLOUR: BLACK.
2	TERMINAL	16	COPPER ALLOY
3	SOLDER TAB	2	COPPER ALLOY
4	CAP	1	NYLON 46, GLASS FILLED, COLOUR: BLACK.

NOTES:

1. MATERIAL: REFER TO THE ABOVE PART LIST
2. PLATING SPECIFICATION: REFER TO TABLE 1
3. PRODUCT SPECIFICATION: PS-78285-002
4. PACKAGING SPECIFICATION: REFER TO TABLE 2
5. PRODUCT CONFORMS TO SERIAL ATA SPECIFICATION
6. PRODUCT IS COMPLIANT TO RoHS DIRECTIVE WITH THE FOLLOWING BANNED SUBSTANCES - LEAD, MERCURY, CADMIUM, HEXAVALENT CHROMIUM, POLYBROMINATED BIPHENYLS AND POLYBROMINATED DIPHENYLS ETHERS
7. NON FUNCTIONAL CORING MAY VARY FROM DRAWING

TABLE 1: PLATING SPECIFICATION

PART NAME	MATING AREA	SOLDER TAIL AREA	OTHER AREAS
TERMINAL	GOLD (0.76um MIN.)	GOLD FLASH (0.05um MIN.)	NICKEL PLATING
	OVER NICKEL (1.27um MIN.) UNDERPLATE		
SOLDER TAB	TIN (2.54um MIN.) OVER NICKEL (1.27um MIN.) UNDERPLATE		NICKEL PLATING

ADD GATE LOCATION EIC NO: S2009-0894 DRWN: XYONG CHYKHLIM APPR: BOXOK 2009/06/01 2009/06/02	DESCRIPTION REV A	QUALITY SYMBOLS ▽=0 ▽=0	GENERAL TOLERANCES (UNLESS SPECIFIED) mm INCH 4 PLACES ± --- ± --- 3 PLACES ± --- ± --- 2 PLACES ± 0.20 ± --- 1 PLACE ± --- ± --- ANGULAR ± 3°	DIMENSION STYLE MM ONLY DRAWN BY: YKOH DATE: 2007/04/26 CHECKED BY: CGTAN DATE: 2007/06/05 APPROVED BY: KCLING DATE: 2007/06/05	SCALE: NTS DESIGN UNITS: METRIC THIRD ANGLE PROJECTION	TITLE: SERIAL ATA PLUG RIGHT ANGLE SMT FOR 1.8 INCH SSD MOLEX INCORPORATED DOCUMENT NO. SD-78285-001 SHEET NO. 1 OF 5	
		DRAFT WHERE APPLICABLE MUST REMAIN WITHIN DIMENSIONS			MATERIAL NO. SEE TABLE	THIS DRAWING CONTAINS INFORMATION THAT IS PROPRIETARY TO MOLEX INCORPORATED AND SHOULD NOT BE USED WITHOUT WRITTEN PERMISSION	
					SIZE: A3		

10 9 8 7 6 5 4 3 2 1

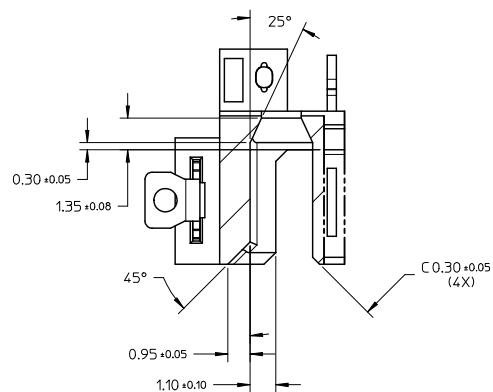
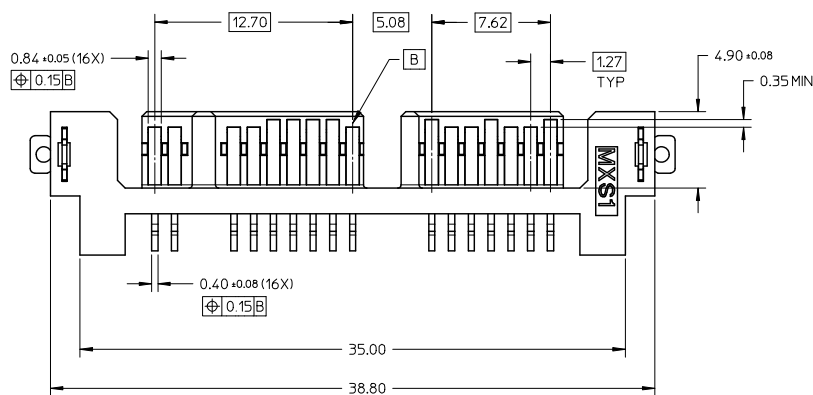
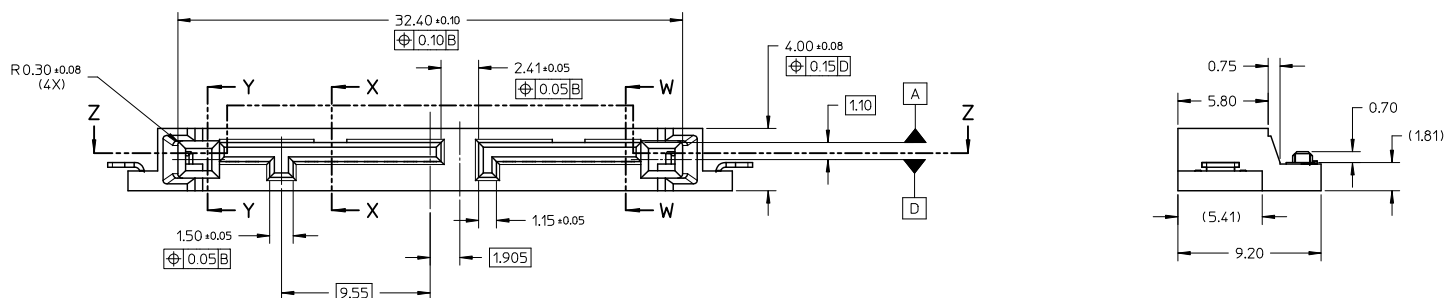

PARTIAL1
OF SECTION Z-Z

ADD GATE LOCATION IEC NO: S22009-0894 DRWN: NYONG CHK: KHLIM APPR: BOXOK 2009/06/01 2009/06/01 2009/06/02	QUALITY SYMBOLS 	GENERAL TOLERANCES (UNLESS SPECIFIED)		DIMENSION STYLE		SCALE	DESIGN UNITS	THIRD ANGLE PROJECTION			
				MM ONLY		NTS	METRIC				
				DRAWN BY		DATE		TITLE			
				YKOH		2007/04/26		SERIAL ATA PLUG RIGHT ANGLE SMT FOR 1.8 INCH SSD			
		3 PLACES ± --- ± ---		CHECKED BY		DATE		MOLEX INCORPORATED DOCUMENT NO. SD-78285-001 SHEET NO. 2 OF 5			
		2 PLACES ± 0.20 ± --- ± ---		CGTAN		2007/06/05					
		1 PLACE ± --- ± ---		APPROVED BY		DATE					
		ANGULAR ± 3°		KCLING		2007/06/05					
		DRAFT WHERE APPLICABLE MUST REMAIN WITHIN DIMENSIONS		MATERIAL NO.		SEE TABLE					
				SIZE		A 3		THIS DRAWING CONTAINS INFORMATION THAT IS PROPRIETARY TO MOLEX INCORPORATED AND SHOULD NOT BE USED WITHOUT WRITTEN PERMISSION			

9 8 7 6 5 4 3 2 1

10 9 8 7 6 5 4 3 2 1

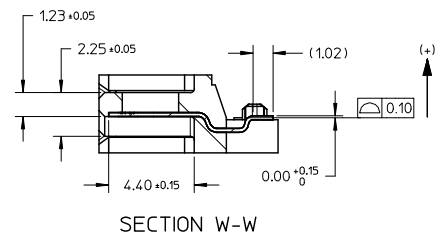
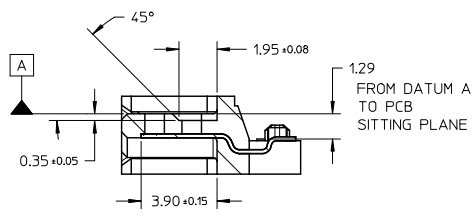
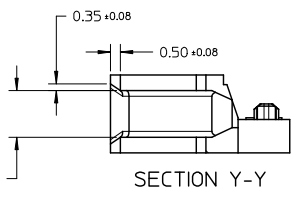
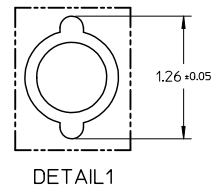
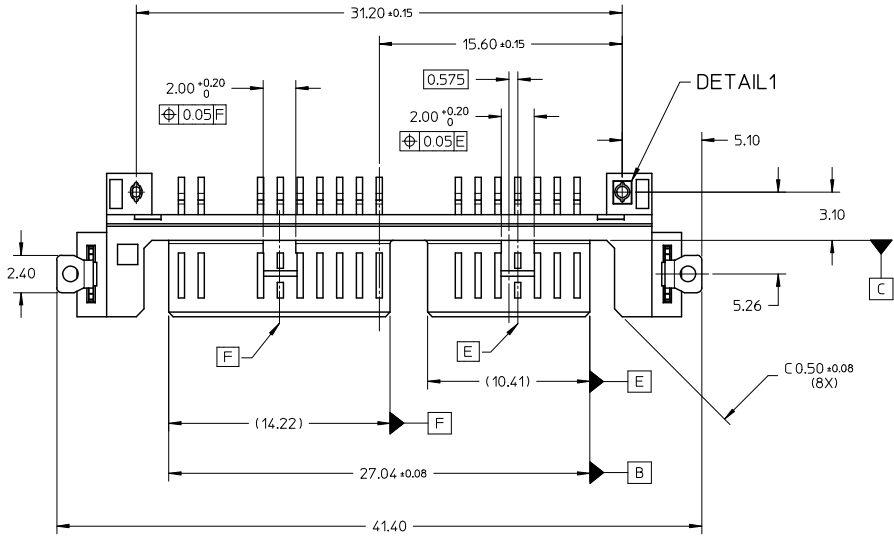

ADD GATE LOCATION E.C. NO.: S22009-0894 DRWN.: KYONG CHKD.: HILIM APPR.: BOXOK 2009/06/01 2009/06/01 2009/06/02	QUALITY SYMBOLS ▽=0 ▽=0	GENERAL TOLERANCES (UNLESS SPECIFIED)		DIMENSION STYLE MM ONLY	SCALE NTS	DESIGN UNITS METRIC	THIRD ANGLE PROJECTION	
		4 PLACES ± --- ± ---	mm INCH	DRAWN BY YKOH	DATE 2007/04/26	TITLE SERIAL ATA PLUG RIGHT ANGLE SMT FOR 1.8 INCH SSD		
		3 PLACES ± --- ± ---		CHECKED BY CGTAN	DATE 2007/06/05	MOLEX INCORPORATED		
		2 PLACES ± 0.20 ± ---		APPROVED BY KCLING	DATE 2007/06/05	DOCUMENT NO. SD-78285-001	SHEET NO. 3 OF 5	
		1 PLACE ± --- ± ---		MATERIAL NO. SEE TABLE	THIS DRAWING CONTAINS INFORMATION THAT IS PROPRIETARY TO MOLEX INCORPORATED AND SHOULD NOT BE USED WITHOUT WRITTEN PERMISSION			
DRAFT WHERE APPLICABLE MUST REMAIN WITHIN DIMENSIONS								

tb_frame_A3_P_AM.T
Rev. E 2006/04/15

9 8 7 6 5 4 3 2 1

10 9 8 7 6 5 4 3 2 1

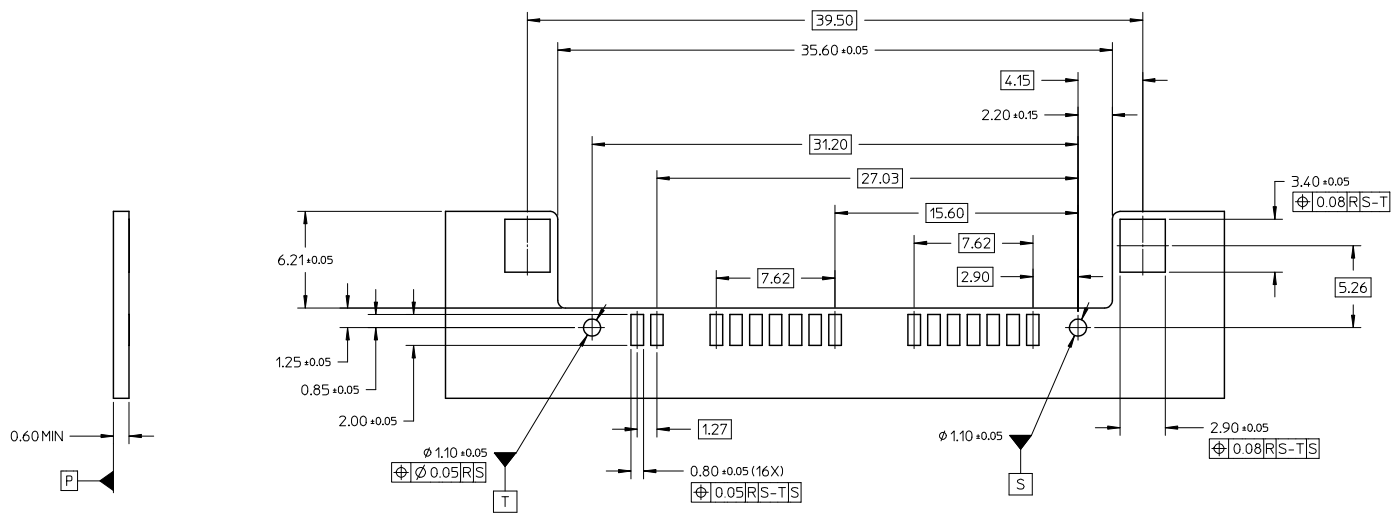

RECOMMENDED PCB LAYOUT

ADD GATE LOCATION E.C. NO: S2009-0894 DRAWN: NYONG CHYKHLIM APPR: BOBOK 2009/06/01 2009/06/02	QUALITY SYMBOLS ▽=0 ▽=0	GENERAL TOLERANCES (UNLESS SPECIFIED)		DIMENSION STYLE MM ONLY		SCALE NTS	DESIGN UNITS METRIC	THIRD ANGLE PROJECTION		
		4 PLACES ± --- ± ---	mm INCH	DRAWN BY YKOH	DATE 2007/04/26	TITLE SERIAL ATA PLUG RIGHT ANGLE SMT FOR 1.8 INCH SSD				
		3 PLACES ± --- ± ---	2 PLACES ± 0.20 ± ---	CHECKED BY CGTAN	DATE 2007/06/05	MOLEX INCORPORATED				
		1 PLACE ± --- ± ---	ANGULAR ± 3°	APPROVED BY KCLING	DATE 2007/06/05	MATERIAL NO. SEE TABLE	DOCUMENT NO. SD-78285-001	SHEET NO. 4 OF 5		
DRAFT WHERE APPLICABLE MUST REMAIN WITHIN DIMENSIONS		THIS DRAWING CONTAINS INFORMATION THAT IS PROPRIETARY TO MOLEX INCORPORATED AND SHOULD NOT BE USED WITHOUT WRITTEN PERMISSION								

9 8 7 6 5 4 3 2 1

10 9 8 7 6 5 4 3 2 1

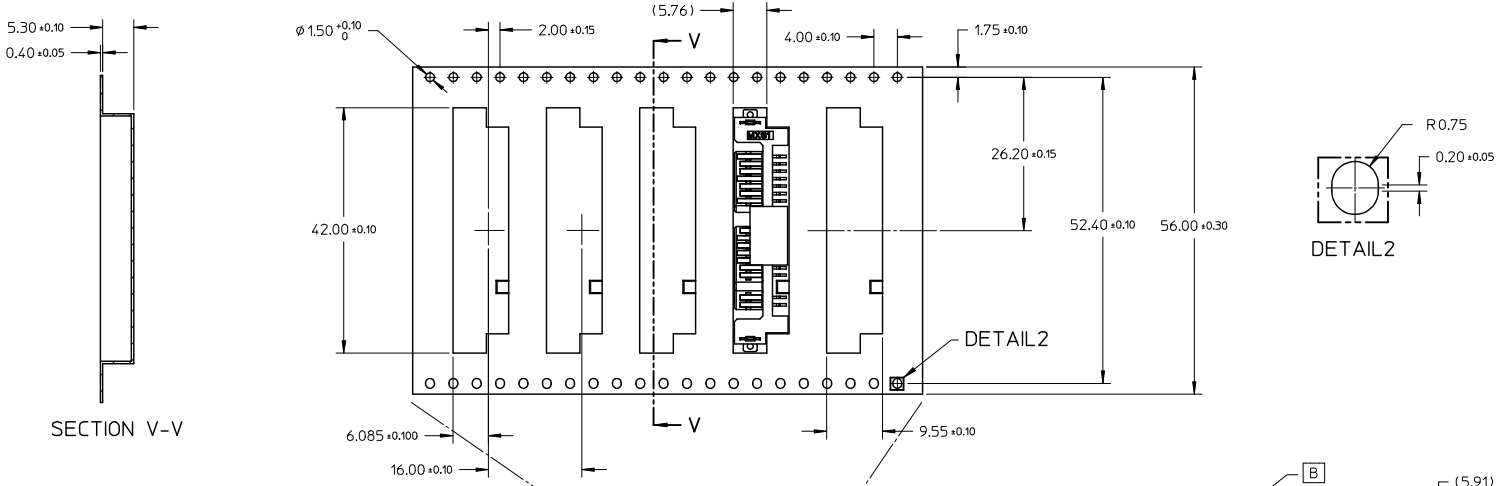

SECTION V-V

DETAIL 2

NOTES:

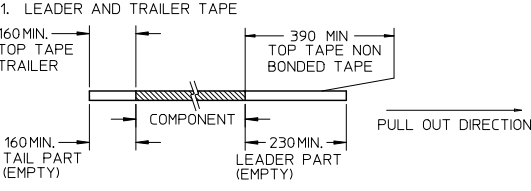

1. LEADER AND TRAILER TAPE
 2. PEELING OFF FORCE OF THE TOP TAPE: 20 - 80gf.
 (PEELING DIRECTION AS SHOWN IN FOLLOWING FIGURE)

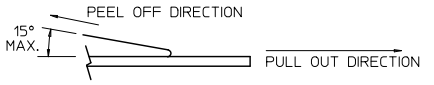

3. TAPE AND REEL SPECIFICATION IS AS PER EIA-481.
 4. TAPE AND REEL QUANTITY : 750 PCS/ REEL.
 5. THE TAPE IS TREATED FOR ANTI-STATIC.

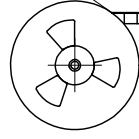

PULL OUT DIRECTION

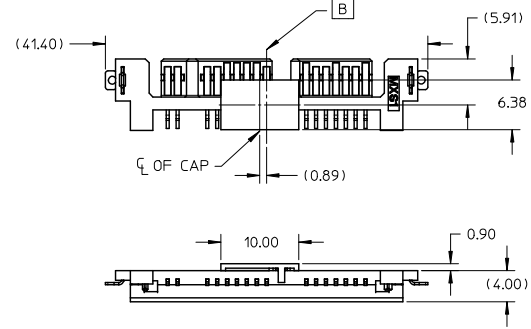

ADD GATE LOCATION EC NO: S2009-0894 DRWN: KYONG CHKD: HILIM APPR: BOXOK	DESCRIPTION REV	QUALITY SYMBOLS ▽=0 ▽=0	GENERAL TOLERANCES (UNLESS SPECIFIED)		DIMENSION STYLE MM ONLY		SCALE NTS	DESIGN UNITS METRIC	THIRD ANGLE PROJECTION
			4 PLACES ± --- ± ---	3 PLACES ± --- ± ---	2 PLACES ± 0.20 ± ---	1 PLACE ± --- ± ---	ANGULAR ± 3 °	DRAWN BY YKOH	DATE 2007/04/26
DRAFT WHERE APPLICABLE MUST REMAIN WITHIN DIMENSIONS			SEE TABLE		APPROVED BY KCLING		DATE 2007/06/05	MATERIAL NO. DOCUMENT NO. SD-78285-001	
			SIZE A3		THIS DRAWING CONTAINS INFORMATION THAT IS PROPRIETARY TO MOLEX INCORPORATED AND SHOULD NOT BE USED WITHOUT WRITTEN PERMISSION				

9 8 7 6 5 4 3 2 1