

Ceramic Resonators, Chip Type (2 Array Type)

- Type: **EFOP**
- Type: **EFOD**
- Type: **EFOPS**
- Type: **EFOPM**
- Type: **EFODM**
- Type: **EFOLM**

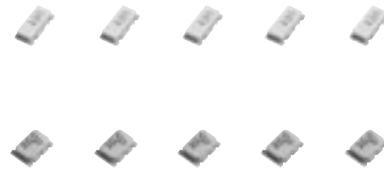

■ Features

- Encased in a ceramic package
- High reliability against soldering heat and mechanical stress
- Moisture-proof sealing
- 1.2 mm maximum in thickness (PS/PM/DM/LM)
- Designed for reflow soldering
- Flat-bottom plate for better mounting
- RoHS compliant

■ Recommended Applications

- Clock generator for microprocessors
- Carrier circuit between telecommunication equipment (Telephone to telephone, personal computer to printer)

■ Handling Precautions (See Page 175 to 176)

■ Packaging Specifications

See Page 174, 177

■ Explanation of Part Numbers

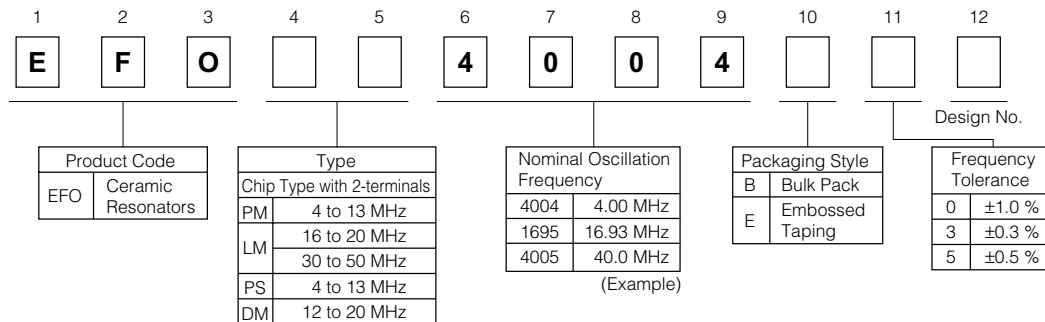
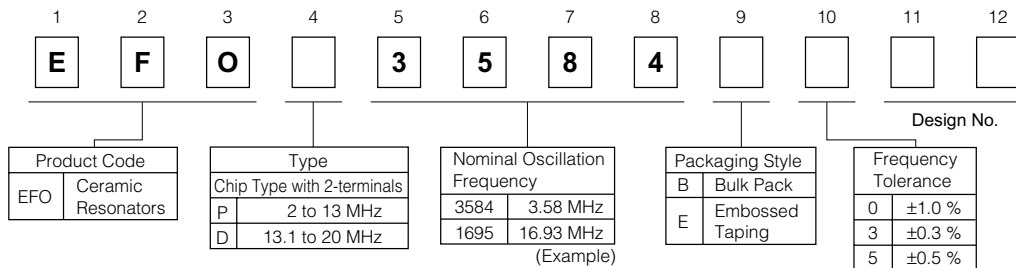

Part Number	Frequency range (MHz)	Frequency Temperature Characteristics (-20 to +80 °C)	Attached Capacitors (Reference)
EFOP	2.00 to 8.39	±0.3 %	33 pF
	8.40 to 13.0	±1.0 %	
EFOD	13.1 to 20.0	±1.0 %	33 pF
EFOPS	4.00 to 8.39	±0.6 %	21 pF
	8.40 to 13.0	±1.0 %	
EFOPM	4.00 to 8.39	±0.3 %	33 pF
	8.40 to 13.0	±1.0 %	
EFODM	12.0 to 20.0	±1.0 %	18 pF
EFOLM	16.0 to 20.0	±1.0 %	10 pF
	30.0 to 50.0	±0.3 %	

Design and specifications are each subject to change without notice. Ask factory for the current technical specifications before purchase and/or use. Should a safety concern arise regarding this product, please be sure to contact us immediately.

00 Sep. 2008

■ Dimensions in mm (not to scale)
 Recommended Land Dimensions
 [Type EFOP].....2.0 to 13.0 MHz

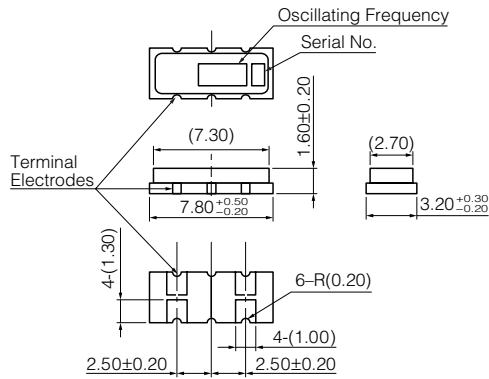

[Type EFOP, EFOPM]

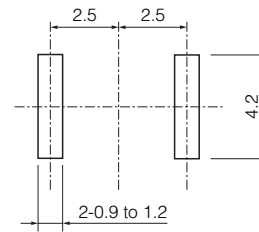

[Type EFOPM].....4.0 to 13.0 MHz

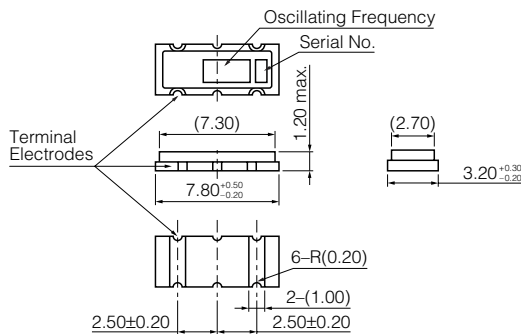

[Type EFOPS].....4.0 to 13.0 MHz

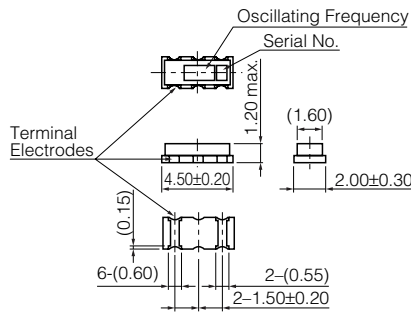

[Type EFOPS]

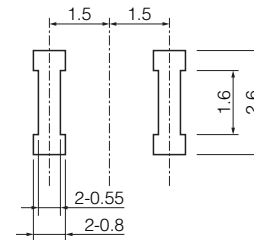

[Type EFOD].....13.1 to 20.0 MHz

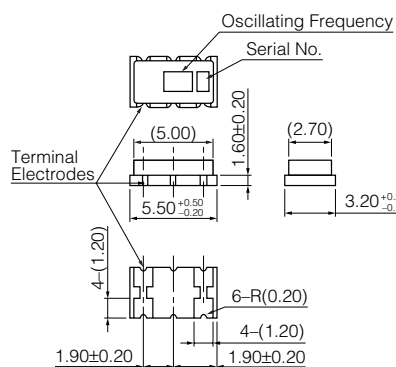

[Type EFOD]

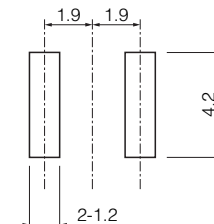

Design and specifications are each subject to change without notice. Ask factory for the current technical specifications before purchase and/or use.
 Should a safety concern arise regarding this product, please be sure to contact us immediately.

00 Sep. 2008

■ Dimensions in mm (not to scale)
 Recommended Land Dimensions
 [Type EFODM].....12.0 to 20.0MHz

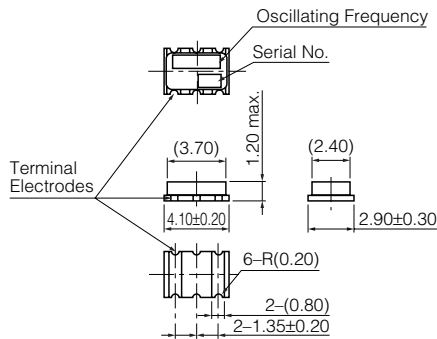

[Type EFODM]

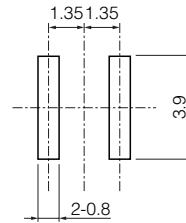

[Type EFOLM].....16.0 to 20.0, 30.0 to 50.0 MHz

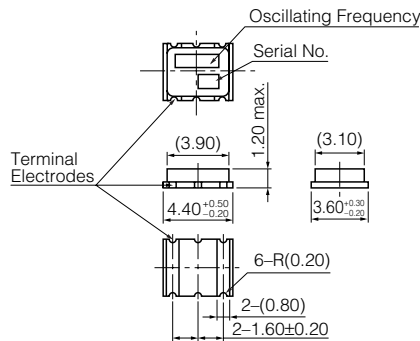

[Type EFOLM]

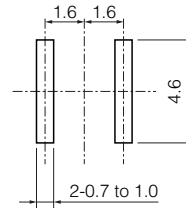

■ Test Circuits Diagram

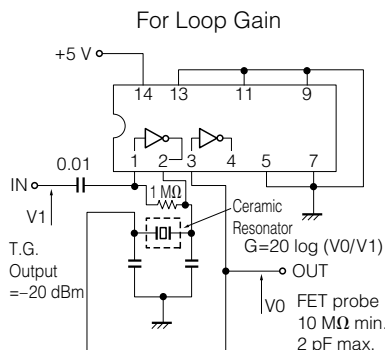
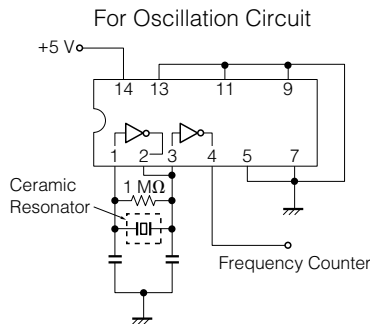

Frequency	IC
2.00 to 8.39 MHz	μPD4069UBC, TC4069UBP or similar
8.40 to 50.0 MHz	μPD74HCU, TC74HCU04AP or similar

■ Typical Characteristics Temperature Characteristics

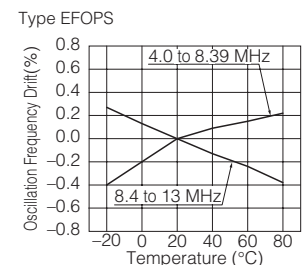
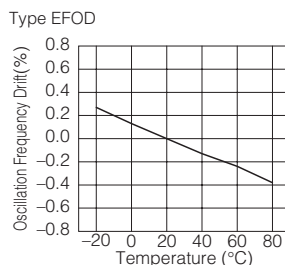
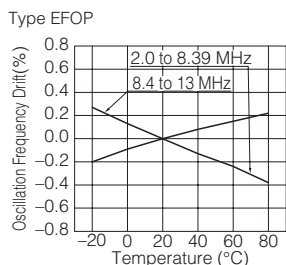

Design and specifications are each subject to change without notice. Ask factory for the current technical specifications before purchase and/or use.
 Should a safety concern arise regarding this product, please be sure to contact us immediately.

00 Sep. 2008

Typical Characteristics Temperature Characteristics

Type EFOPM

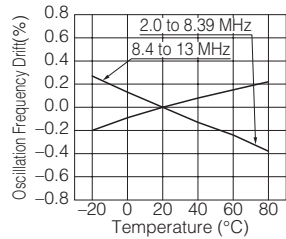

Type EFODM

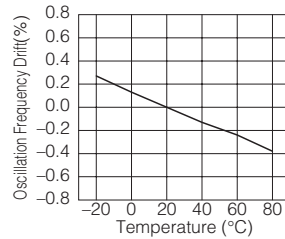

Type EFOLM

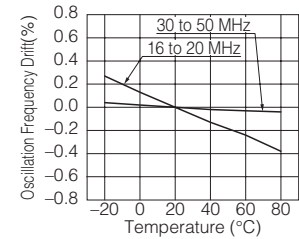

Packaging Specifications

Supplied in bulk or taped & reel packing style

Standard Packing Quantity

Type	Embossed Taping	Bulk
EFOP, EFOPM	2500 pcs./reel	500 pcs./bag
EFOPS	2000 pcs./reel	
EFOD, EFODM, EFOLM	1000 pcs./reel	

Dimensions for Reel in mm (not to scale)

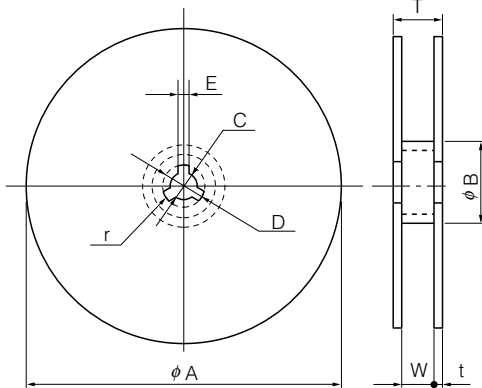

[Type EFOP, EFOPM]

Dim. (mm)	φA	φB	C	D	E
	330±5	80 min.	13.0±0.5	21.0±0.8	2.0±0.5
Dim. (mm)	W	T	t	r	
	16.4 ^{+2.0} ₀	22.4 max.	3 max.	1.0	

[Type EFOPS, EFOD, EDODM, EFOLM]

Dim. (mm)	φA	φB	C	D	E
	180±5	60 min.	13.0±0.5	21.0±0.8	2.0±0.5
Dim. (mm)	W	T	t	r	
	12.4 ^{+2.0} ₀	18.4 max.	3 max.	1.0	

Embossed Taping

[Type EFOP, EFOPM]

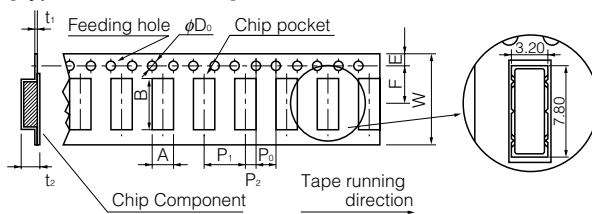

Dim. (mm)	A	B	W	F	E	P ₁
	3.7±0.2	8.3±0.2	16.0±0.3	7.5±0.1	1.75±0.10	8.0±0.1
Dim. (mm)	P ₂	P ₀	φD ₀	t ₁	t ₂	
	2.0±0.1	4.0±0.1	1.5 ^{+0.1} ₀	0.3	3.5 max.	

[Type EFOPS]

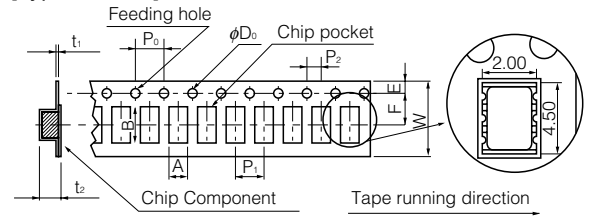

Dim. (mm)	A	B	W	F	E	P ₁
	2.6±0.2	5.1±0.2	12.0±0.3	5.5±0.1	1.75±0.10	4.0±0.1
Dim. (mm)	P ₂	P ₀	φD ₀	t ₁	t ₂	
	2.0±0.1	4.0±0.1	1.5 ^{+0.1} ₀	0.6 max.	3.0 max.	

[Type EFOD, EFODM, EFOLM]

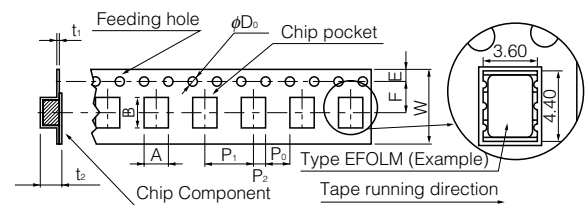

Dim. (mm)	A	B	W	F	E	P ₁
	①	②	12.0±0.3	5.5±0.1	1.75±0.10	8.0±0.1
Dim. (mm)	P ₂	P ₀	φD ₀	t ₁	t ₂	
	2.0±0.1	4.0±0.1	1.5 ^{+0.1} ₀	0.6 max.	3.0 max.	

Dim. (mm)	A	B
	①	②
Type EFOD	3.7±0.2	6.0±0.2
Type EFODM	3.4±0.2	4.6±0.2
Type EFOLM	4.1±0.2	4.9±0.2

Design and specifications are each subject to change without notice. Ask factory for the current technical specifications before purchase and/or use. Should a safety concern arise regarding this product, please be sure to contact us immediately.