

# KBR -M, -MS, -MSA, -MSB Series Ceramic Resonators

## MHz Band Ceramic Resonators

$f_o$ : 2.00 to 13.00 MHz

### FEATURES

- 1) Ultracompact, lightweight design
- 2) Resistant to damage from impact and vibration
- 3) Excellent temperature stability ( $\pm 0.3\%$ )
- 4) Low cost
- 5) Bulk packaged 500 pieces per bag or 2000 pieces per reel
- 6) Sold in increments of 200 pieces

### HOW TO ORDER

#### KBR - 4.00 MSA TR

- ①      ②      ③      ④
- ① Type: (Kyocera Bulk Resonator)
  - ② Oscillation frequency (MHz)
  - ③ Resonator type:  
 MS = 2.00 to 3.57 MHz  
 MSA = 3.58 to 8.00 MHz (Water resistant)  
 MSB = 3.58 to 6.00 MHz ("No-Clean" Process only)  
 M = 6.01 to 13.00 MHz
  - ④ Packaging:  
 TR = Tape and reel  
 □ = Bulk



### SPECIFICATIONS (KBR-□MS/KBR-□MSA/KBR-□MSB/KBR-□M Series)

Series	MS	MSA, -MSB	M	M
Dimension	Fig. A	Fig. B	Fig. C	Fig. D
Oscillation Frequency	2.00 to 3.57 MHz	3.58 to 8.00 MHz	6.01 to 6.99 MHz	7.00 to 13.00 MHz
Frequency Tolerance	$\pm 0.5\%$	$\pm 0.5\%$	$\pm 0.5\%$	$\pm 0.5\%$
Resonant Impedance	100 Max	30 Max	40 Max	40 Max
Temperature Characteristic (-20 to +80°C)	$\pm 0.3\%$	$\pm 0.3\%$	$\pm 0.5\%$	$\pm 0.5\%$

### DIMENSIONS

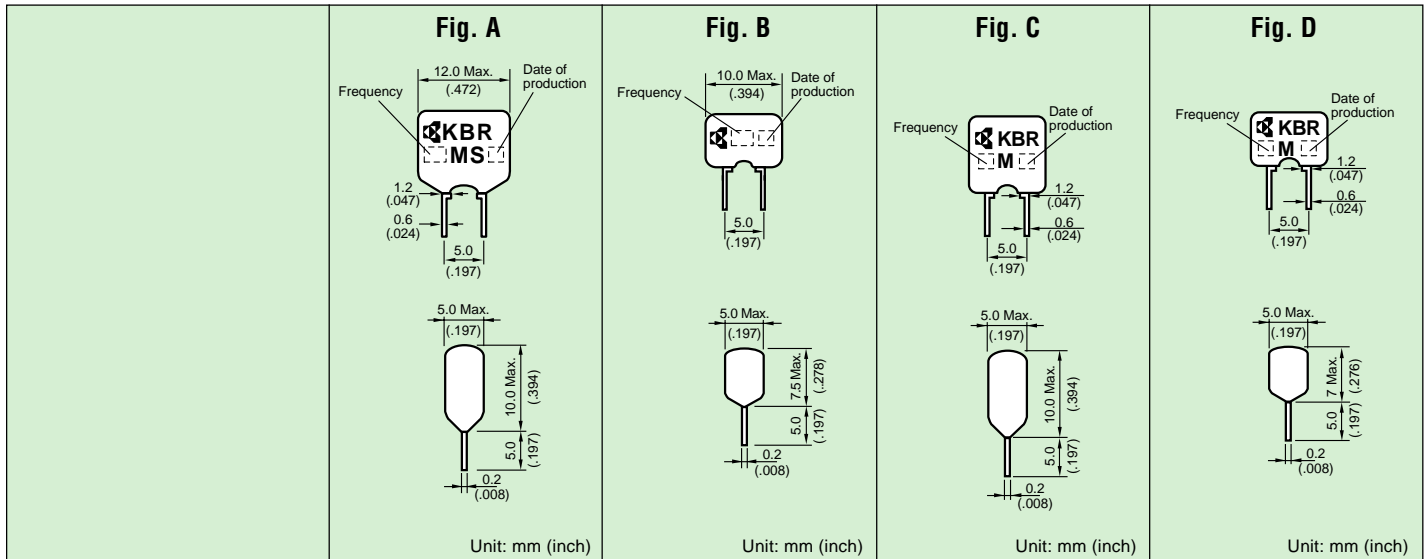

### KBR-3.58MSA - 200 series for Telephone D.T.M.F. Applications

P/N	Frequency	Frequency Tolerance	Resonant Resistance	Temperature Stability (-20 to +80°C)	Dimensions
KBR-3.58MSA-201	3.5795MHz	+0 -0.25%	30 Max	$\pm 0.3\%$	Fig. B
KBR-3.58MSA-202		+0.15 -0.10%			
KBR-3.58MSA-203		+0.30 -0.05%			
KBR-3.58MSA-204		+0.45 +0.20%			
KBR-3.58MSA-205		+0.60 +0.35%			
KBR-3.58MSA-206		-0.30 -0.55%			
KBR-3.58MSA-207		-0.15 -0.40%			

### TEST CIRCUIT

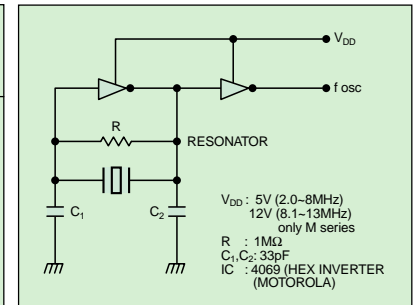

# KBR -MY Series Ceramic Resonators

High Frequency MHz Band Ceramic Resonators  $f_o$ : 13.01 to 36.00 MHz

## FEATURES

- 1) High frequency resonator to match high-speed needs
- 2) Faster start-up time as compared to quartz crystals
- 3) High durability
- 4) Bulk packaged 500 pieces per bag or 2000 pieces per reel
- 5) Sold in increments of 2000 pieces

## HOW TO ORDER

### KBR - 16.00 MSA TR

- ① Type: (Kyocera Bulk Resonator)
- ② Oscillation frequency (MHz)
- ③ Resonator type:  
MY = CMOS IC  
MSA = Standard
- ④ Packaging:  
□ = Bulk  
TR = Tape and reel



## SPECIFICATIONS (KBR-□MY/KBR-□MSA)

Series Type	KBR -MY	KBR -MSA
Frequency Range	13.01 to 15.99 MHz	16.00 to 36.00
Frequency Tolerance	±0.5%	±0.5%
Resonant Impedance	30 max.	30 max.
Temperature Characteristics (-20 to +80°C)	±0.3% max.	±0.3% max.

## DIMENSIONS

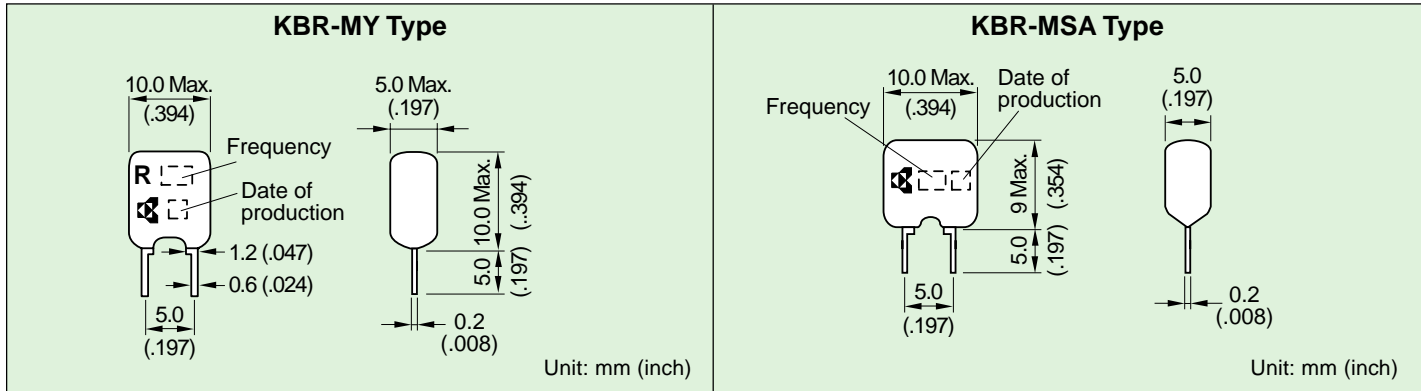

## STANDARD TEST CIRCUIT

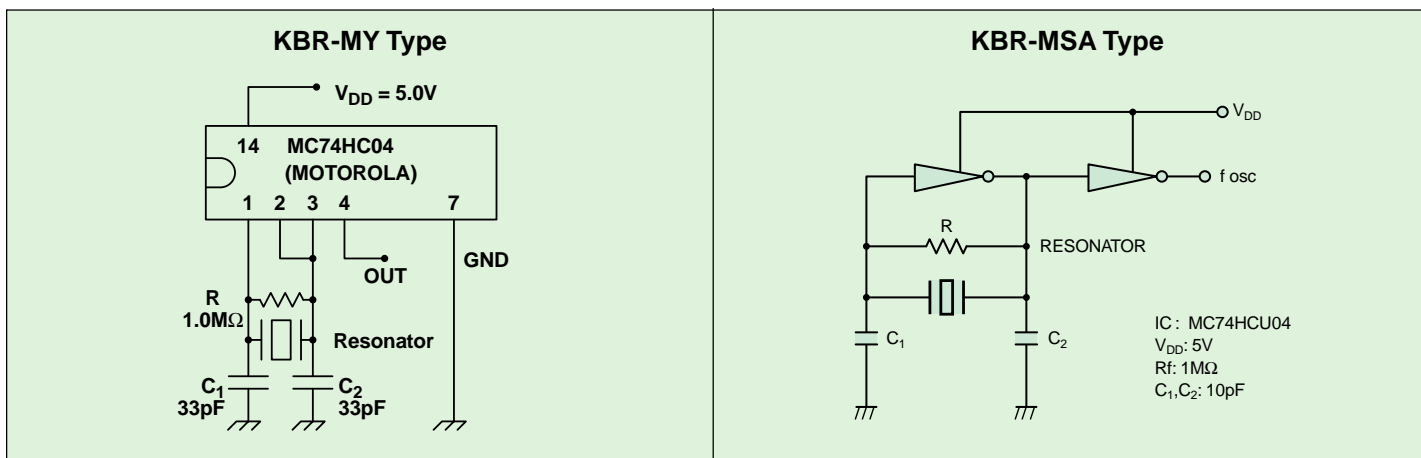

# KBR -MKC, -MKD, -MKS Series Ceramic Resonators

Built-in Capacitor MHz Band Ceramic Resonators  $f_o$ : 3.45 to 8.00 MHz  
16.00 to 36.00 MHz

## FEATURES

- 1) Built-in load capacitance
- 2) Simplified circuit
- 3) Reduced parts cost
- 4) Reduced mounting cost
- 5) High density mounting
- 5) Bulk packaged 500 pieces per bag or 2000 pieces per reel
- 7) Sold in increments of 2000 pieces

## HOW TO ORDER

**KBR - 4.00 MKC TR**

- ① Type: (Kyocera Bulk Resonator)
- ② Oscillation frequency (MHz)
- ③ Resonator type:  
MKC = "No-Clean" Process only  
MKD = Water resistant  
MKS = Standard
- ④ Packaging:  
□ = Bulk  
TR = Tape and reel



## SPECIFICATIONS (KBR-□MKC/KBR-□MKD/KBR-□MKS)

Series Type	KBR -MKC, -MKD, -MKS	KBR -MKD
Frequency Range	3.45 to 8.00 MHz	16.00 to 36.00
Frequency Tolerance	±0.5%	±0.5%
Resonant Impedance	30	30
Temperature Characteristics (-20 to +80°C)	±0.5%	±0.3%

## DIMENSIONS

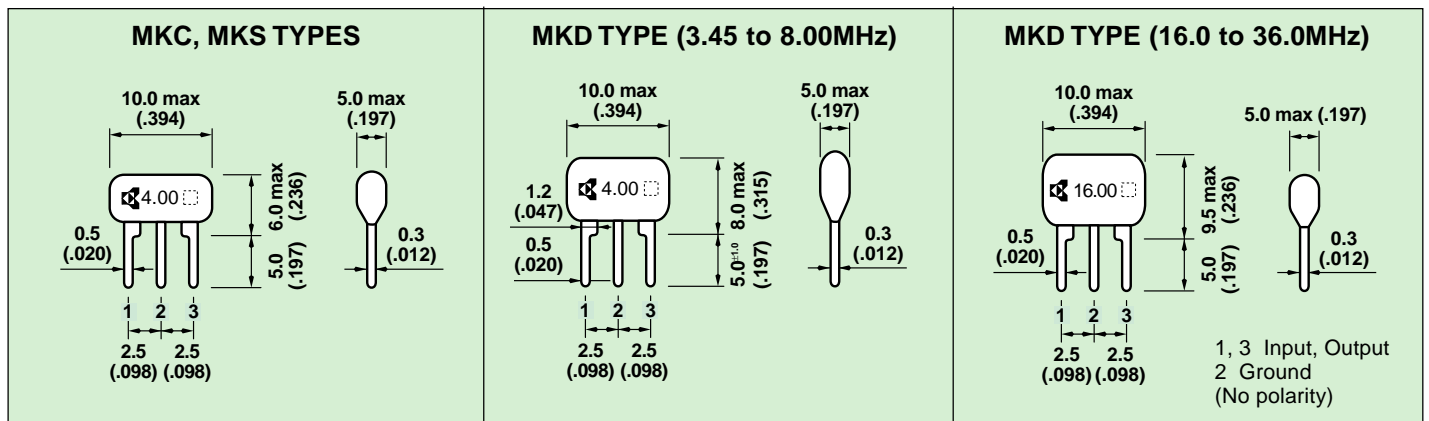

Unit: mm (inch)

Tolerance ±0.2mm unless otherwise specified

## TEST CIRCUIT

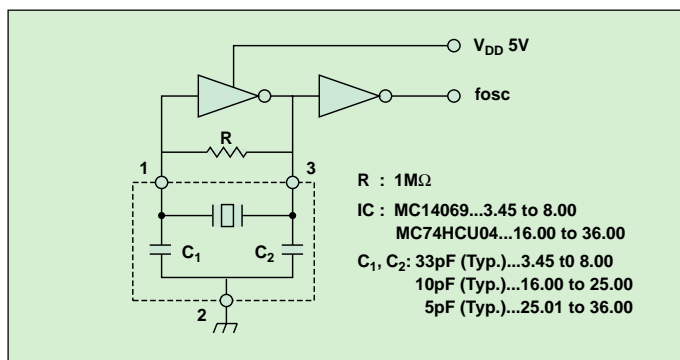

## PIN CONNECTION (No Polarity)

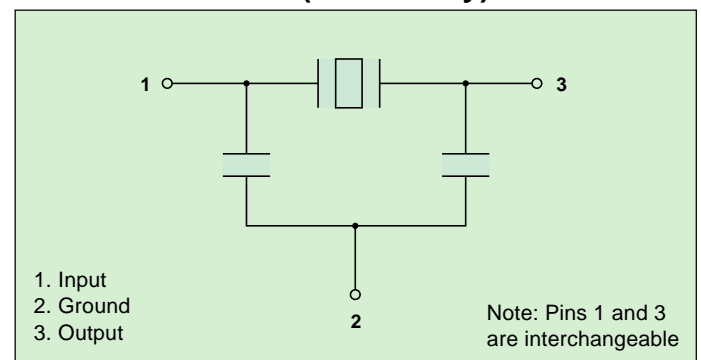

# Tape & Reel Packaging

## MHz Ceramic Resonators

### TAPE AND REEL PACKAGING

- 2000 pieces per reel
- Min. of 3 open positions at the beginning and end of tape

### AMMO PACK

- 2000 pieces per package
- A minimum of 38.1mm or three positions shall be open at beginning and end of tape
- Each fold shall be 317.35mm in length or the equivalent of twenty-five positions

### HOW TO ORDER

**KBR - [ ] [ ] TR**

- ①                      ②                      ③                      ④

- ① Type: (Kyocera Bulk Resonator)
- ② Oscillation frequency (MHz)
- ③ Resonator type = M/MS/MSA/MSB/MY/MKC/MKD
- ④ Packaging:  
TR = Tape and reel  
TF = Ammo pack

### TAPE DIMENSIONS

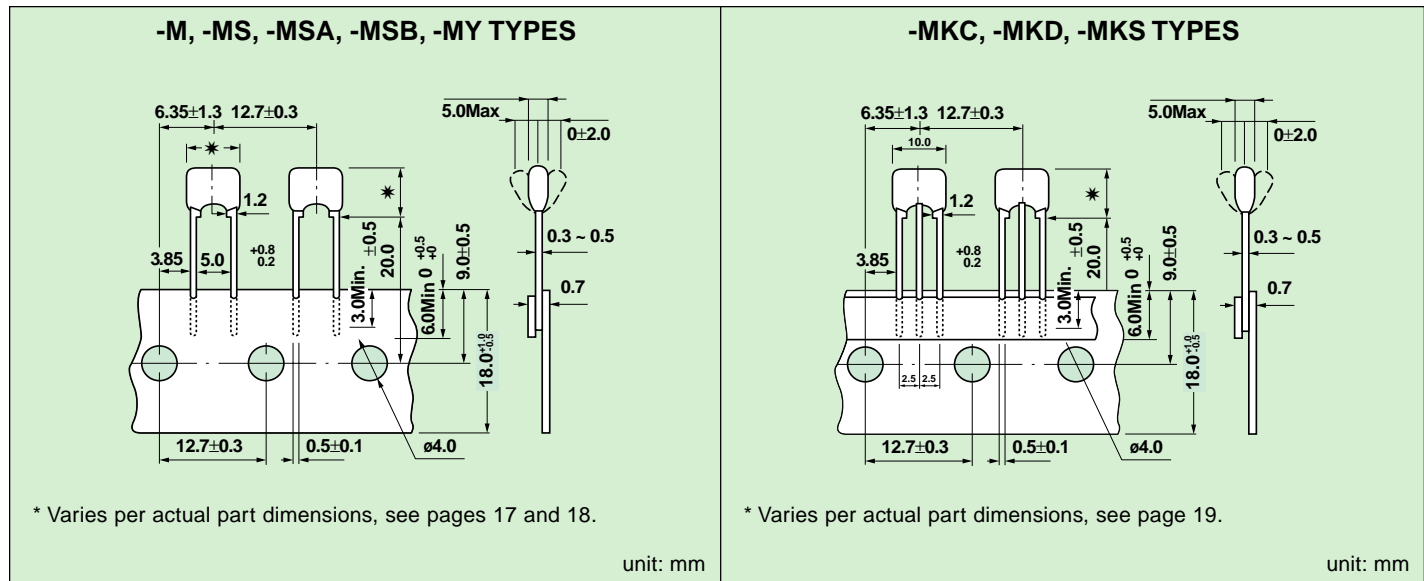

### REEL DIMENSIONS

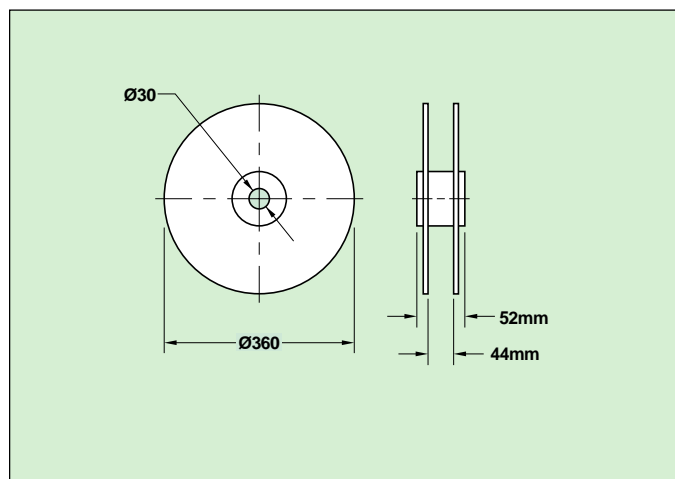

### AMMO PACK DIMENSIONS

