

MHz Band Ceramic Chip Resonators (SMD) PBRC-H/ PBRC-M/ PRQC Series



for Consumer Applications



RoHS Compliant

Features

- High reliability, high temperature withstanding package
- Rectangular shape allows easy pick and placement
- Small & low profile
- Reflow solderable
- Excellent solderability (Nickel barrier+Au flash terminations)

How to Order (PBRC-H, PBRC-M)

PBRC 15.00 H R 50 X 000
 ① ② ③ ④ ⑤ ⑥ ⑦

- ① Series
- ② Frequency (MHz)
- ③ Type (H, M)
- ④ Packing R: Reel (Null): Bulk
- ⑤ Frequency Tolerance at 25°C

10	±0.1%	20	±0.2%
30	±0.3%	40	±0.4%
50	±0.5%	70	±0.7%

- ⑥ Operating Temperature

X -40°C to 85°C

- ⑦ Unique Code

How to Order (PRQC)

PRQC 8.00 C R 50 10 X 000
 ① ② ③ ④ ⑤ ⑥ ⑦ ⑧

- ① Series
- ② Frequency (MHz)
- ③ Type (C, S)
- ④ Packing R: Reel (Null): Bulk
- ⑤ Frequency Tolerance at 25°C

30	±0.3%	40	±0.4%
50	±0.5%	70	±0.7%

- ⑥ Built-in Capacitance 10pF: 10

- ⑦ Operating Temperature

W -20°C to 80°C **X** -40°C to 85°C

- ⑧ Unique Code

Specifications

Series	Frequency Range (MHz)	Frequency Tolerance (25°C)	Temperature Stability
PBRC-H	2.00 to 8.00	±0.5% (op. ±0.3%)	±0.5% (-40 to 85°C)
	8.01 to 20.0	±0.7% (op. ±0.5%)	±0.1% (-40 to 85°C)
PBRC-M	4.00 to 8.00	±0.5% (op. ±0.3%)	±0.5% (-40 to 85°C)
	8.01 to 20.0	±0.7% (op. ±0.5%)	±0.1% (-40 to 85°C)
PRQC	8.00 to 20.0	±0.5% (op. ±0.3%)	±0.5% (-40 to 85°C)

* Aging for 10 years is within ±0.3% from the initial frequency at 25°C.

Test Circuit

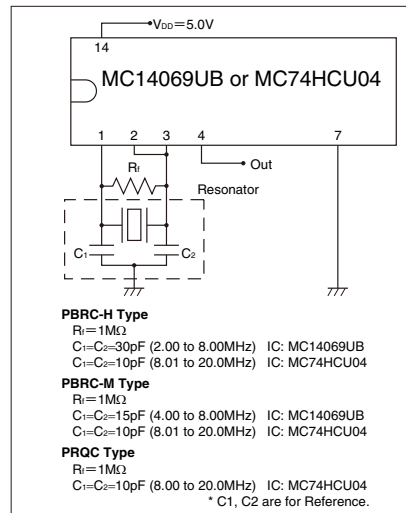

Note)

- This product includes built-in capacitors, but values may not be the most appropriate depending on IC's.
- Evaluation of circuit with IC is necessary. IC circuit matching may be referenced with
 - 1) IC data books
 - 2) List of Recommended circuits in Kyocera website.
- Please contact IC manufacturer or Kyocera when there are difficulties in finding recommended circuits.

Dimensions

(Unit: mm)

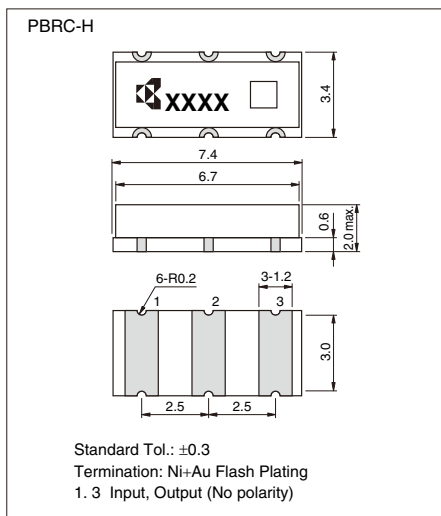

(Unit: mm)

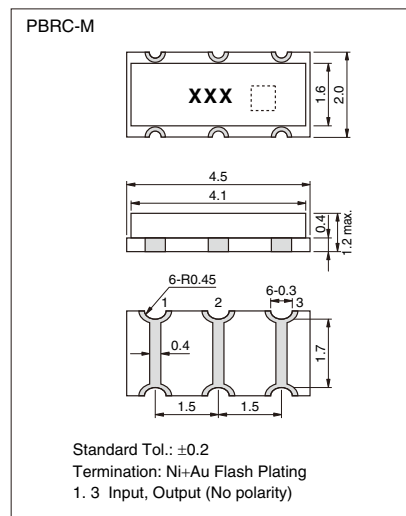

(Unit: mm)

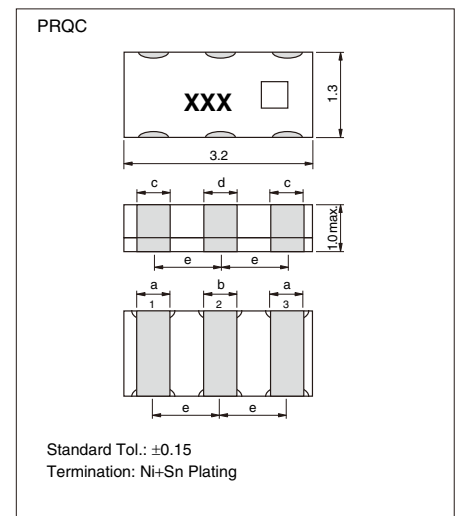

#	Pin #
1	Input
2	Ground
3	Output

(Unit: mm)

Type	Frequency (MHz)	a	b	c	d	e
C	8.00 to 13.99	0.4	0.4	0.6	0.4	1.2
S	14.00 to 20.00	0.6	0.4	0.6	0.4	0.95

MHz Band Ceramic Chip Resonators (SMD) PBRV-H/ PBRV-M/ PRQV Series



for Automotive Applications

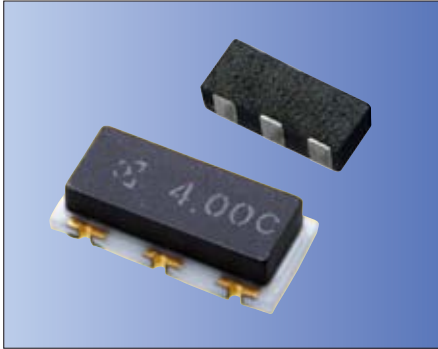

RoHS Compliant

Features

- Miniature & low profile
- Rectangular shape allows easy pick and placement
- Component cost and space saving
- High density mounting possible
- Reflow solderable & washable
- High reliability, high temperature operation
- AEC-Q200

Applications

- Automotive
- ABS
- ECU
- Air-Bag System

How to Order (PBRV-H, PBRV-M)

PBRV 15.00 H R 50 Y 000
 ① ② ③ ④ ⑤ ⑥ ⑦

- ① Series (PBRV: Automotive)
- ② Frequency (MHz)
- ③ Type (H, M)
- ④ Packing R: Reel
(Null): Bulk
- ⑤ Frequency Tolerance at 25°C

10	±0.1%	20	±0.2%
30	±0.3%	40	±0.4%
50	±0.5%	70	±0.7%

- ⑥ Operating Temperature

X	-40°C to 85°C	Y	-40°C to 125°C
Z	-40°C to 150°C		

- ⑦ Unique Code

How to Order (PRQV)

PRQV 8.00 C R 50 10 Y 000
 ① ② ③ ④ ⑤ ⑥ ⑦ ⑧

- ① Series (PRQV: Automotive)
- ② Frequency (MHz)
- ③ Type (C)
- ④ Packing R: Reel
(Null): Bulk
- ⑤ Frequency Tolerance at 25°C

30	±0.3%	40	±0.4%
50	±0.5%	70	±0.7%

- ⑥ Built-in Capacitance 10pF: 10

- ⑦ Operating Temperature

X	-40°C to 85°C	Y	-40°C to 125°C
Z	-40°C to 150°C		

- ⑧ Unique Code

Specifications

Series	Frequency Range (MHz)	Frequency Tolerance (25°C)	Temperature Stability
PBRV-H PBRV-M	4.00 to 8.00	±0.5% (op. ±0.3%)	Y: ±0.5% (-40 to +125°C) Z: ±0.5% (-40 to +150°C)
	8.01 to 20.00	±0.7% (op. ±0.5%)	Y: ±0.1% (-40 to +125°C) Z: ±0.2% (-40 to +150°C)
PRQV	8.00 to 20.00	±0.5% (op. ±0.3%)	Y: ±0.5% (-40 to +125°C) Z: ±0.5% (-40 to +150°C)

* Aging for 10 years is within ±0.3% from the initial frequency at 25°C.
 * Please contact us for products without built-in capacitors.

Note)

- This product includes built-in capacitors, but values may not be the most appropriate depending on IC's.
- Evaluation of circuit with IC is necessary. IC circuit matching may be referenced with
 - 1) IC data books
 - 2) List of Recommended circuits in Kyocera website.
- Please contact IC manufacturer or Kyocera when there are difficulties in finding recommended circuits.

Test Circuit

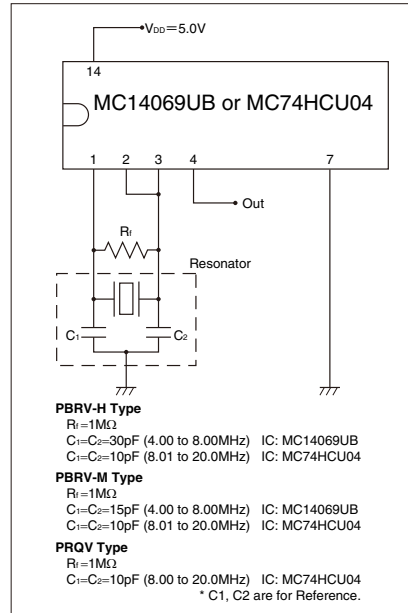

Dimensions

(Unit: mm)

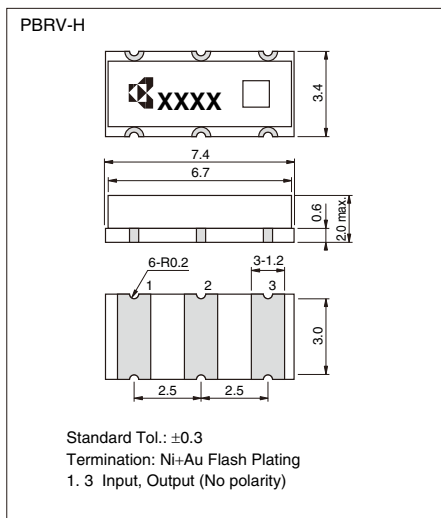

(Unit: mm)

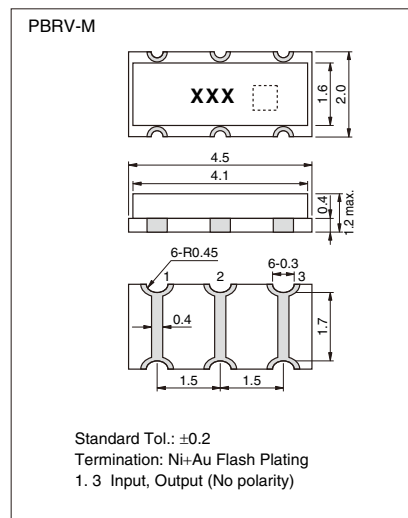

(Unit: mm)

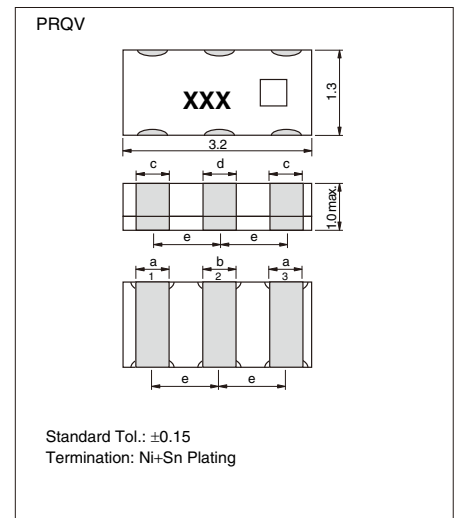

#	Pin #
1	Input
2	Ground
3	Output

(Unit: mm)

Type	Frequency (MHz)	a	b	c	d	e
C	8.00 to 20.00	0.4	0.4	0.6	0.4	1.2

MHz Band Ceramic Chip Resonators (SMD) PBRV/ PRQV Frequency Tight Tolerance Series



for Automotive Applications

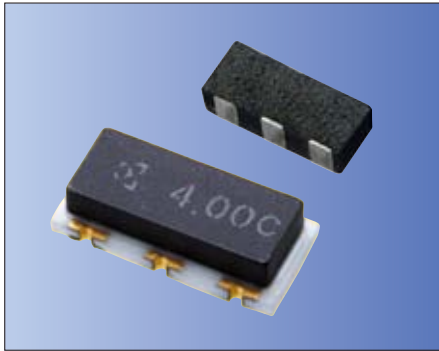

RoHS Compliant

Features

- Improved frequency tolerance for CAN-BUS application of automotive
- AEC-Q200

How to Order (PBRV)

PBRV 15.00 H R 10 Y 000
① ② ③ ④ ⑤ ⑥ ⑦

- ① Series (PBRV: Automotive)
- ② Frequency (MHz)
- ③ Type (H, M)
- ④ Packing R: Reel (Null): Bulk
- ⑤ Frequency Tolerance at 25°C

10 ±0.1%

- ⑥ Operating Temperature

X -40°C to 85°C Y -40°C to 125°C
Z -40°C to 150°C

- ⑦ Unique Code

How to Order (PRQV)

PRQV 8.00 C R 15 10 Y 000
① ② ③ ④ ⑤ ⑥ ⑦ ⑧

- ① Series (PRQV: Automotive)
- ② Frequency (MHz)
- ③ Type (C)
- ④ Packing R: Reel (Null): Bulk
- ⑤ Frequency Tolerance at 25°C

15 ±0.15%

- ⑥ Built-in Capacitance 10pF: 10
- ⑦ Operating Temperature

X -40°C to 85°C Y -40°C to 125°C
Z -40°C to 150°C

- ⑧ Unique Code

Specifications

Series	PBRV-H/ M	PRQV-C
Part Number	PBRV-HR/ MR 10Y □□□	PRQV- CR15 □□ Y □□□
Operating Temperature Range	-40 to +125°C	-40 to +125°C
Frequency Range	4.0 to 7.9MHz	8.0 to 20.0MHz
Frequency Tolerance	Initial: ±0.3%	±0.2%
Aging	±0.1%	±0.05%
Total Frequency Tolerance	±0.4%	±0.3%

* Please refer to the specification sheet of each product for information including detail dimensions.

* Aging characteristics is specified at 25°C for the period of 10 years.

Test Circuit

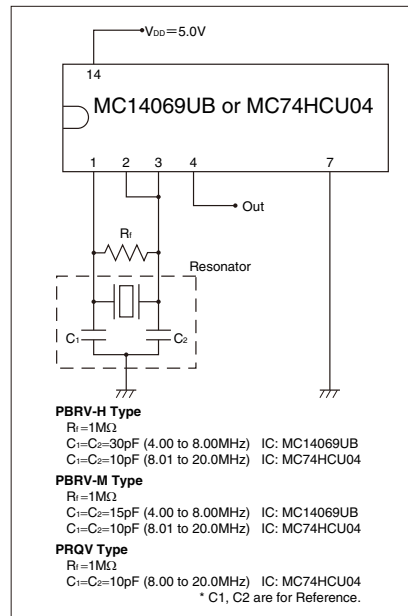

Dimensions

(Unit: mm)

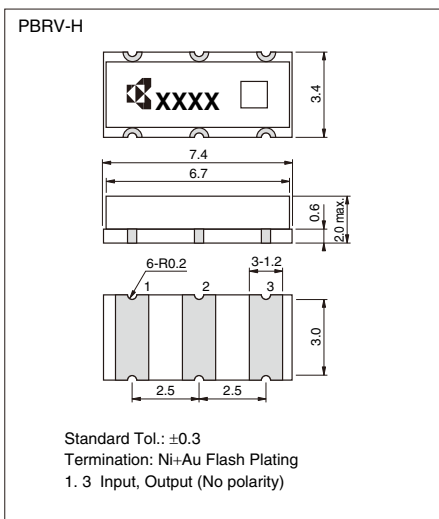

#	Pin #
1	Input
2	Ground
3	Output

(Unit: mm)

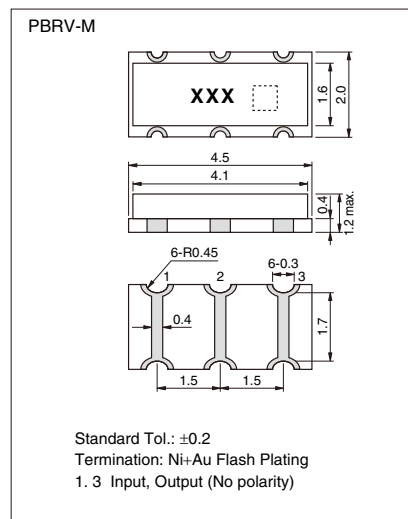

(Unit: mm)

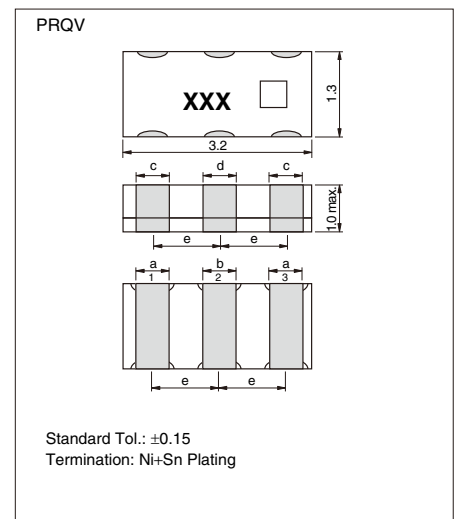

(Unit: mm)

Type	Frequency (MHz)	a	b	c	d	e
C	8.00 to 20.00	0.4	0.4	0.6	0.4	1.2

MHz Band Ceramic Chip Resonators (SMD) Recommended Land Pattern/ Packaging



Recommended Land Pattern

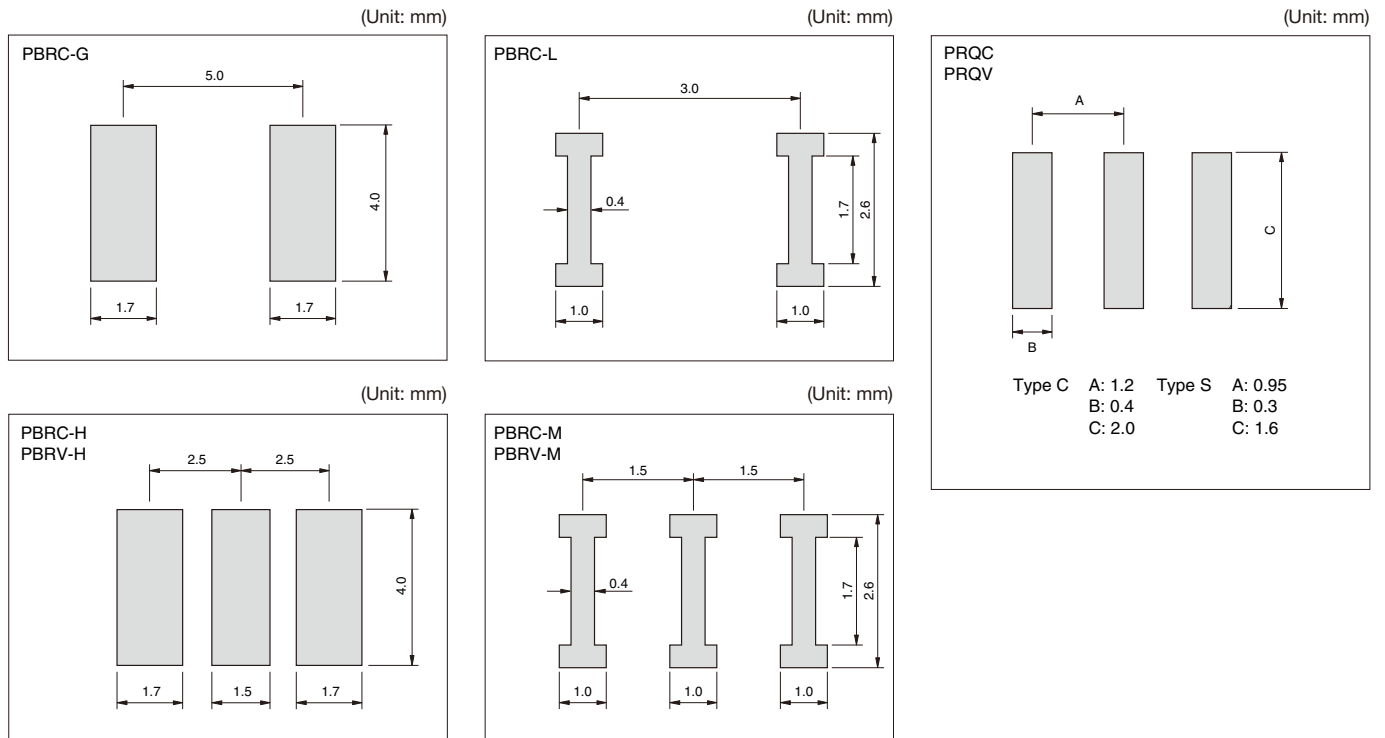

Packaging

Reel

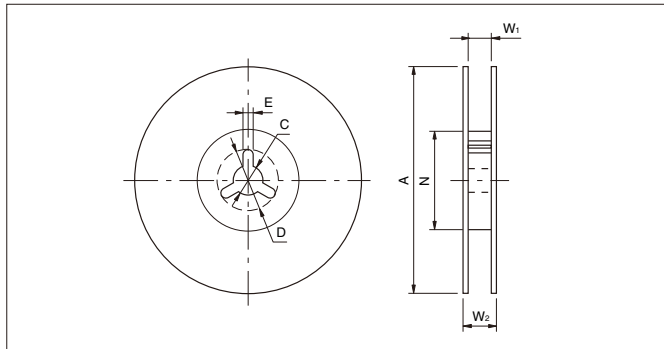

Taping

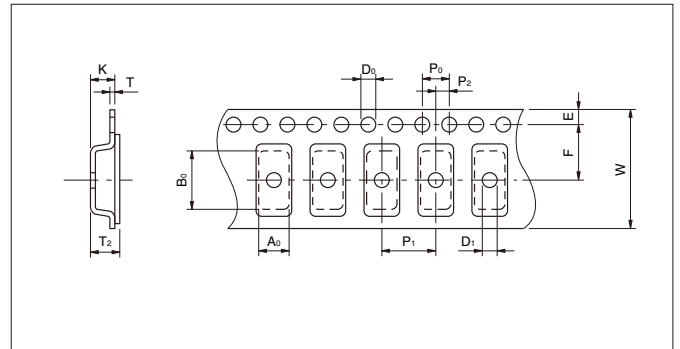

Code	A	N	W ₁	W ₂	C	D	E
7.4×3.4×2.0mm	250±2.0	80±2.0	16.5 ^{+1.1} _{-0.0}	23.6 max.	13.0±0.5	21.0±0.8	2.0±0.5
4.5×2.0×1.2mm	180 ⁺⁰ ₋₃	60 ⁺¹ ₋₀	13.0±0.3	15.4±1	13.0±0.2	21.0±0.8	2.0±0.5
3.2×1.3×1.3mm	180±2	60 ⁺¹ ₋₀	9.0 ^{+1.0} _{-1.5}	140 min.	13.0±0.2	21.0±0.8	2.0±0.5

Code	A ₀	B ₀	W	F	E	P ₁	P ₂	P ₀	D ₀	D ₁	T	T ₂	K
7.4×3.4×2.0mm	3.80±0.1	7.80±0.1	16.00±0.3	7.50±0.1	1.75±0.1	8.00±0.1	2.0±0.1	4.00±0.1	1.50 ^{+0.1} _{-0.0}	1.50 ^{+0.1} _{-0.0}	0.30±0.05	2.45±0.2	2.40±0.2
4.5×2.0×1.2mm	2.20±0.1	4.70±0.1	12.00±0.2	5.5±0.05	1.75±0.1	4.00±0.1	2.0±0.05	4.00±0.1	1.50 ^{+0.1} _{-0.0}	1.0±0.1	0.30±0.05	1.85 max.	1.80 max.
3.2×1.3×1.3mm	1.50±0.1	3.40±0.1	8.00±0.2	3.50±0.05	1.75±0.1	4.00±0.1	2.0±0.05	4.00±0.1	1.50 ^{+0.1} _{-0.0}	1.0±0.1	0.25±0.05	1.40 max.	1.10±0.05

* 7.4×3.4×2.0mm=PBRC-G, PBRC-H, PBRV-G, PBRV-H 2000 pcs./ Reel
 4.5×2.0×1.2mm=PBRC-L, PBRC-M, PBRV-L, PBRV-M 3000 pcs./ Reel
 3.2×1.3×1.0mm=PRQC, PRQV 3000 pcs./ Reel