

# Monitor Calibration Unit Operation Instructions



Made in America



Figure 1. Desco [98220](#) Monitor Calibration Unit

## Description

The Desco [98220](#) Monitor Calibration Unit is designed to simplify the process of calibrating Workstation Continuous Monitors. The unit allows the user to quickly and easily verify whether a tester is operating within specifications. The Monitor Calibration Unit is a passive device and requires no power source.

“A Compliance Verification Plan shall be established to ensure the Organization’s fulfillment of the technical requirements of the ESD Control Program Plan (ANSI/ESD S20.20-2007 section 7.3). The product qualification for the Continuous Monitors per ANSI/ESD S20.20-2007 Table 3 is “User defined” test method and required limits, and compliance verification is per ESD TR53 with the required limit being “Manufacturer defined.” Per ESD TR53 Compliance Verification “Compliance verification of the constant monitor device should follow the manufacturer’s instructions.”

## Packaging

- 1 Monitor Calibration Unit
- 1 Alligator Clip
- 1 Stacking Snap Banana Jack Adapter
- 1 Banana Jack to Wire Adapter
- 1 Certificate of Calibration

## Calibration Test Procedures

The Monitor Calibration Unit was specifically designed for use in calibration of Desco brand equipment. The following step by step procedures will cover calibration for specific test units. The procedures will not cover adjustment of the test equipment. For detailed information regarding adjustment of specific Desco brand testers contact our Customer Service Department at 909-627-8178.

## Calibrating the Full Time Continuous Monitor

The Full Time Continuous Monitor is available as following item number:

Item	Voltage
<a href="#">19225</a>	120 VAC

### TESTING THE OPERATOR CIRCUIT

**Step 1:** Connect the Calibration Unit’s banana plug wire labeled “GROUND” to a known ground. Do not plug the ground lead from the Calibration Unit to the monitor’s common point ground banana jack. There is a 47 kilohm resistance to ground.

**Step 2:** Insert the Calibration Unit’s banana plug labeled “OPERATOR” into the jack labeled “OPERATOR” on the Full Time Continuous Monitor (see Figure 2). Power the monitor.

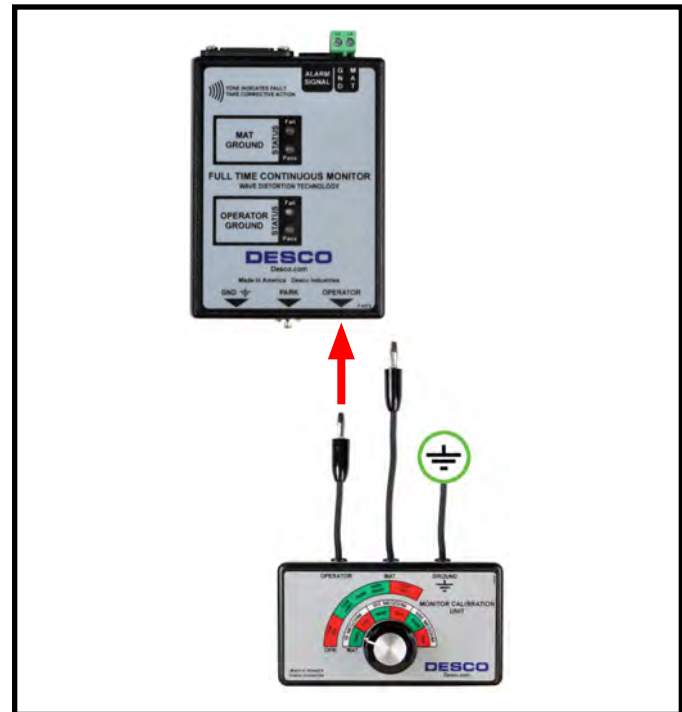

Figure 2. Connecting the OPERATOR test lead from the Monitor Calibration Unit to the Full Time Continuous Monitor

**Step 3:** Start the Calibration Unit’s selector knob at the full counter-clockwise position. When testing the OPERATOR circuit, test only the first four limits on the Calibration Unit. Rotate the selector knob to the “LOW FAIL” position; the red “OPERATOR GROUND” LED on the monitor should illuminate and alarm.

**Step 4:** Rotate the selector knob clockwise to the “LOW LIMIT” position of the green pass sector. The monitor’s green “OPERATOR GROUND” LED should illuminate.

**Step 5:** Rotate the selector knob clockwise to the “HIGH PASS” position at the end of the green pass sector. The monitor’s green “OPERATOR GROUND” LED should remain illuminated.

**Step 6:** Rotate the selector knob clockwise to the “HIGH FAIL” position. The green “OPERATOR GROUND” LED should turn off and the red LED should illuminate and the alarm should sound.

**Step 7:** Disconnect the Monitor Calibration Unit from the monitor.

**TESTING THE MAT CIRCUIT**

**Step 1:** Connect the Calibration Unit’s banana plug wire labeled “GROUND” to a known ground.

**Step 2:** Connect the included banana jack to wire adapter to the Calibration Unit’s banana plug labeled “MAT.” Insert the wire end of the adapter to the monitor’s green terminal block labeled “MAT” (see Figure 3).

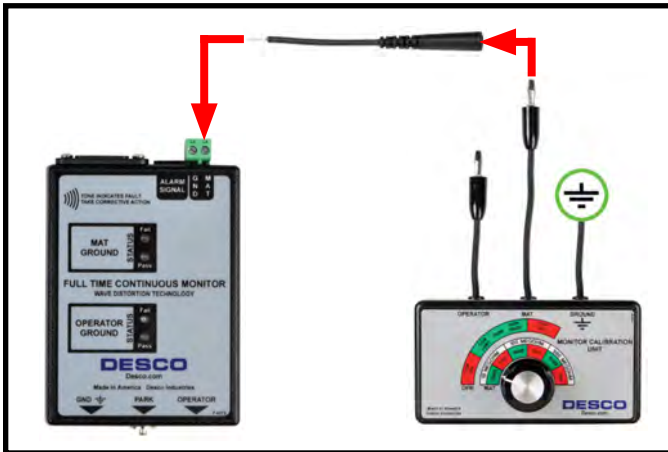

Figure 3. Connecting the MAT test lead from the Monitor Calibration Unit to the Full Time Continuous Monitor

**Step 3:** Rotate the Calibration Unit’s knob switch to the MAT FAIL 10M position. The monitor’s red “MAT GROUND” LED should illuminate and the alarm should sound.

**Step 4:** Rotate the selector knob counter-clockwise to the MAT PASS 10M position. The monitor’s “MAT GROUND” green LED should illuminate.

**Calibrating the Dual Operator Continuous Monitor with Two Satellites**

The Dual Operator Continuous Monitor with Two Satellites is available as following item numbers:

Item	Voltage
<a href="#">19232</a>	120 VAC
<a href="#">19233</a>	220 VAC

**Note:** If calibrating discontinued items 19208 or 19209, disconnect the remote jacks (if used) from the unit. Remote jacks may cause intermittencies in calibration. Leave the matt connection to the 19208 or 19209 in place.

**TESTING THE OPERATOR CIRCUIT**

**Step 1:** Connect the Calibration Unit’s banana plug wire labeled “GROUND” to a known ground.

**Step 2:** Insert the Calibration Unit’s banana plug labeled “OPERATOR” into the jack labeled “OPERATOR” on the satellite remote (see Figure 4).

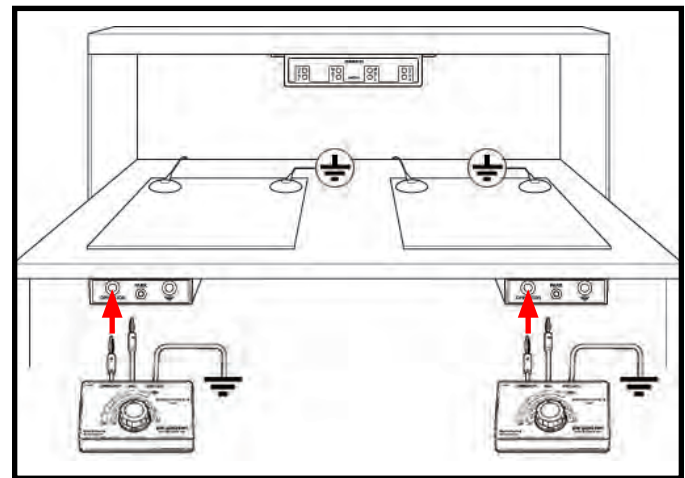

Figure 4. Connecting the OPERATOR test lead from the Monitor Calibration Unit to the satellite remote

**Step 3:** Start the Calibration Unit’s selector knob at the full counter-clockwise position and power the monitor. When testing the OPERATOR circuit, test only the first four limits on the Calibration Unit. Rotate the selector knob to the “LOW FAIL” position; the corresponding operator red LED on the monitor should illuminate and alarm.

**Step 4:** Rotate the selector knob clockwise to the “LOW LIMIT” position of the green pass sector. The monitor’s corresponding green “OPR1” or “OPR2” LED should illuminate.

**Step 5:** Rotate the selector knob clockwise to the “HIGH PASS” position at the end of the green pass sector. The monitor’s corresponding green “OPR1” or “OPR2” LED should remain illuminated.

**Step 6:** Rotate the selector knob clockwise to the “HIGH FAIL” position. The monitor’s corresponding green “OPR1” or “OPR2” LED should turn off and the red LED should illuminate and the alarm should sound.

**Step 7:** Disconnect the Monitor Calibration Unit from the satellite remote.

**Step 8:** Repeat this procedure for the remaining satellite remote.

**TESTING THE MAT CIRCUIT**

**Step 1:** Connect the Calibration Unit’s banana plug wire labeled “GROUND” to a known ground.

**Step 2:** Connect the included stacking snap to the banana plug labeled “MAT” on the Calibration Unit. Disconnect the satellite remote from its mat connection and re-install it to the Calibration Unit’s stacking snap (see Figure 5).

**Note:** The stacking snap must be isolated from the grounded mat.

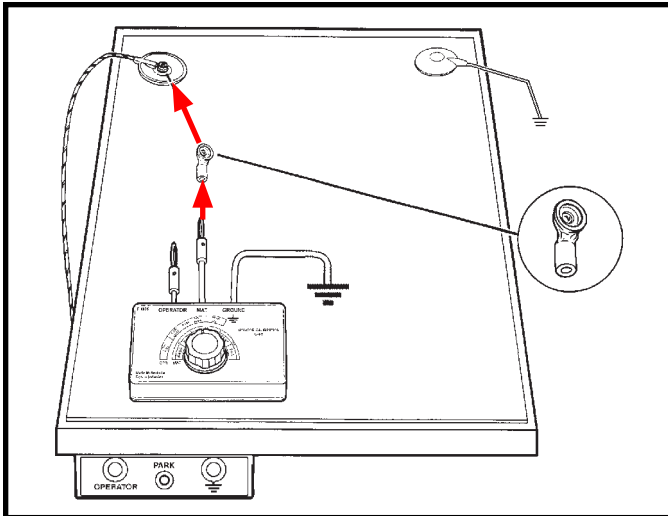

Figure 5. Connecting the MAT test lead from the Monitor Calibration Unit to the satellite remote

**Step 3:** Rotate the Calibration Unit’s knob switch to the MAT FAIL 10M position. The monitor’s corresponding red “MAT1” or “MAT2” LED should illuminate and the alarm should sound.

**Step 4:** Rotate the selector knob counter-clockwise to the MAT PASS 10M position. The monitor’s corresponding “MAT1” or “MAT2” green LED should illuminate.

**Note:** During FAIL LOW and FAIL HIGH, the monitor will continuously alarm until the banana lead is removed from the satellite remote. The alarm will shut off approximately 8-10 seconds after the removal of the banana lead.

**Step 5:** Repeat this procedure for the remaining satellite remote.

**Calibrating the Jewel® Workstation Continuous Mini Monitor**

The Jewel® Workstation Continuous Mini Monitor is available as following item numbers:

Item	Voltage
<a href="#">19212</a>	120 VAC

**TESTING THE OPERATOR CIRCUIT**

**Step 1:** Connect the Calibration Unit’s banana plug wire labeled “GROUND” to a known ground.

**Step 2:** Insert the Calibration Unit’s banana plug labeled “OPERATOR” into the jack labeled “OPERATOR” on the Jewel® Workstation Continuous Mini Monitor (see Figure 6).

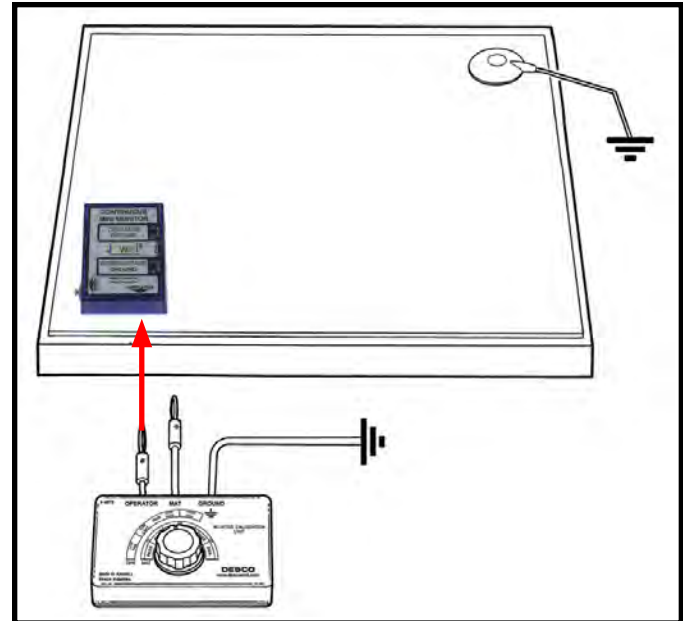

Figure 6. Connecting the OPERATOR test lead from the Monitor Calibration Unit to the Jewel® Workstation Continuous Mini Monitor

**Step 3:** Start the Calibration Unit’s selector knob at the full counter-clockwise position and power the monitor. When testing the OPERATOR circuit, test only the first four limits on the Calibration Unit. Rotate the selector knob to the “LOW FAIL” position; the red “OPERATOR GROUND” LED on the monitor should illuminate and alarm.

**Step 4:** Rotate the selector knob clockwise to the “LOW LIMIT” position of the green pass sector. The monitor’s green “OPERATOR GROUND” LED should illuminate.

**Step 5:** Rotate the selector knob clockwise to the “HIGH PASS” position at the end of the green pass sector. The monitor’s green “OPERATOR GROUND” LED should remain illuminated.

**Step 6:** Rotate the selector knob clockwise to the “HIGH FAIL” position. The green “OPERATOR GROUND” LED should turn off and the red LED should illuminate and the alarm should sound.

**Step 7:** Disconnect the Monitor Calibration Unit from the monitor.

### TESTING THE MAT CIRCUIT

**Step 1:** Connect the Calibration Unit’s banana plug wire labeled “GROUND” to a known ground.

**Step 2:** Connect the included stacking snap to the banana plug labeled “MAT” on the Calibration Unit. Detach the monitor from its mat connection and re-install the snap located underneath the LEDs to the Calibration Unit’s stacking snap (see Figure 7).

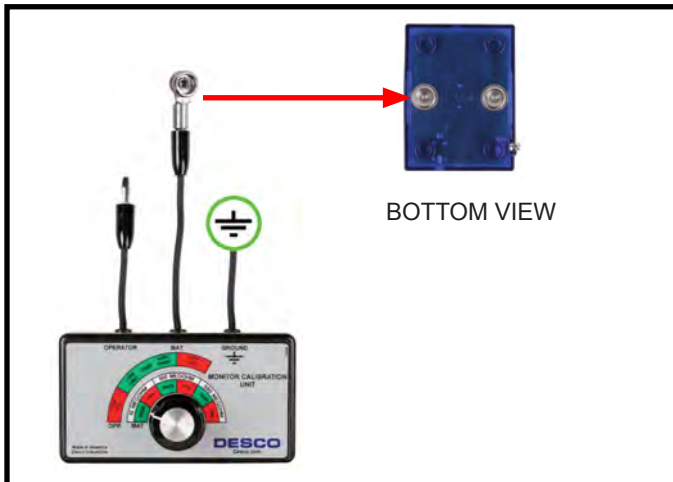

Figure 7. Connecting the MAT test lead from the Monitor Calibration Unit to the Jewel® Workstation Continuous Mini Monitor

**Step 3:** Rotate the Calibration Unit’s knob switch to the MAT FAIL 500M position. The monitor’s red “WORKSURFACE GROUND” LED should illuminate and the alarm should sound.

**Step 4:** Rotate the selector knob counter-clockwise to the MAT PASS 500M position. The monitor’s “WORKSURFACE GROUND” green LED should illuminate.

**Note:** During FAIL LOW and FAIL HIGH, the monitor will continuously alarm until the banana lead is removed from the satellite remote. The alarm will shut off approximately 8-10 seconds after the removal of the banana lead.

### Calibrating the Multi-Mount Continuous Monitor

The Multi-Mount Continuous Monitor is available as following item numbers:

Item	Voltage
<a href="#">19226</a>	120 VAC
<a href="#">19227</a>	220 VAC

### TESTING THE OPERATOR CIRCUIT

**Step 1:** Connect the Calibration Unit’s banana plug wire labeled “GROUND” to a known ground.

**Step 2:** Insert the Calibration Unit’s banana plug labeled “OPERATOR” into the jack labeled “OPR” on the Multi-Mount Continuous Monitor (see Figure 8).

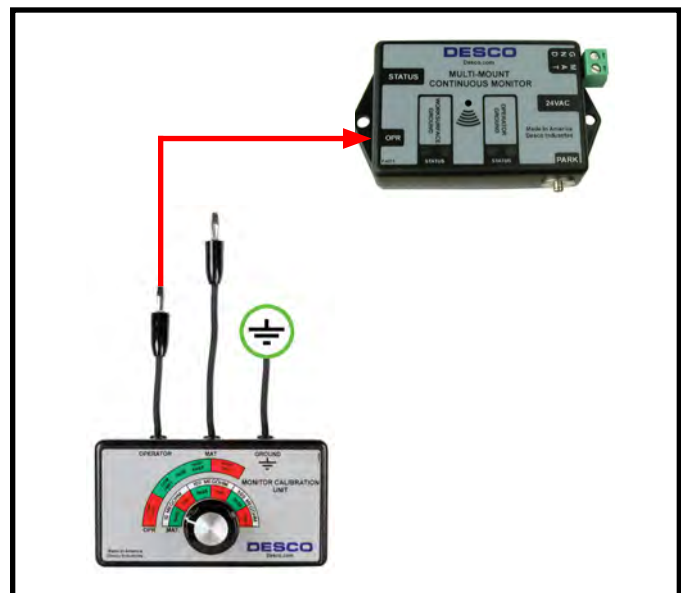

Figure 8. Connecting the OPERATOR test lead from the Monitor Calibration Unit to the Multi-Mount Continuous Monitor

**Step 3:** Start the Calibration Unit’s selector knob at the full counter-clockwise position and power the monitor. When testing the OPERATOR circuit, test only the first four limits on the Calibration Unit. Rotate the selector knob to the “LOW FAIL” position; the red “OPERATOR GROUND” LED on the monitor should illuminate and alarm.

**Step 4:** Rotate the selector knob clockwise to the “LOW LIMIT” position of the green pass sector. The monitor’s green “OPERATOR GROUND” LED should illuminate.

**Step 5:** Rotate the selector knob clockwise to the “HIGH PASS” position at the end of the green pass sector. The monitor’s green “OPERATOR GROUND” LED should remain illuminated.



**Step 6:** Rotate the selector knob clockwise to the “HIGH FAIL” position. The green “OPERATOR GROUND” LED should turn off and the red LED should illuminate and the alarm should sound.

**Step 7:** Disconnect the Monitor Calibration Unit from the monitor.

**TESTING THE MAT CIRCUIT**

**Step 1:** Connect the Calibration Unit’s banana plug wire labeled “GROUND” to a known ground.

**Step 2:** Connect the included banana jack to wire adapter to the Calibration Unit’s banana plug labeled “MAT.” Insert the other end of the wire to the monitor’s green terminal block labeled “MAT” (see Figure 9).

**Step 3:** Rotate the Calibration Unit’s knob switch to the MAT FAIL 10M position. The monitor’s red “WORKSURFACE GROUND” LED should illuminate and the alarm should sound.

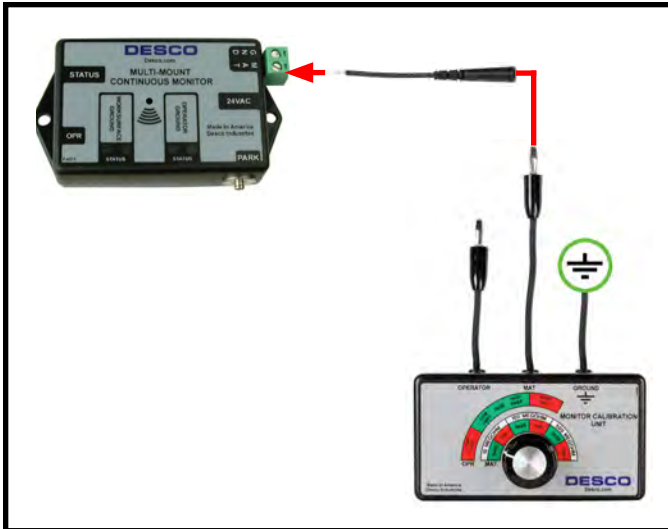

Figure 9. Connecting the MAT test lead from the Monitor Calibration Unit to the Multi-Mount Continuous Monitor

**Step 4:** Rotate the selector knob counter-clockwise to the MAT PASS 10M position. The monitor’s “WORKSURFACE GROUND” green LED should illuminate.

**Specifications**

Weight: 6.8 oz  
192 g

Dimensions: 4.5" x 2.5" x 1.2"  
11.4 cm x 6.4 cm x 3.0 cm

**Note:** The [98220](#) Monitor Calibration Unit also calibrates the following discontinued Desco items:

**Full Time Continuous Monitor**  
19210, 19211, 98210, 98211

**Dual Operator Continuous Monitor with Satellites**  
19208, 19209, 19230, 19231, 98207, 98208

**Jewel® Workstation Continuous Mini Monitor**  
19213, 19214, 19215, 19216, 19217

**Multi-Mount Continuous Monitor**  
19220, 19221, 19222, 19223, 98225, 98226, 98227, 98228

**Calibration**

Required Test Equipment: RLC Bridge

Settings:

For 50 Hz, Frequency = 1,000 Hz (20 x 50), 20th Harmonic

For 60 Hz, Frequency = 1,020 Hz (17 x 60), 17th Harmonic

Set function switch to read “equivalent parallel circuit”

Additional Required Test Equipment for [98220](#) MAT Resistance Measurement:

Megger: Set V compliance = 50V or less  
or

DMM: 50V power supply

Record Data for:

Serial #	Low Pass		Low Fail		High Pass		High Fail	
	Cp	Dis	Cp	Dis	Cp	Dis	Cp	Dis

Serial #	Mat Pass	Mat Fail	Megohms @ 50V

Compare with the following specs (tolerance = ± 10%):

	Equiv. Parallel C	Dissipation Factor
Low Fail	138.9 pF	0.158
Low Pass	118.6 pF	0.367
Hi Pass	49.0 pF	0.445
Hi Fail	44.7 pF	0.192

Mat (tolerance = ± 4%):

	Pass	Fail	V Measure ~ 50
10 Meg	8 Megohms	12 Megohms	
100 Meg	80 Megohms	120 Megohms	
500 Meg	400 Megohms	600 Megohms	

**Limited Warranty**

Desco expressly warrants that for a period of one (1) year from the date of purchase Desco Monitor Calibration Units will be free of defects in material (parts) and workmanship (labor). Within the warranty period, a credit for purchase of replacement Desco Monitor Calibration Units, or, at Desco's option, the Monitor Calibration Unit will be repaired or replaced free of charge. If product credit is issued, the amount will be calculated by multiplying the unused portion of the expected one year life times the original unit purchase price. Call our Customer Service Department at 909-627-8178 (Chino, CA) or 781-821-8370 (Canton, MA) for a Return Material Authorization (RMA) and proper shipping instructions and address. Please include a copy of your original packing slip, invoice, or other proof of date of purchase. Any unit under warranty should be shipped prepaid to the Desco factory. Warranty replacements will take approximately two weeks.

If your unit is out of warranty, call our Customer Service Department at 909-627-8178 (Chino, CA) or 781-821-8370 (Canton, MA) for a Return Material Authorization (RMA) and proper shipping instructions and address. Desco will quote repair charges necessary to bring your unit up to factory standards.

**Warranty Exclusions**

THE FOREGOING EXPRESS WARRANTY IS MADE IN LIEU OF ALL OTHER PRODUCT WARRANTIES, EXPRESSED AND IMPLIED, INCLUDING MERCHANTABILITY AND FITNESS FOR A PARTICULAR PURPOSE WHICH ARE SPECIFICALLY DISCLAIMED.

The express warranty will not apply to defects or damage due to accidents, neglect, misuse, alterations, operator error, or failure to properly maintain, clean or repair products.

**Limit of Liability**

In no event will Desco or any seller be responsible or liable for any injury, loss or damage, direct or consequential, arising out of the use of or the inability to use the product. Before using, users shall determine the suitability of the product for their intended use, and users assume all risk and liability whatsoever in connection therewith.