

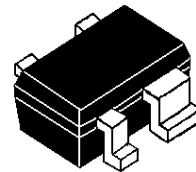

START450

NPN Silicon RF Transistor

- COMPRESSION POINT P1dB=19dBm @ 1.8GHz
- TRANSITION FREQUENCY 42GHz
- HIGH LINEARITY
- ULTRA MINIATURE SOT343(SC70) PACKAGE



SOT343 (SC70)

ORDER CODE
START450TR

BRANDING
450

DESCRIPTION

The START450 is a member of the START family that provide the state of the art of RF silicon process to the market. Manufactured in the third generation of ST proprietary bipolar process, it offers the best mix of gain and NF for given breakdown voltage(BVceo). It offers performance level only archived with GaAs products before.

APPLICATIONS

- LNA FOR GSM/GCS, DECT, PCS, PCN, CDMA, W-CDMA
- PREDRIVER FOR DECT
- GENERAL PURPOSE 500MHz-5GHz

ABSOLUTE MAXIMUM RATINGS

Symbol	Parameter	Value	Unit
V _{ceo}	Collector-emitter voltage	4.5	V
V _{cbo}	Collector-base voltage	15	V
V _{ebo}	Emitter-base voltage	1.5	V
I _c	Collector current	100	mA
I _b	Base current	10	mA
P _{tot}	Total dissipation, T _s = TBD	450	mW
T _{stg}	Storage temperature	-65 to 150	°C
T _j	Max. operating junction temperature	150	°C

ABSOLUTE MAXIMUM RATINGS

R _{thjs}	Thermal Resistance Junction soldering point	MAX	≤ 120	°C/W
-------------------	---	-----	-------	------

START450

ELECTRICAL CHARACTERISTICS ($T_j=25\text{ }^\circ\text{C}$, unless otherwise specified)

Symbol	Parameter	Test Conditions	Min.	Typ.	Max.	Unit
I_{cbo}	Collector cutoff current	$V_{cb} = 5V, I_e = 0A$			150	nA
I_{ebo}	Emitter-base cutoff current	$V_{eb} = 1.5V, I_c = 0A$			15	μA
Hfe	DC current gain	$I_c = 50mA, V_{ce} = 4V$		160		
NFmin	Minimum noise figure	$I_c = 10mA, V_{ce} = 2V, f = 1.8GHz, Z_s = Z_{sopt}$		1.2		dB
Ga	NFmin associated gain	$I_c = 10mA, V_{ce} = 2V, f = 1.8GHz$		13		dB
$ S_{21} ^2$	Insertion power gain	$I_c = 50mA, V_{ce} = 2V, f = 1.8GHz$		13.7		dB
Gms ⁽¹⁾	Maximum stable gain	$I_c = 50mA, V_{ce} = 2V, f = 1.8GHz$		19.1		dB
P _{-1dB}	1dB compression point	$I_c = 50mA, V_{ce} = 3V, f = 1.8GHz$		19		dBm
OIP3	Output third order intercept point	$I_c = 50mA, V_{ce} = 3V, f = 1.8GHz$		29		dBm

Note(1): $G_{ms} = |S_{21} / S_{12}|$

PINOUT

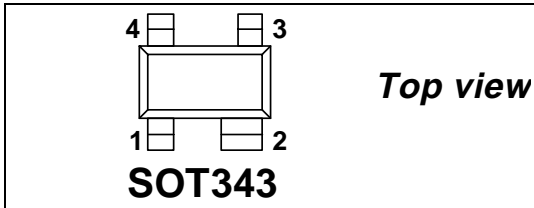

PIN CONNECTION

Pin No.	Description
1	BASE
3	COLLECTOR
2,4	EMITTER

SPICE PARAMETERS (Gummel-Poon Model, Berkley-SPICE 2G.6 Syntax)

TRANSISTOR CHIP DATA

Symbol	Value	Symbol	Value	Symbol	Value
TMEAS	27.0	FC	0.8	XJBC	0.3
IS	1.9E-16	EG	1.12	XTI	4.51
ISE	1.9E-12	NF	1	BF	295
NR	1	NE	2.658	VAF	40
ISC	3.19E-15	BR	13.7	VAR	2.5
IKF	{1.448*((T(°C)+273.15)/300.15)^(-1.6)}	NC	1.5	TF	3.1E-12
TR	7E-10	PTF	35	VTF	27
XTF	20	ITF	4.8	MJE	0.44
RB	2.7	RBM	0.64	MJC	0.31
RC	1.38	RE	0.15	MJS	0.281
CJE	1462E-15	VJE	1.1	IKR	43.5E-3
CJC	660E-15	VJC	0.84	XTB	-0.32
CJS	425E-15	VJS	0.453		

PACKAGE EQUIVALENT CIRCUIT

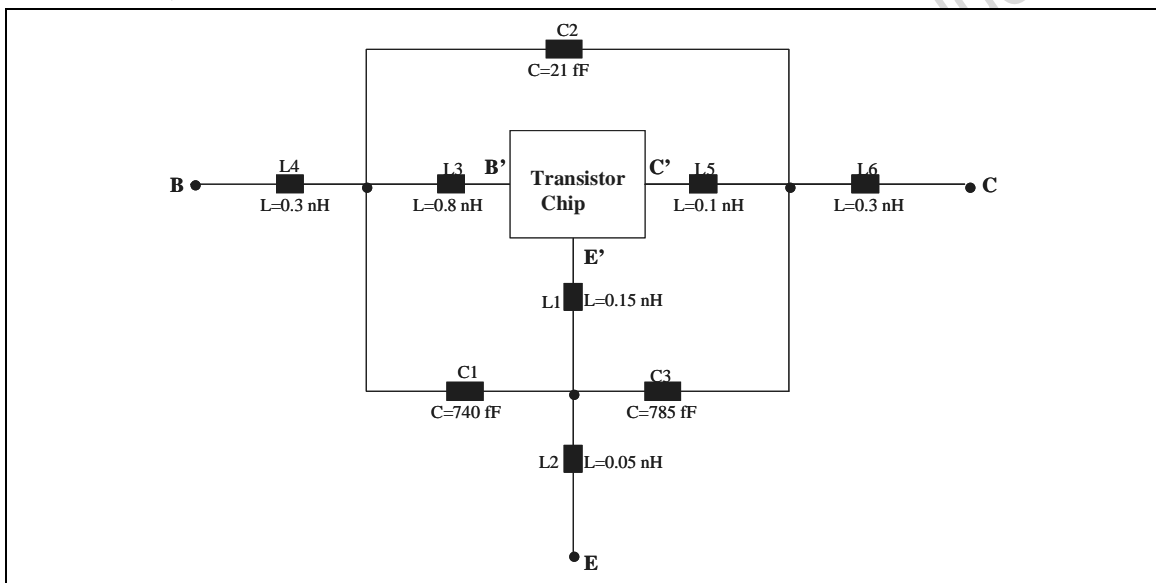

In order to avoid high complexity of the package equivalent circuit, the two emitter leads of SOT-343 package are combined in one electrical connection.

FOR MORE ACCURACY SIMULATION IN SATURATION REGION :

Adding the 5 Spice parameters showed in Table A and using **ST Spice Library** (available on request) you can achieve a more accuracy simulation in the saturation region. ST Spice library is compatible with following simulators: ELDO MENTOR (any version), SPECTRE CADENCE (any version), ADS (version 2001 only).

Table A (Spice Parameters extracted in saturation region)

RW	V _{jj}	ENP	VRP	RP
2.594	0.769	2.45	{4.64*((TEMPER+273.15)/300.15)^(1.5)}	1.00E-6



START450

COMMON EMITTER S-PARAMETERS ($V_{CE} = 2V$, $I_C = 50mA$)

FREQ (MHz)	$ S_{11} $	$S_{11}\angle\Phi$	$ S_{21} $	$S_{21}\angle\Phi$	$ S_{12} $	$S_{12}\angle\Phi$	$ S_{22} $	$S_{22}\angle\Phi$
0.1	0.572	-112	61.291	137	0.017	50	0.723	-75
0.5	0.740	-167	17.769	111	0.022	60	0.545	-149
0.9	0.747	-178	9.937	113	0.026	93	0.539	-163
1	0.744	179	8.736	114	0.025	103	0.534	-166
1.5	0.726	172	5.913	125	0.059	146	0.526	-171
1.8	0.715	167	4.893	128	0.060	157	0.520	-173
2	0.699	165	4.484	131	0.086	163	0.510	-175
2.5	0.646	158	3.661	139	0.128	172	0.481	-174
3	0.582	153	2.879	146	0.145	177	0.452	-173
3.5	0.523	150	2.195	154	0.189	170	0.449	-173
4	0.441	153	1.733	175	0.211	151	0.381	-178

Obsolete Product(s) - Obsolete Product(s)

TAPE & REEL DIMENSIONS

	mm		
	MIN.	TYP.	MAX
A	178.5	179	179.5
C	12.8	13.0	13.5
D	20.2		
N	54.5	55	55.5
T			14.4
Ao		2.25	
Bo		2.7	
Ko		1.2	
Po	3.8 (cumulative 10 Po)	4.0	4.2 (cumulative 10 Po)
P		4.0	

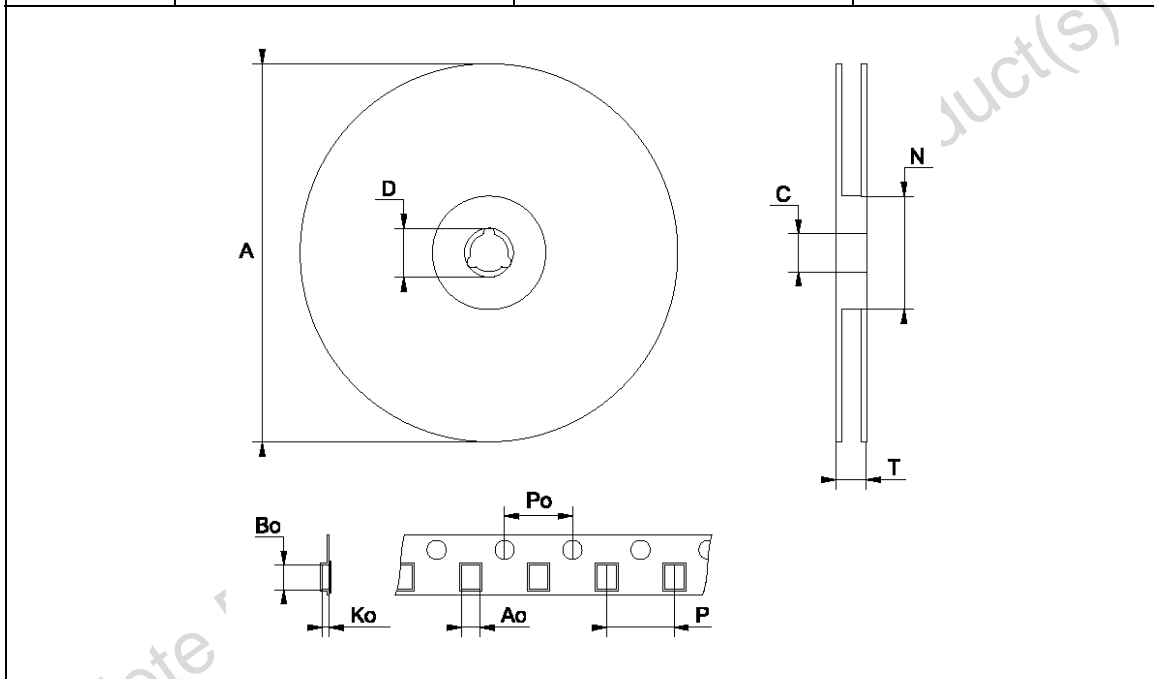

DEVICE ORIENTATION

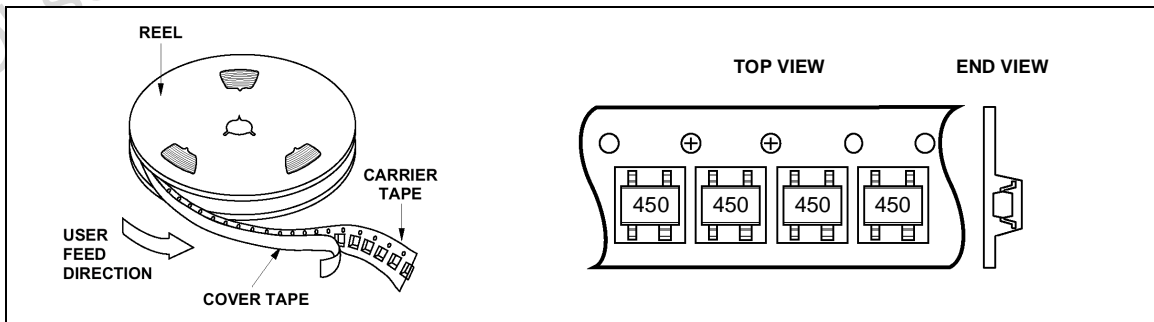

START450

PACKAGE DIMENSIONS SOT343 (SC-70 4 leads)

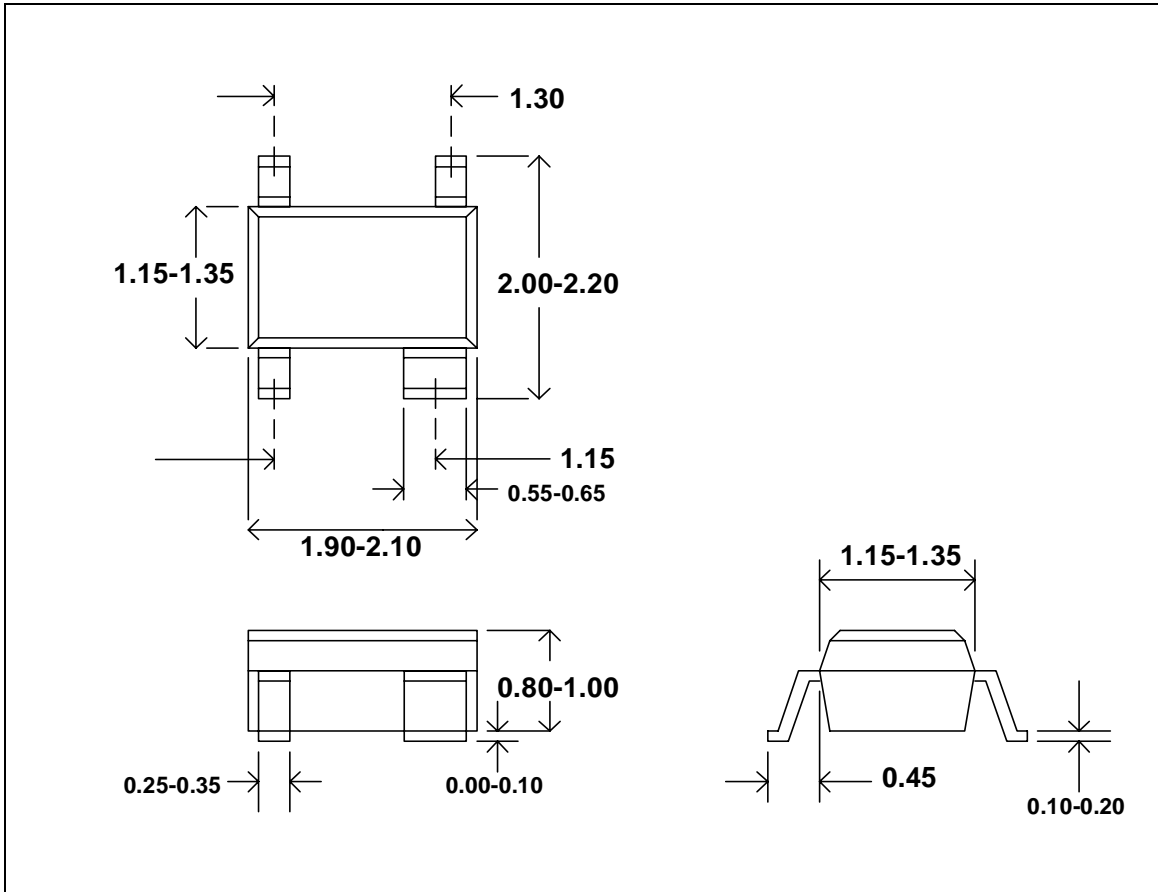

Obsolete Product(s)

Information furnished is believed to be accurate and reliable. However, STMicroelectronics assumes no responsibility for the consequences of use of such information nor for any infringement of patents or other rights of third parties which may result from its use. No license is granted by implication or otherwise under any patent or patent rights of STMicroelectronics. Specifications mentioned in this publication are subject to change without notice. This publication supersedes and replaces all information previously supplied. STMicroelectronics products are not authorized for use as critical components in life support devices or systems without express written approval of STMicroelectronics.

The ST logo is registered trademark of STMicroelectronics
© 2002 STMicroelectronics - All Rights Reserved

All other names are the property of their respective owners.

STMicroelectronics GROUP OF COMPANIES
Australia - Brazil - Canada - China - Finland - France - Germany - Hong Kong - India - Israel - Italy - Japan -
Malaysia - Malta - Morocco - Singapore - Spain - Sweden - Switzerland - United Kingdom - U.S.A.
<http://www.st.com>

