



NEC's C TO X BAND N-CHANNEL GaAs MES FET

NE722S01

FEATURES

- **HIGH POWER GAIN:**
GS = 6 dB TYP at f = 12 GHz
- **OUTPUT POWER** (at 1 dB compression):
15 dB TYP at f = 12 GHz
- **LOW NOISE/HIGH GAIN:**
NF = 0.9 dB TYP, Ga = 12 dB TYP at f = 4 GHz
- **GATE LENGTH:** LG = 0.8 μm (recessed gate)
- **GATE WIDTH:** WG = 400 μm

DESCRIPTION

NEC's NE722S01 is a low cost GaAs MESFET suitable for both amplifier and oscillator applications through X-band. The device features a 0.8 micron recessed gate, triple epitaxial technology and is fabricated using ion implantation for improved RF and DC performance and uniformity. This device's low phase noise and high fT makes it a excellent choice for oscillator applications on a digital LNB (Low Noise Block). The NE722S01 is housed in a low cost plastic package which is available in Tape and Reel.

NEC's stringent quality assurance and test procedures ensure the highest reliability performance.

APPLICATIONS

- C to X band low noise amplifiers
- C to X band oscillators

OUTLINE DIMENSION (Units in mm)

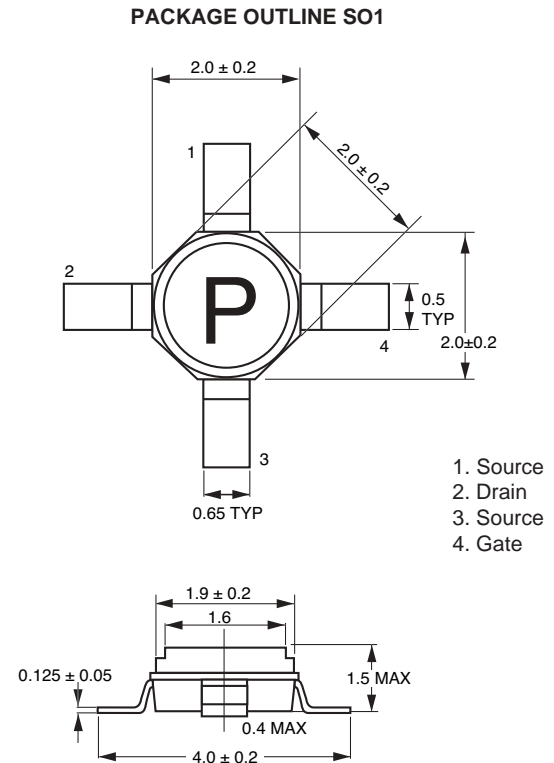

ELECTRICAL CHARACTERISTICS (TA = 25°C)

PART NUMBER PACKAGE OUTLINE			NE722S01 S01		
SYMBOLS	PARAMETERS AND CONDITIONS	UNITS	MIN	TYP	MAX
I _{GS0}	Gate to Source Leak Current, V _{GS} = -5 V	uA	-	1.0	10
I _{DSS}	Saturated Drain Current, V _{DS} = 3 V, V _{GS} = 0 V	mA	60	90	120
V _{GS}	Gate to Source Cutoff Voltage, V _{DS} = 3 V, I _D = 100 μA	V	-0.5	-	-4.0
g _m	Transconductance, V _{DS} = 3 V, I _{DS} = 30 mA	mS	20	45	-
G _s	Power Gain, V _{DS} = 3 V, I _{DS} = 30 mA, f = 12 GHz	dB	-	6	-
P _{1dB}	Output Power at 1 dB Gain Compression Point at V _{DS} = 3 V, I _{DS} = 30 mA, f = 12 GHz	dBm	-	15.0	-
NF	Noise Figure, V _{DS} = 3 V, I _{DS} = 10 mA, f = 4 GHz	dB	-	0.9	-
G _a	Associated Gain, V _{DS} = 3 V, I _{DS} = 10 mA, f = 4 GHz	dB	-	12	-

ABSOLUTE MAXIMUM RATINGS¹ (T_A = 25°C)

SYMBOLS	PARAMETERS	UNITS	RATINGS
V _{DS}	Drain to Source Voltage	V	5.0
V _{GS}	Gate to Source Voltage	V	-5.0
V _{GD}	Gate to Drain Voltage	V	-6.0
I _{DS}	Drain Current	mA	I _{DSS}
P _T	Total Power Dissipation	mW	250
P _{IN}	Input Power	mW	40
T _{CH}	Channel Temperature	°C	125
T _{STG}	Storage Temperature	°C	-65 to +125

Note:

1. Operation in excess of any one of these parameters may result in permanent damage.

TYPICAL PERFORMANCE CURVES (T_A = 25°C)

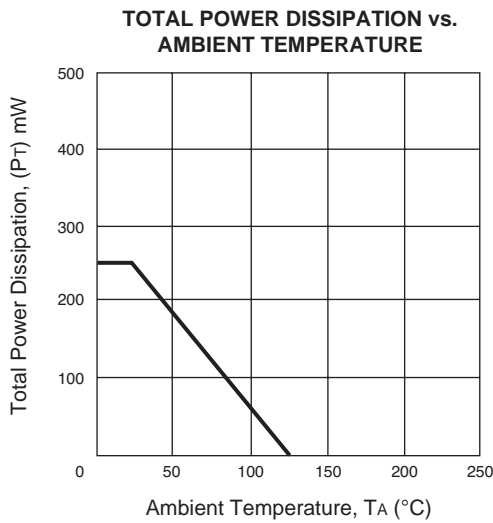

RECOMMENDED OPERATING CONDITIONS (T_A = 25°C)

PART NUMBER			NE722S01		
SYMBOLS	PARAMETERS	UNITS	MIN	TYP	MAX
V _{DS}	Drain to Source Voltage	V		3	4
I _{DS}	Drain Current	mA		30	40

ORDERING INFORMATION

PART NUMBER	SUPPLY FORM	MARKING
NE722S01-T1	Tape & Reel 1000 pcs/reel	P
NE722S01-T1B1	Tape & Reel 4000 pcs/reel	

Note:

1. Available if quantity is over 100k per month

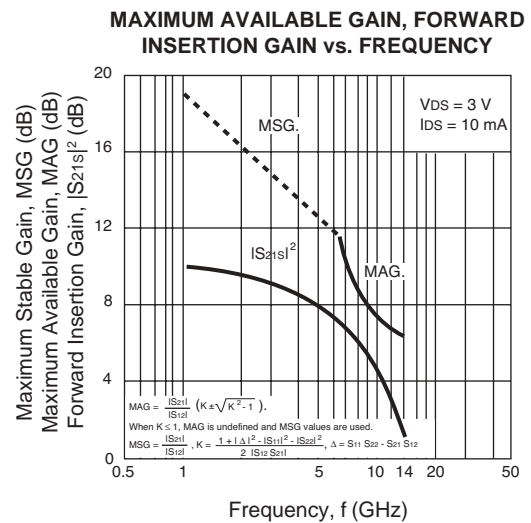
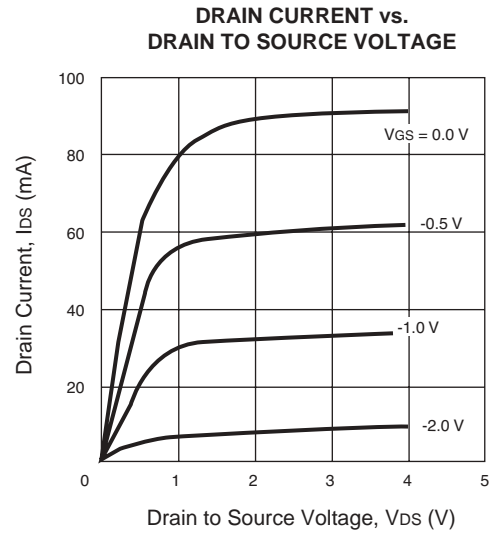
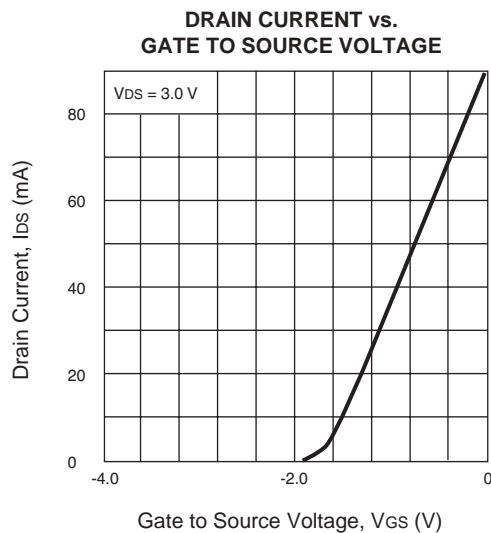

Note:

1. Gain Calculation:

$$MAG = \frac{|S_{21}|}{|S_{12}|} (K \pm \sqrt{K^2 - 1})$$

When $K \leq 1$, MAG is undefined and MSG values are used. $MSG = \frac{|S_{21}|}{|S_{12}|}$, $K = \frac{1 + |\Delta|^2 - |S_{11}|^2 - |S_{22}|^2}{2 |S_{12} S_{21}|}$, $\Delta = S_{11} S_{22} - S_{21} S_{12}$

MAG = Maximum Available Gain
 MSG = Maximum Stable Gain

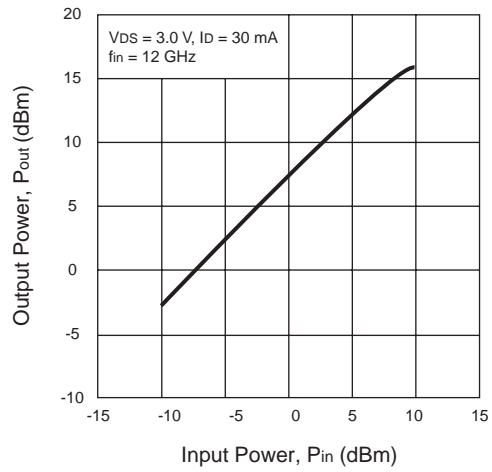
TYPICAL PERFORMANCE CURVES ($T_A = 25^\circ\text{C}$)**OUTPUT POWER vs. INPUT POWER**

TYPICAL SCATTERING PARAMETERS (T_A = 25°C)

NE722S01

V_{DS} = 3.0 V, I_{DS} = 10 mA

FREQUENCY GHz	S ₁₁		S ₂₁		S ₁₂		S ₂₂	
	MAG	ANG	MAG	ANG	MAG	ANG	MAG	ANG
2.0	0.912	-44.0	3.100	136.2	0.077	59.0	0.659	-30.2
2.5	0.876	-56.1	3.037	124.9	0.091	51.2	0.629	-38.0
3.0	0.828	-68.0	2.935	113.9	0.105	42.9	0.597	-46.4
3.5	0.784	-79.3	2.819	103.7	0.115	36.2	0.570	-53.5
4.0	0.737	-89.5	2.696	94.2	0.124	30.0	0.546	-60.9
4.5	0.699	-99.3	2.589	85.3	0.130	24.7	0.529	-67.2
5.0	0.660	-109.0	2.499	76.6	0.136	19.1	0.514	-73.6
5.5	0.620	-119.0	2.420	67.9	0.140	14.1	0.495	-79.6
6.0	0.583	-130.6	2.355	59.4	0.146	9.1	0.475	-85.2
6.5	0.547	-143.8	2.283	50.1	0.148	3.8	0.447	-91.5
7.0	0.516	-158.5	2.196	41.0	0.151	-1.6	0.408	-97.0
7.5	0.496	-173.7	2.098	32.2	0.149	-6.6	0.366	-103.7
8.0	0.500	172.6	2.016	23.7	0.152	-10.1	0.331	-110.8
8.5	0.510	159.9	1.920	15.3	0.150	-13.6	0.298	-120.4
9.0	0.526	148.4	1.834	7.2	0.151	-17.3	0.274	-133.2
9.5	0.540	138.4	1.749	-0.6	0.151	-20.3	0.265	-147.9
10.0	0.553	129.9	1.676	-7.9	0.152	-23.2	0.275	-160.7
10.5	0.566	120.6	1.608	-15.8	0.156	-26.3	0.297	-172.7
11.0	0.576	111.3	1.542	-23.5	0.157	-29.8	0.312	178.5
11.5	0.592	101.8	1.470	-31.1	0.157	-32.9	0.328	171.0
12.0	0.608	92.8	1.401	-38.4	0.158	-35.7	0.340	163.5
12.5	0.640	85.2	1.325	-45.7	0.159	-38.0	0.339	155.6
13.0	0.665	79.1	1.256	-52.7	0.160	-41.3	0.341	145.5
13.5	0.693	73.3	1.183	-59.7	0.158	-44.5	0.356	133.8
14.0	0.718	69.3	1.111	-66.4	0.162	-47.0	0.386	122.3
14.5	0.744	64.8	1.045	-73.3	0.163	-49.5	0.421	111.6
15.0	0.759	59.6	0.966	-79.7	0.159	-53.4	0.474	104.4
15.5	0.756	55.5	0.893	-85.4	0.159	-55.8	0.516	98.7
16.0	0.750	51.0	0.839	-91.0	0.160	-57.6	0.563	95.8
16.5	0.738	45.4	0.777	-96.7	0.158	-61.4	0.601	92.8
17.0	0.728	40.9	0.714	-101.5	0.158	-63.1	0.624	89.4
17.5	0.721	36.4	0.676	-105.7	0.156	-65.9	0.628	86.9
18.0	0.721	32.5	0.624	-109.8	0.158	-68.4	0.625	82.2

Note:

1. Gain Calculation:

$$MAG = \frac{|S_{21}|}{|S_{12}|} (K \pm \sqrt{K^2 - 1}). \text{ When } K \leq 1, \text{ MAG is undefined and MSG values are used. } MSG = \frac{|S_{21}|}{|S_{12}|}, K = \frac{1 + |\Delta|^2 - |S_{11}|^2 - |S_{22}|^2}{2 |S_{12} S_{21}|}, \Delta = S_{11} S_{22} - S_{21} S_{12}$$

MAG = Maximum Available Gain

MSG = Maximum Stable Gain

TYPICAL SCATTERING PARAMETERS (T_A = 25°C)

NE722S01

V_{ds} = 3.0 V, I_{ds} = 30 mA

FREQUENCY GHz	S ₁₁		S ₂₁		S ₁₂		S ₂₂	
	MAG	ANG	MAG	ANG	MAG	ANG	MAG	ANG
2.0	0.896	-48.3	3.721	134.0	0.063	59.9	0.547	-29.6
2.5	0.851	-61.5	3.606	122.4	0.077	53.2	0.519	-37.4
3.0	0.799	-74.1	3.449	111.3	0.086	45.1	0.489	-45.4
3.5	0.753	-86.1	3.275	101.1	0.095	39.6	0.464	-52.6
4.0	0.705	-97.0	3.102	91.6	0.102	34.1	0.443	-59.5
4.5	0.666	-107.3	2.957	82.7	0.106	29.5	0.431	-65.5
5.0	0.625	-117.5	2.834	74.0	0.111	24.9	0.419	-71.5
5.5	0.586	-128.3	2.724	65.3	0.115	20.6	0.406	-76.9
6.0	0.553	-140.6	2.627	56.8	0.122	17.0	0.390	-82.2
6.5	0.521	-154.2	2.522	47.7	0.125	12.6	0.366	-88.2
7.0	0.497	-169.4	2.402	39.0	0.128	8.5	0.334	-93.4
7.5	0.489	175.8	2.281	30.5	0.128	5.0	0.296	-99.7
8.0	0.501	162.9	2.176	22.5	0.131	1.8	0.267	-106.8
8.5	0.519	151.0	2.062	14.5	0.135	-1.2	0.234	-117.8
9.0	0.540	140.4	1.963	6.8	0.139	-3.4	0.209	-132.7
9.5	0.562	131.2	1.865	-0.7	0.142	-6.8	0.206	-150.0
10.0	0.575	123.2	1.786	-7.8	0.146	-9.9	0.221	-164.3
10.5	0.589	114.3	1.709	-15.4	0.151	-12.8	0.246	-177.2
11.0	0.602	105.5	1.637	-22.9	0.156	-16.7	0.265	-173.7
11.5	0.619	96.4	1.554	-30.2	0.161	-20.5	0.285	166.1
12.0	0.633	88.0	1.480	-37.4	0.163	-23.9	0.299	158.1
12.5	0.666	80.9	1.400	-44.5	0.168	-27.4	0.303	149.9
13.0	0.690	75.2	1.321	-51.1	0.171	-30.5	0.307	139.1
13.5	0.715	70.0	1.241	-57.9	0.173	-33.9	0.326	127.4
14.0	0.740	66.4	1.169	-64.2	0.173	-37.3	0.358	116.2
14.5	0.769	62.0	1.101	-70.8	0.174	-41.0	0.396	106.2
15.0	0.780	57.0	1.021	-77.1	0.178	-45.3	0.450	99.5
15.5	0.778	52.5	0.945	-82.6	0.175	-48.6	0.494	94.8
16.0	0.774	48.2	0.888	-88.0	0.176	-51.4	0.540	92.0
16.5	0.759	42.7	0.824	-93.4	0.176	-56.1	0.578	89.4
17.0	0.750	38.1	0.767	-98.3	0.174	-58.3	0.601	86.3
17.5	0.739	33.9	0.721	-102.3	0.175	-61.1	0.604	84.0
18.0	0.741	30.2	0.672	-106.6	0.176	-63.3	0.599	79.2

Note:

1. Gain Calculation:

$$\text{MAG} = \frac{|S_{21}|}{|S_{12}|} \left(K \pm \sqrt{K^2 - 1} \right). \text{ When } K \leq 1, \text{ MAG is undefined and MSG values are used. } \text{MSG} = \frac{|S_{21}|}{|S_{12}|}, K = \frac{1 + |\Delta|^2 - |S_{11}|^2 - |S_{22}|^2}{2 |S_{12}| |S_{21}|}, \Delta = S_{11} S_{22} - S_{21} S_{12}$$

MAG = Maximum Available Gain

MSG = Maximum Stable Gain

NONLINEAR MODEL

SCHEMATIC

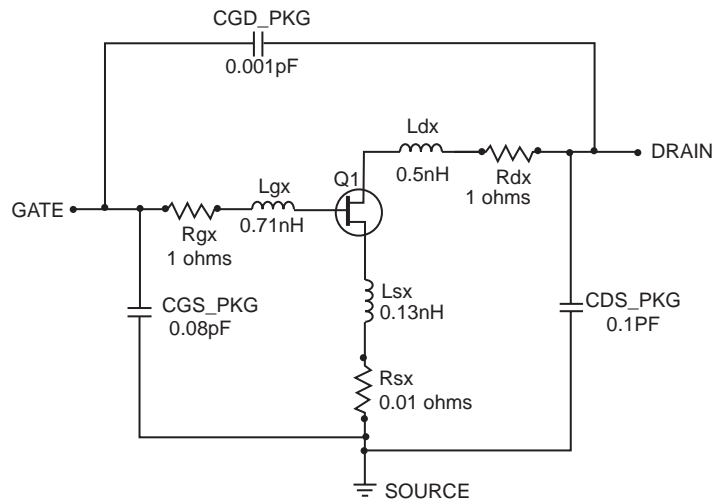

FET NONLINEAR MODEL PARAMETERS ⁽¹⁾

Parameters	Q1	Parameters	Q1
VTO	-2.24	RG	8
VTOSC	0	RD	0.5
ALPHA	8	RS	6
BETA	0.055	RGMET	0
TQGAMMA	0.04	TNOM	27
TQGAMMAAC	0.05	XTI	3
Q	1.5	EG	1.43
TQDELTA	0.25	VTOTC	0
VBI	1	BETATCE	0
IS	1e-14	FFE	1
N	1.3	FNC ⁽²⁾	150e-6
RIS	0	R	0.5
RID	0	P	1
TAU	3e-12	C	0.9
CDS	0.19e-12		
RDB	250		
CBS	1e-9		
CGS	0.92e-12		
CGD	0.05e-12		
DELTA1	0.3		
DELTA2	0.3		
FC	0.5		
VBR	Infinity		

(1) ADS TOM Model

(2) To simulate phase noise using AF/KF: AF = 1.5 KF = 2e-10

Life Support Applications

These NEC products are not intended for use in life support devices, appliances, or systems where the malfunction of these products can reasonably be expected to result in personal injury. The customers of CEL using or selling these products for use in such applications do so at their own risk and agree to fully indemnify CEL for all damages resulting from such improper use or sale.

CEL California Eastern Laboratories, Your source for NEC RF, Microwave, Optoelectronic, and Fiber Optic Semiconductor Devices.

4590 Patrick Henry Drive • Santa Clara, CA 95054-1817 • (408) 988-3500 • FAX (408) 988-0279 • www.cel.com

DATA SUBJECT TO CHANGE WITHOUT NOTICE

UNITS

Parameter	Units
time	seconds
capacitance	farads
inductance	henries
resistance	ohms
voltage	volts
current	amps

MODEL RANGE

Frequency: 0.1 to 18 GHz

Bias: $V_{DS} = 2\text{ V to }4\text{ V}$, $I_D = 10\text{ mA to }40\text{ mA}$

Date: 02/2002