

HIGH VOLTAGE POWER SCHOTTKY RECTIFIER

MAIN PRODUCT CHARACTERISTICS

$I_{F(AV)}$	3 A
V_{RRM}	60 V
$V_F(\text{max})$	0.59 V

PRELIMINARY DATASHEET

FEATURES AND BENEFITS

- NEGLIGIBLE SWITCHING LOSSES
- LOW FORWARD DROP VOLTAGE
- LOW CAPACITANCE
- HIGH REVERSE AVALANCHE SURGE CAPABILITY
- TAPE AND REEL OPTION : -TR

DESCRIPTION

High voltage Schottky rectifier suited to Switch Mode Power Supplies and other Power Converters.

Packaged in DPAK, this device is intended for use in medium voltage operation, and particularly, in high frequency circuitries where low switching losses are required.

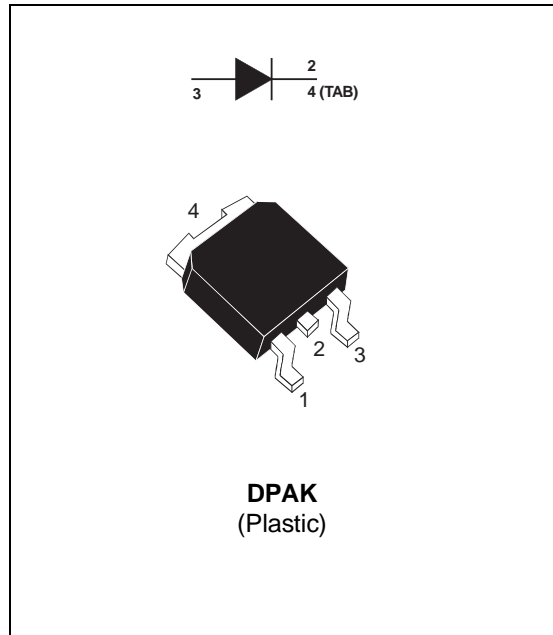

ABSOLUTE MAXIMUM RATINGS

Symbol	Parameter		Value	Unit
V_{RRM}	Repetitive Peak Reverse Voltage		60	V
$I_{F(RMS)}$	RMS Forward Current		6	A
$I_{F(AV)}$	Average Forward Current	$T_{case} = 120^{\circ}\text{C}$ $\delta = 0.5$	3	A
I_{FSM}	Surge Non Repetitive Forward Current	$t_p = 10\text{ ms}$ Sinusoidal	50	A
I_{RRM}	Repetitive Peak Reverse Current	$t_p = 2\ \mu\text{s}$ $F = 1\text{KHz}$	1	A
T_{stg}	Storage Temperature Range		- 65 to + 150	$^{\circ}\text{C}$
T_j	Max. Junction Temperature		150	$^{\circ}\text{C}$
dV/dt	Critical Rate of Rise of Reverse Voltage		1000	$\text{V}/\mu\text{s}$

STPS360B(-TR)

THERMAL RESISTANCES

Symbol	Parameter	Value	Unit
$R_{TH(j-c)}$	Junction to Case Thermal Resistance	3.5	°C/W

STATIC ELECTRICAL CHARACTERISTICS

Symbol	Tests Conditions	Tests Conditions	Min.	Typ.	Max.	Unit
I_R^*	Reverse leakage Current	$T_j = 25^\circ\text{C}$	$V_R = 60\text{ V}$		30	μA
		$T_j = 125^\circ\text{C}$		2.5	10	mA
V_F^{**}	Forward Voltage drop	$T_j = 25^\circ\text{C}$	$I_F = 3\text{ A}$		0.65	V
		$T_j = 125^\circ\text{C}$		0.55	0.59	

Pulse test : * $t_p = 380\ \mu\text{s}$, duty cycle < 2 %

** $t_p = 5\ \text{ms}$, duty cycle < 2%

To evaluate the maximum conduction losses use the following equation :

$$P = 0.49 \times I_{F(AV)} + 0.035 I_{F(RMS)}^2$$

Typical junction capacitance, $V_R = 0\text{V}$ $F = 1\text{MHz}$ $T_j = 25^\circ\text{C}$ $C = 815\text{pF}$

PACKAGE MECHANICAL DATA
DPAK

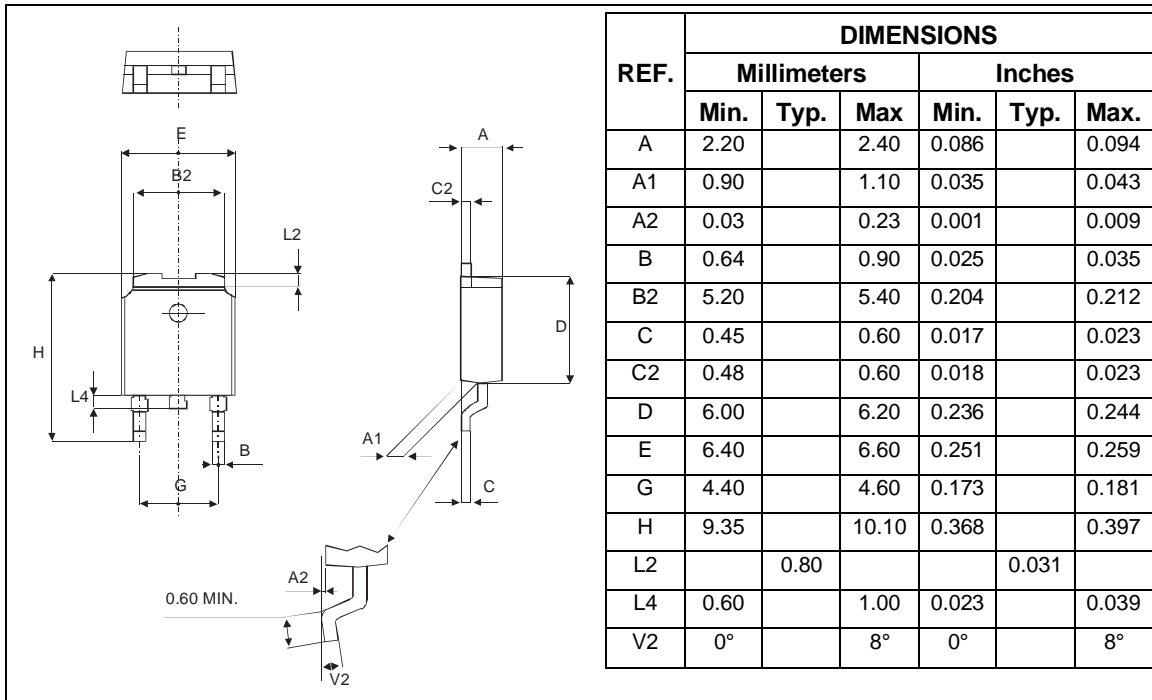

Information furnished is believed to be accurate and reliable. However, SGS-THOMSON Microelectronics assumes no responsibility for the consequences of use of such information nor for any infringement of patents or other rights of third parties which may result from its use. No license is granted by implication or otherwise under any patent or patent rights of SGS-THOMSON Microelectronics. Specifications mentioned in this publication are subject to change without notice. This publication supersedes and replaces all information previously supplied. SGS-THOMSON Microelectronics products are not authorized for use as critical components in life support devices or systems without express written approval of SGS-THOMSON Microelectronics.

© 1995 SGS-THOMSON Microelectronics - Printed in Italy - All rights reserved.

SGS-THOMSON Microelectronics GROUP OF COMPANIES

Australia - Brazil - France - Germany - Hong Kong - Italy - Japan - Korea - Malaysia - Malta - Morocco - The Netherlands - Singapore - Spain - Sweden - Switzerland - Taiwan - Thailand - United Kingdom - U.S.A.