

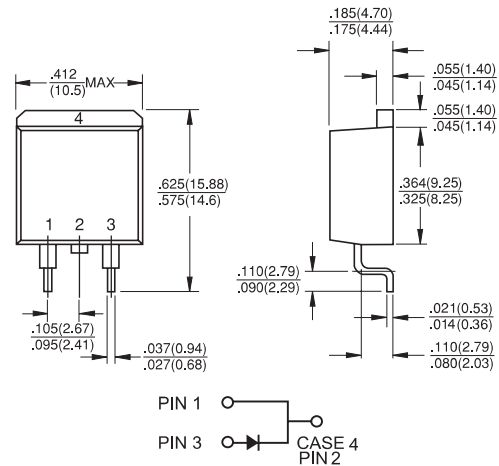

Features

- ✦ Plastic material used carries Underwriters Laboratory Classifications 94V-0
- ✦ Metal silicon junction, majority carrier conduction
- ✦ Low power loss, high efficiency
- ✦ High current capability, low forward voltage drop
- ✦ High surge capability
- ✦ For use in low voltage, high frequency inverters, free wheeling, and polarity protection applications
- ✦ Guardring for overvoltage protection
- ✦ High temperature soldering guaranteed: 260°C/10 seconds, 0.25" (6.35mm) from case



Mechanical Data

- ✦ Cases: JEDEC D²PAK molded plastic body
- ✦ Terminals: Pure tin plated, lead free. solderable per MIL-STD-750, Method 2026
- ✦ Polarity: As marked
- ✦ Mounting position: Any
- ✦ Mounting torque: 5 in. - lbs. max
- ✦ Weight: 0.08 ounce, 2.24 grams

Dimensions in inches and (millimeters)

Maximum Ratings and Electrical Characteristics

Rating at 25 °C ambient temperature unless otherwise specified.

Single phase, half wave, 60 Hz, resistive or inductive load.

For capacitive load, derate current by 20%

Type Number	Symbol	MBRS 1635	MBRS 1645	MBRS 1650	MBRS 1660	MBRS 1690	MBRS 16100	MBRS 16150	Units
Maximum Recurrent Peak Reverse Voltage	V_{RRM}	35	45	50	60	90	100	150	V
Maximum RMS Voltage	V_{RMS}	24	31	35	42	63	70	105	V
Maximum DC Blocking Voltage	V_{DC}	35	45	50	60	90	100	150	V
Maximum Average Forward Rectified Current at $T_c=125^\circ\text{C}$	$I_{(AV)}$	16							A
Peak Repetitive Forward Current (Rated V_R , Square Wave, 20KHz) at $T_c=125^\circ\text{C}$	I_{FRM}	32.0							A
Peak Forward Surge Current, 8.3 ms Single Half Sine-wave Superimposed on Rated Load (JEDEC method)	I_{FSM}	150							A
Peak Repetitive Reverse Surge Current (Note 1)	I_{RRM}	1.0	0.5					A	
Maximum Instantaneous Forward Voltage at: (Note 2) $I_F=16\text{A}, T_c=25^\circ\text{C}$ $I_F=16\text{A}, T_c=125^\circ\text{C}$	V_F	0.63 0.57	0.75 0.65		0.85 0.82		0.95 0.92	V	
Maximum Instantaneous Reverse Current @ $T_c=25^\circ\text{C}$ at Rated DC Blocking Voltage (Note 2) @ $T_c=125^\circ\text{C}$	I_R	0.5 15	0.5 10		0.3 7.5		0.1 5.0	mA mA	
Maximum Typical Thermal Resistance (Note 3)	$R_{\theta JC}$	1.5							$^\circ\text{C}/\text{W}$
Operating Junction Temperature Range	T_J	-65 to +150							$^\circ\text{C}$
Storage Temperature Range	T_{STG}	-65 to +175							$^\circ\text{C}$

- Notes:
1. 2.0us Pulse Width, $f=1.0$ KHz
 2. Pulse Test: 300us Pulse Width, 1% Duty Cycle
 3. Thermal Resistance from Junction to Case Per Leg

RATINGS AND CHARACTERISTIC CURVES (MBRS1635 THRU MBRS16150)

FIG.1- FORWARD CURRENT DERATING CURVE

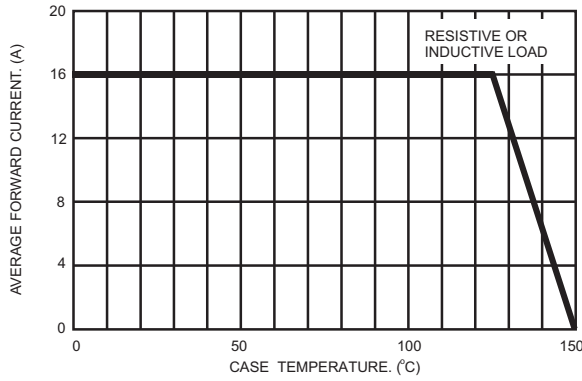

FIG.2- MAXIMUM NON-REPETITIVE FORWARD SURGE CURRENT

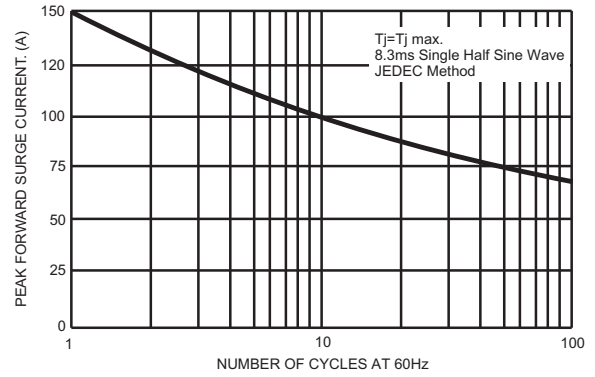

FIG.3- TYPICAL INSTANTANEOUS FORWARD CHARACTERISTICS

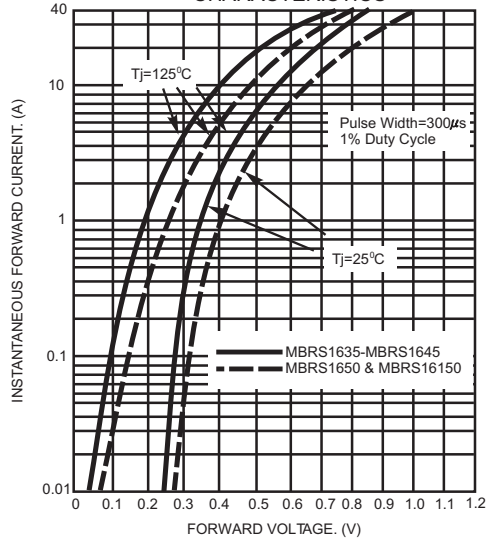

FIG.4- TYPICAL REVERSE CHARACTERISTICS

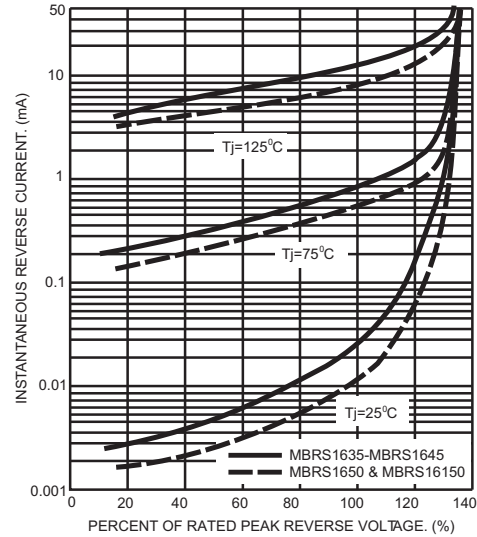

FIG.5- TYPICAL JUNCTION CAPACITANCE

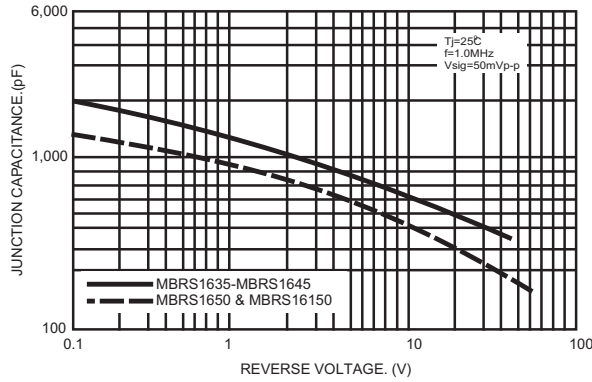

FIG.6- TYPICAL TRANSIENT THERMAL CHARACTERISTICS

