

International
IR Rectifier

MBR20...CT
 MBRB20...CT
 MBR20...CT-1

SCHOTTKY RECTIFIER

20 Amp

Major Ratings and Characteristics



Characteristics	Values	Units
$I_{F(AV)}$ Rectangular waveform (Per Device)	20	A
I_{FRM} @ $T_C = 133^\circ\text{C}$ (Per Leg)	20	A
V_{RRM}	80/90/100	V
I_{FSM} @ $t_p = 5\mu\text{s}$ sine	850	A
V_F @ 10 Apk, $T_J = 125^\circ\text{C}$	0.70	V
T_J range	-65 to 150	$^\circ\text{C}$

Description/ Features

This center tap Schottky rectifier has been optimized for low reverse leakage at high temperature. The proprietary barrier technology allows for reliable operation up to 150°C junction temperature. Typical applications are in switching power supplies, converters, free-wheeling diodes, and reverse battery protection.

- 150°C T_J operation
- Center tap TO-220, D²Pak and TO-262 packages
- Low forward voltage drop
- High purity, high temperature epoxy encapsulation for enhanced mechanical strength and moisture resistance
- High frequency operation
- Guard ring for enhanced ruggedness and long term reliability

Case Styles

MBR20...CT	MBRB20...CT	MBR20...CT-1
		
TO-220	D ² PAK	TO-262

Voltage Ratings

Parameters	MBR2080CT MBRB2080CT MBR2080CT-1	MBR2090CT MBRB2090CT MBR2090CT-1	MBR20100CT MBRB20100CT MBR20100CT-1
V _R Max. DC Reverse Voltage (V)	80	90	100
V _{RWM} Max. Working Peak Reverse Voltage (V)			

Absolute Maximum Ratings

Parameters	Values	Units	Conditions
I _{F(AV)} Max. Average Forward Current (Per Leg) (Per Device)	10	A	@ T _C = 133°C, (Rated V _R)
	20		
I _{FRM} Peak Repetitive Forward Current (Per Leg)	20	A	Rated V _F , square wave, 20kHz T _C = 133°C
I _{FSM} Non Repetitive Peak Surge Current	850	A	5µs Sine or 3µs Rect. pulse Following any rated load condition and with rated V _{RRM} applied Surge applied at rated load conditions halfwave, single phase, 60Hz
	150		
I _{RRM} Peak Repetitive Reverse Surge Current	0.5	A	2.0 µsec 1.0KHz
E _{AS} Non-Repetitive Avalanche Energy (Per Leg)	24	mJ	T _J = 25 °C, I _{AS} = 2 Amps, L = 12 mH

Electrical Specifications

Parameters	Values	Units	Conditions
V _{FM} Max. Forward Voltage Drop (1)	0.80	V	@ 10A
	0.95	V	@ 20A
	0.70	V	@ 10A
	0.85	V	@ 20A
I _{RM} Max. Instantaneous Reverse Current (1)	0.10	mA	T _J = 25 °C
	6	mA	T _J = 125 °C
V _{F(TO)} Threshold Voltage	0.433	V	T _J = T _J max.
r _t Forward Slope Resistance	15.8	mΩ	
C _T Max. Junction Capacitance	400	pF	V _R = 5V _{DC} , (test signal range 100Khz to 1Mhz) 25°C
L _S Typical Series Inductance	8.0	nH	Measured from top of terminal to mounting plane
dv/dt Max. Voltage Rate of Change (Rated V _R)	10,000	V/µs	

(1) Pulse Width < 300µs, Duty Cycle <2%

Thermal-Mechanical Specifications

Parameters	Values	Units	Conditions
T _J Max. Junction Temperature Range	-65 to 150	°C	
T _{stg} Max. Storage Temperature Range	-65 to 175	°C	
R _{thJC} Max. Thermal Resistance Junction to Case (Per Leg)	2.0	°C/W	DC operation
R _{thCS} Typical Thermal Resistance Case to Heatsink	0.50	°C/W	Mounting surface, smooth and greased Only for TO-220
R _{thJA} Max. Thermal Resistance Junction to Ambient	50	°C/W	DC operation For D ² Pak and TO-262
wt Approximate Weight	2(0.07)	g(oz.)	
T Mounting Torque	Min.	6(5)	Non-lubricated threads
	Max.	12(10)	

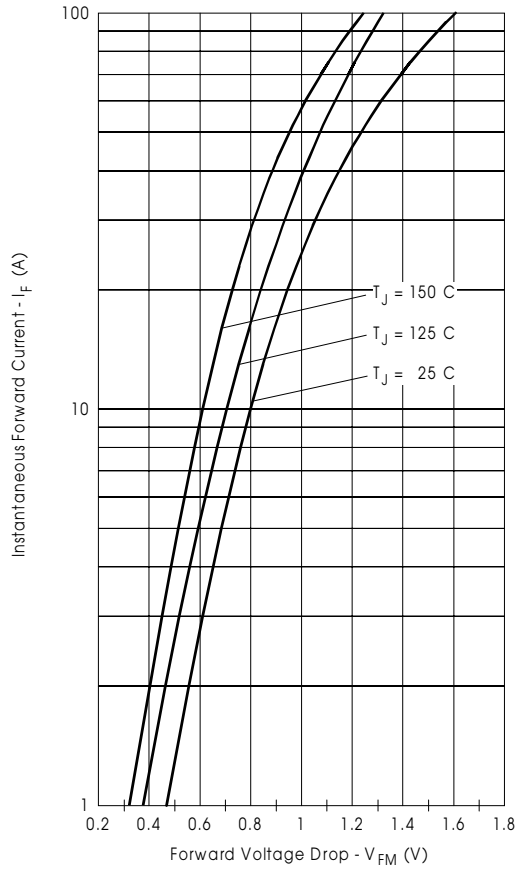

Fig. 1 - Max. Forward Voltage Drop Characteristics (Per Leg)

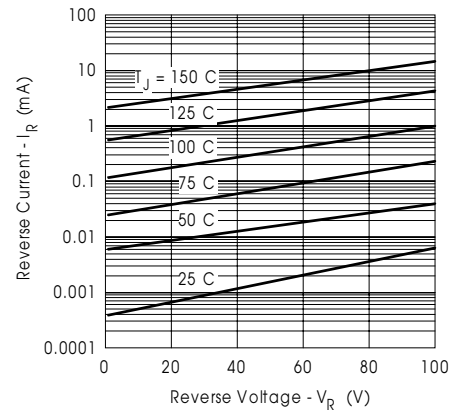

Fig. 2 - Typical Values Of Reverse Current Vs. Reverse Voltage (Per Leg)

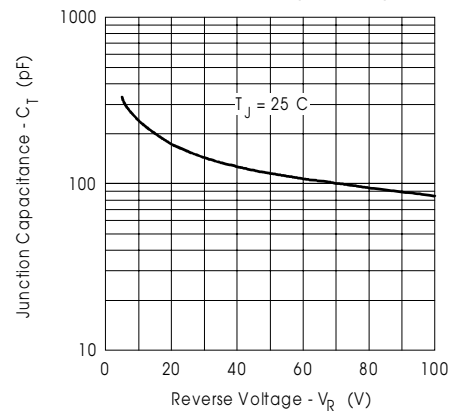

Fig. 3 - Typical Junction Capacitance Vs. Reverse Voltage (Per Leg)

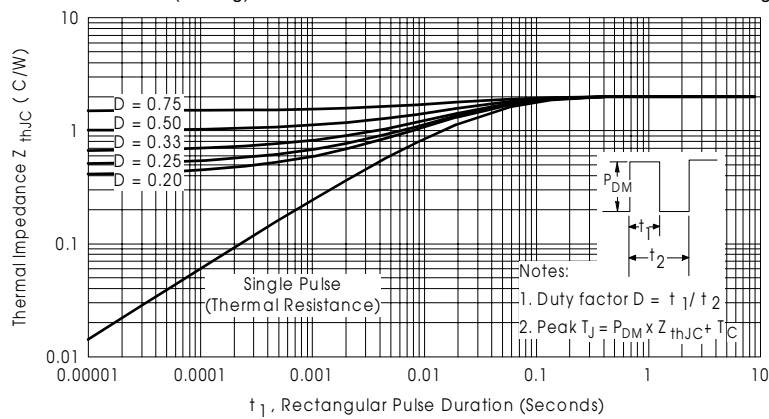

Fig. 4 - Max. Thermal Impedance Z_{thJC} Characteristics (Per Leg)

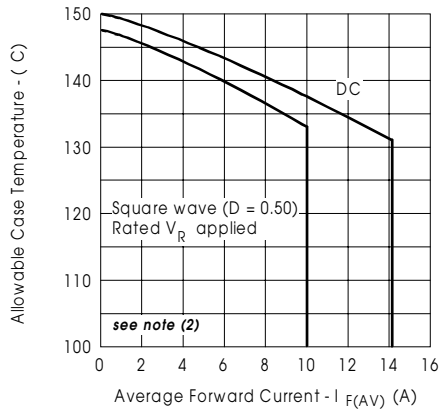

Fig. 5 - Max. Allowable Case Temperature Vs. Average Forward Current (Per Leg)

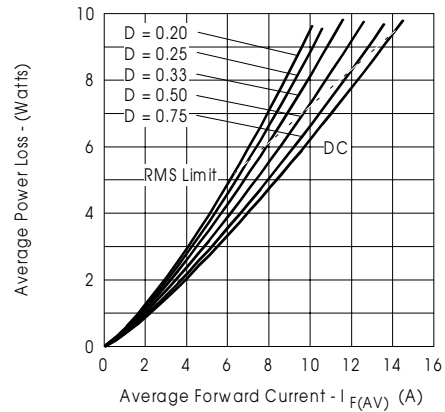

Fig. 6 - Forward Power Loss Characteristics (Per Leg)

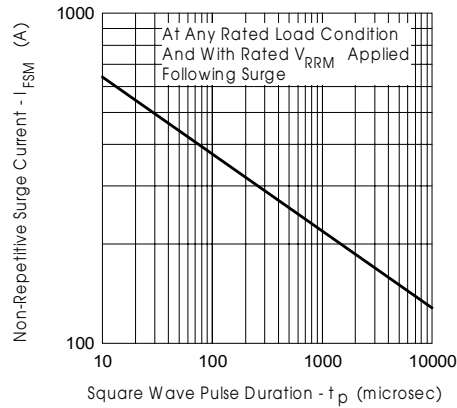

Fig. 7 - Max. Non-Repetitive Surge Current (Per Leg)

(2) Formula used: $T_C = T_J - (Pd + Pd_{REV}) \times R_{thJC}$

Pd = Forward Power Loss = $I_{F(AV)} \times V_{FM} @ (I_{F(AV)}/D)$ (see Fig. 6);

Pd_{REV} = Inverse Power Loss = $V_{R1} \times I_R (1-D)$; $I_R @ V_{R1}$ = rated V_R

Outline Table

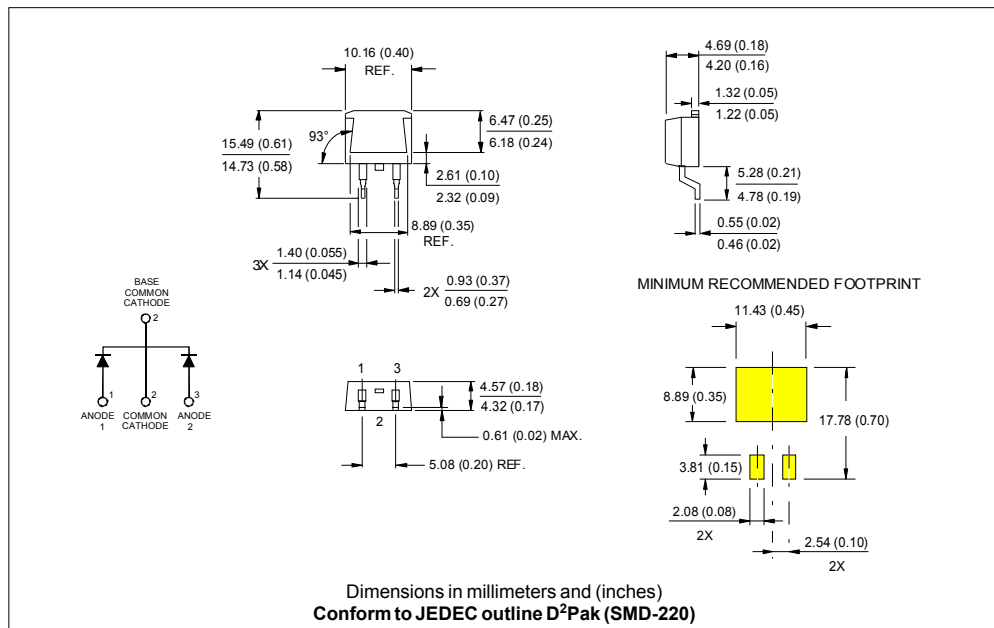
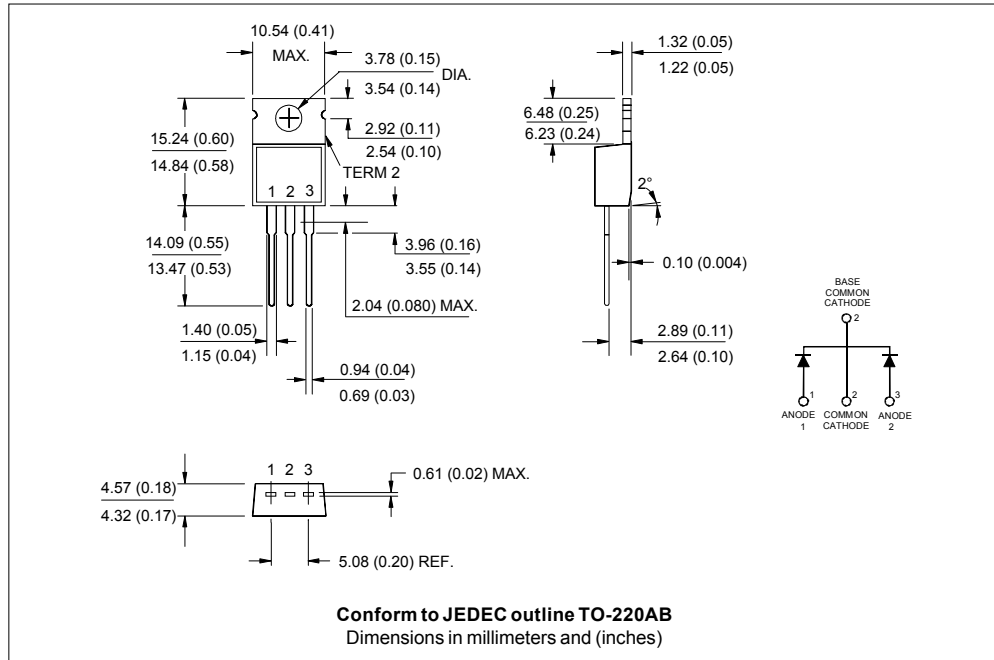

MBR20...CT, MBRB20...CT, MBR20...CT-1

Bulletin PD-2.321 rev.1 08/02

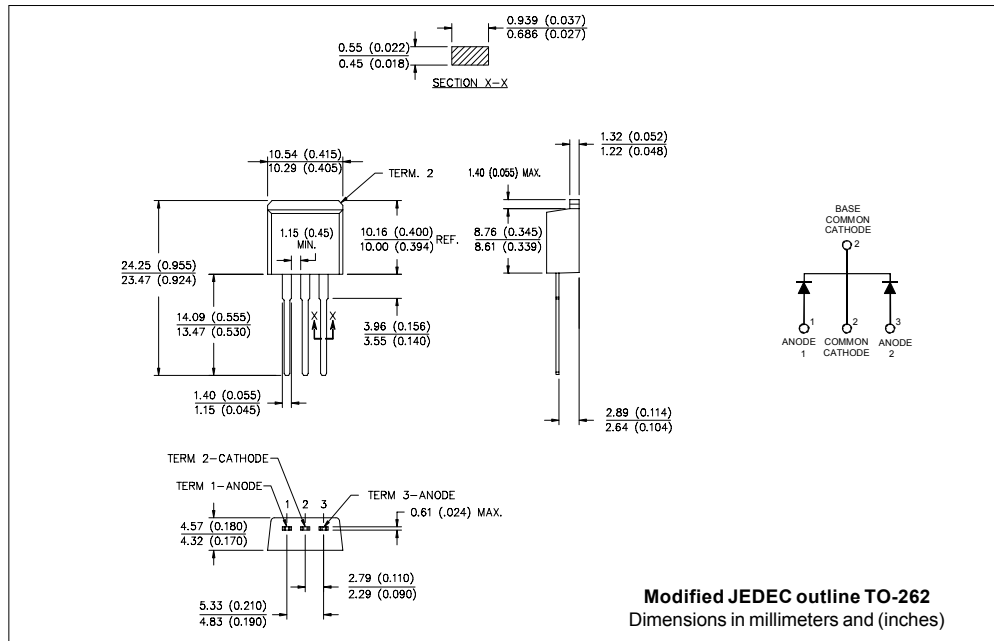

Tape & Reel Information

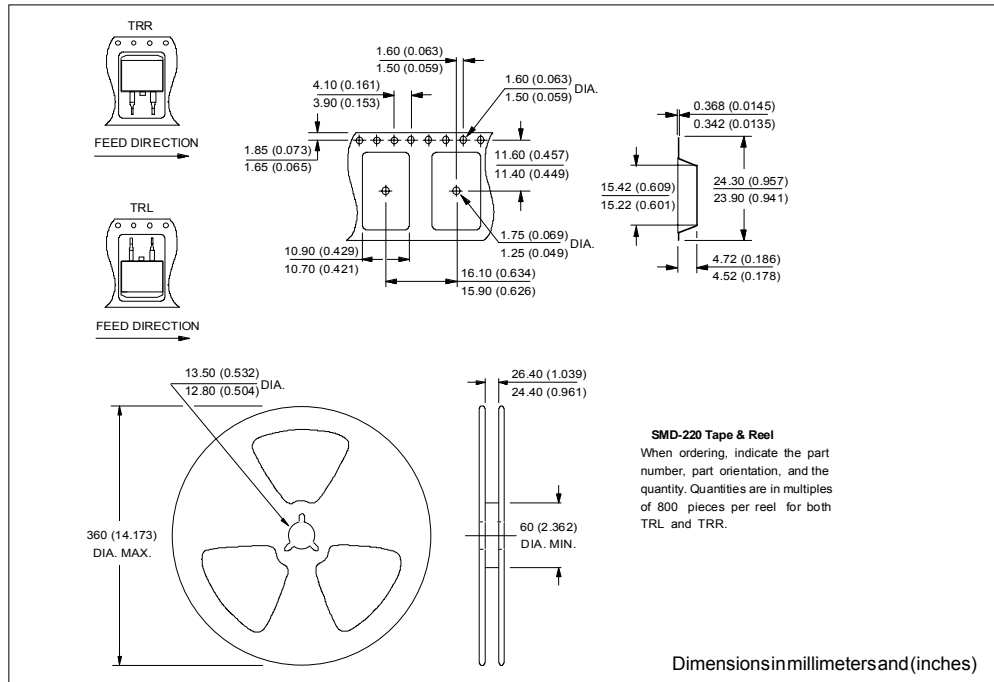

Marking Information

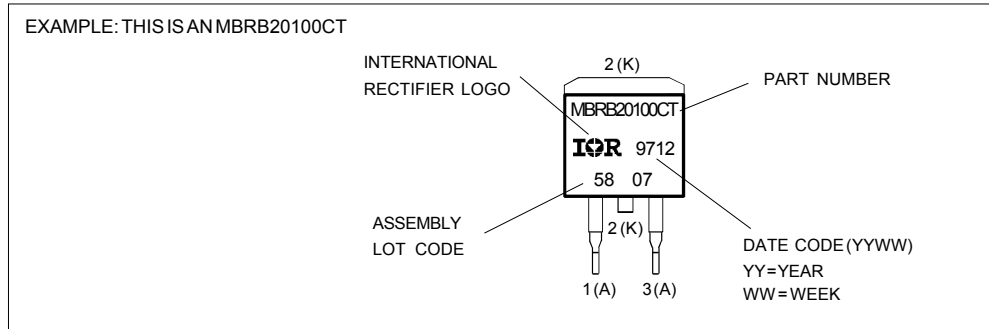

Ordering Information Table

Device Code	
1	MBR
2	B
3	20
4	100
5	CT
6	-1

1	-	Essential Part Number
2	-	B = Surface Mount None = TO-220
3	-	Current Rating
4	-	Voltage code: Code = V_{RRM}
5	-	CT = Essential Part Number
6	-	-1 = TO-262 None = TO-220

080 = 80V
 090 = 90V
 100 = 100V

Data and specifications subject to change without notice.
 This product has been designed and qualified for Industrial Level.
 Qualification Standards can be found on IR's Web site.

This datasheet has been download from:

www.datasheetcatalog.com

Datasheets for electronics components.