



**MBR15..CT**  
**MBRB15..CT**  
**MBR15..CT-1**

**SCHOTTKY RECTIFIER**

**15 Amp**

$I_{F(AV)} = 15\text{Amp}$   
 $V_R = 35 - 45\text{V}$





**Major Ratings and Characteristics**

Characteristics	Values	Units
$I_{F(AV)}$ Rectangular waveform	15	A
$V_{RRM}$	35-45	V
$I_{FSM}$ @ tp = 5 $\mu$ s sine	690	A
$V_F$ @ 7.5 Apk, $T_J = 125^\circ\text{C}$	0.57	V
$T_J$	-65 to 150	$^\circ\text{C}$

**Description/ Features**

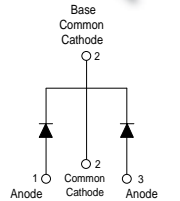
The MBR15..CT center tap Schottky rectifier has been optimized for low reverse leakage at high temperature. The proprietary barrier technology allows for reliable operation up to 150° C junction temperature. Typical applications are in switching power supplies, converters, free-wheeling diodes, and reverse battery protection.

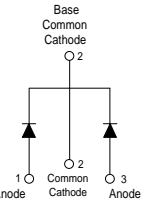
- 150° C  $T_J$  operation
- Center tap TO-220 package
- Low forward voltage drop
- High purity, high temperature epoxy encapsulation for enhanced mechanical strength and moisture resistance
- High frequency operation
- Guard ring for enhanced ruggedness and long term reliability

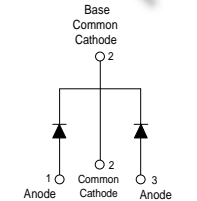
<b>Case Styles</b>		
<p><b>MBR15..CT</b></p>  <p>Base Common Cathode</p> <p>2</p>  <p>1 Anode    2 Common Cathode    3 Anode</p> <p><b>TO-220</b></p>	<p><b>MBRB15..CT</b></p>  <p>Base Common Cathode</p> <p>2</p>  <p>1 Anode    2 Common Cathode    3 Anode</p> <p><b>D<sup>2</sup>PAK</b></p>	<p><b>MBR15..CT-1</b></p>  <p>Base Common Cathode</p> <p>2</p>  <p>1 Anode    2 Common Cathode    3 Anode</p> <p><b>TO-262</b></p>

Voltage Ratings

Parameters	MBR1535CT MBRB1535CT MBR1535CT-1	MBR1545CT MBRB1545CT MBR1545CT-1
V <sub>R</sub> Max. DC Reverse Voltage (V)	35	45
V <sub>RWM</sub> Max. Working Peak Reverse Voltage (V)		

Absolute Maximum Ratings

Parameters	Value	Units	Conditions
I <sub>F(AV)</sub> Max. Aver. Forward Current (Per Leg) (Per Device)	7.5 15	A	@ T <sub>C</sub> = 131 °C (Rated V <sub>R</sub> )
I <sub>FSM</sub> Max. Peak One Cycle Non Repetitive Surge	690 150	A	5µs Sine or 3µs Rect. pulse Surge applied at rated load condition halfwave single phase 60Hz Following any rated load condition and with rated V <sub>RRM</sub> applied
E <sub>AS</sub> Non-Repetitive Avalanche Energy	7	mJ	(Per Leg) T <sub>J</sub> = 25 °C, I <sub>AS</sub> = 2 Amps, L = 3.5 mH
I <sub>AR</sub> Repetitive Avalanche Current (Per Leg)	2	A	Current decaying linearly to zero in 1 µsec Frequency limited by T <sub>J</sub> max. V <sub>A</sub> = 1.5 x V <sub>R</sub> typical

Electrical Specifications

Parameters	Value	Units	Conditions
V <sub>FM</sub> Max. Forward Voltage Drop (1)	0.84 0.57 0.72	V	@ 15A T <sub>J</sub> = 25 °C @ 7.5A T <sub>J</sub> = 125 °C @ 15A
I <sub>RM</sub> Max. Instantaneous Reverse Current (1)	0.1 15	mA	T <sub>J</sub> = 25 °C T <sub>J</sub> = 125 °C Rated DC voltage
C <sub>T</sub> Max. Junction Capacitance	400	pF	V <sub>R</sub> = 5V <sub>DC</sub> (test signal range 100Khz to 1Mhz) 25 °C
L <sub>S</sub> Typical Series Inductance	8.0	nH	Measured from top of terminal to mounting plane
dv/dt Max. Voltage Rate of Change (Rated V <sub>R</sub> )	10000	V/ µs	

(1) Pulse Width < 300µs, Duty Cycle <2%

Thermal-Mechanical Specifications

Parameters	Value	Units	Conditions
T <sub>J</sub> Max. Junction Temperature Range	-65 to 150	°C	
T <sub>stg</sub> Max. Storage Temperature Range	-65 to 175	°C	
R <sub>thJC</sub> Max. Thermal Resistance Junction to Case (Per Leg)	3.0	°C/W	DC operation
R <sub>thCS</sub> Typical Thermal Resistance, Case to Heatsink	0.50	°C/W	Mounting surface, smooth and greased
R <sub>thJA</sub> Max. Thermal Resistance Junction	60	°C/W	DC operation
wt Approximate Weight	2 (0.07)	g (oz.)	
T Mounting Torque	Min. 6 (5) Max. 12 (10)	Kg-cm (lbf-in)	
Device Marking	MBR15..CT MBRB15..CT MBR15..CT-1		Case style TO-220 Case style D <sup>2</sup> Pak Case style TO-262

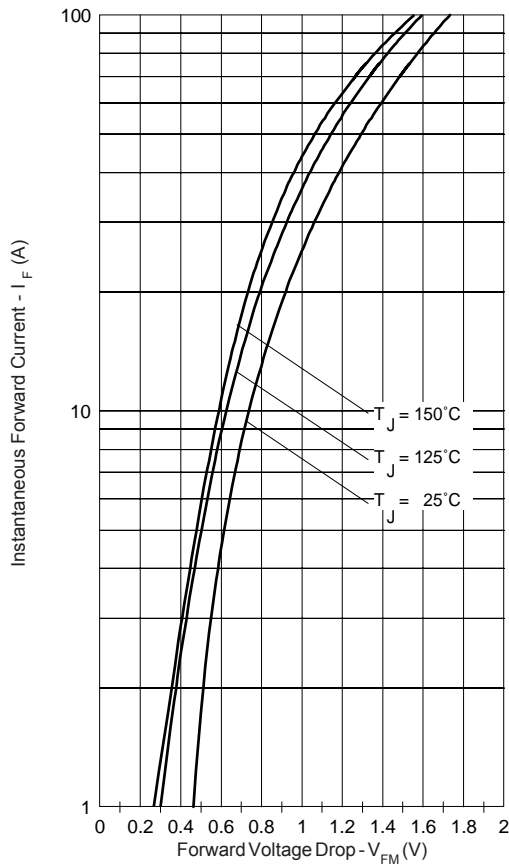

Fig. 1 - Max. Forward Voltage Drop Characteristics (Per Leg)

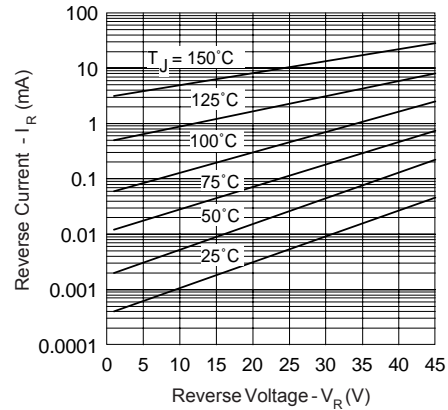

Fig. 2 - Typical Values Of Reverse Current Vs. Reverse Voltage (Per Leg)

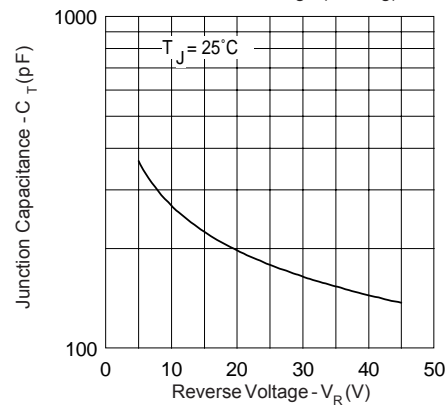

Fig. 3 - Typical Junction Capacitance Vs. Reverse Voltage (Per Leg)

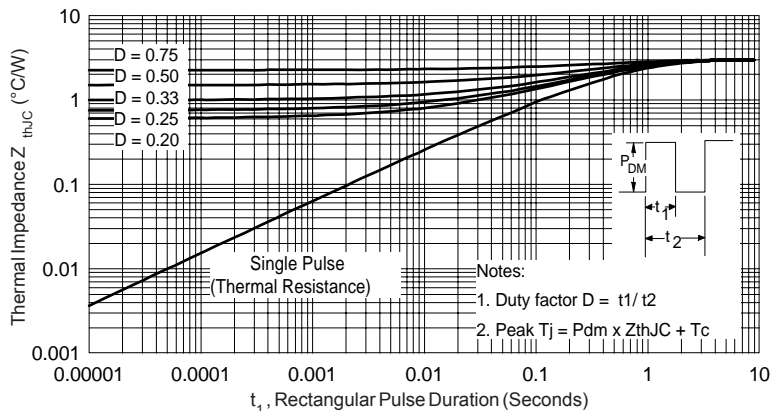

Fig. 4 - Max. Thermal Impedance  $Z_{thJC}$  Characteristics (Per Leg)

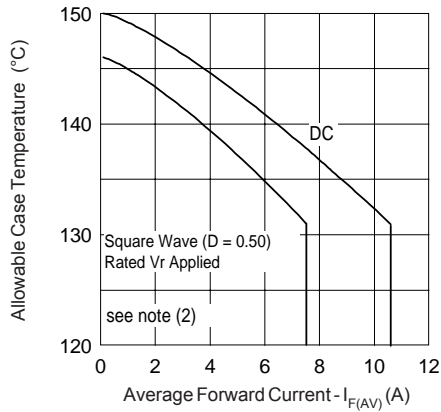

Fig. 5 - Max. Allowable Case Temperature Vs. Average Forward Current

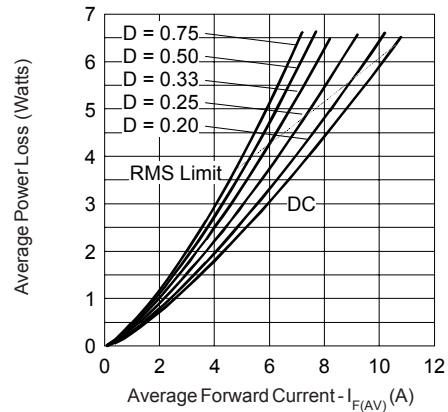

Fig. 6 - Forward Power Loss Characteristics

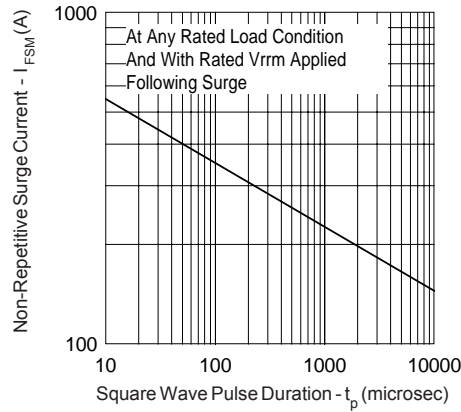
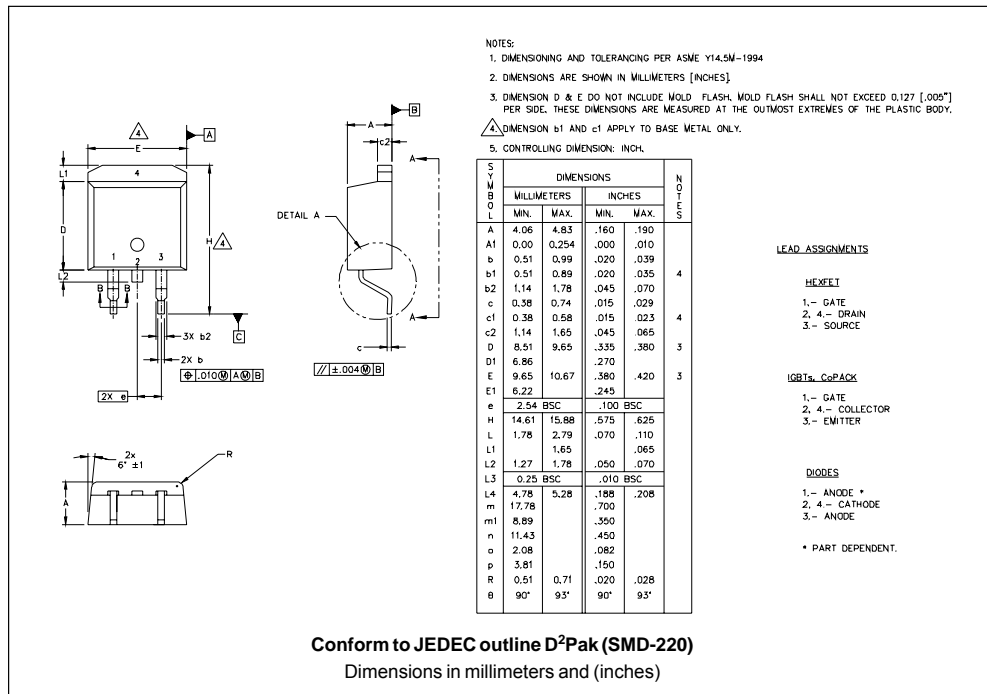
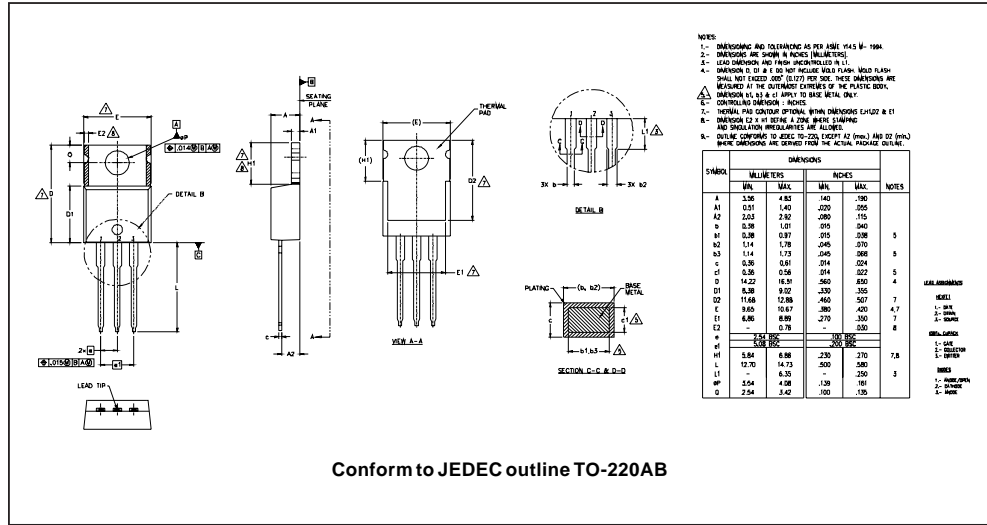

Fig. 7 - Max. Non-Repetitive Surge Current (Per Leg)

(2) Formula used:  $T_c = T_j - (Pd + Pd_{REV}) \times R_{thJC}$ ;  
 $Pd = \text{Forward Power Loss} = I_{F(AV)} \times V_{FM} @ (I_{F(AV)} / D)$  (see Fig. 6);  
 $Pd_{REV} = \text{Inverse Power Loss} = V_{R1} \times I_R (1 - D)$ ;  $I_R @ V_{R1} = \text{rated } V_R$

Outline Table



Outline Table

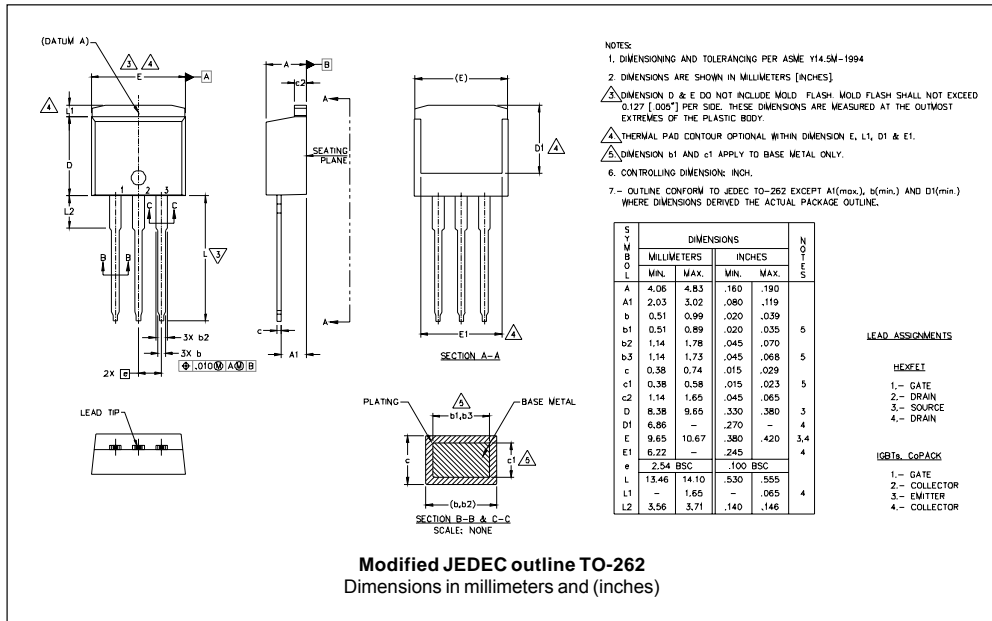

Tape & Reel Information

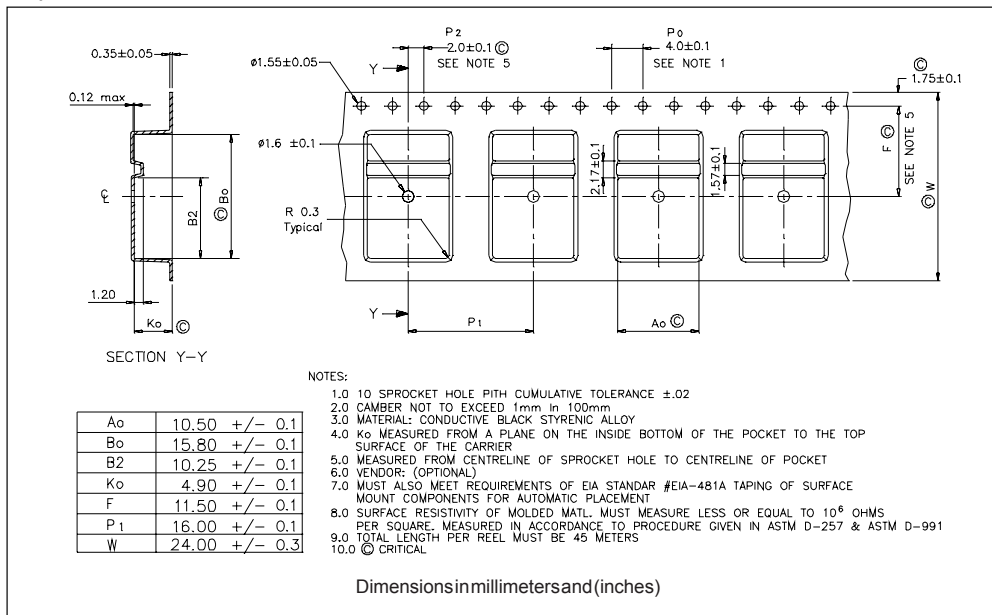

Part Marking Information

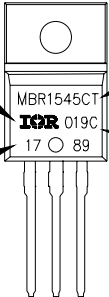
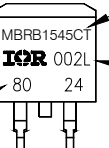
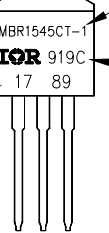
<p>TO-220</p>	<p>EXAMPLE: THIS IS A MBR1545CT            LOT CODE 1789            ASSEMBLED ON WW 19, 2000            IN THE ASSEMBLY LINE "C"</p>	 <p>INTERNATIONAL RECTIFIER LOGO</p> <p>ASSEMBLY LOT CODE</p> <p>PART NUMBER</p> <p>DATE CODE</p> <p>YEAR 0 = 2000            WEEK 19            LINE C</p>
<p>D<sup>2</sup>PAK</p>	<p>EXAMPLE: THIS IS A MBRB1545CT            LOT CODE 8024            ASSEMBLED ON WW 02, 2000            IN THE ASSEMBLY LINE "L"</p>	 <p>INTERNATIONAL RECTIFIER LOGO</p> <p>ASSEMBLY LOT CODE</p> <p>PART NUMBER</p> <p>DATE CODE</p> <p>YEAR 0 = 2000            WEEK 02            LINE L</p>
<p>TO-262</p>	<p>EXAMPLE: THIS IS A MBR1545CT-1            LOT CODE 1789            ASSEMBLED ON WW 19, 1999            IN THE ASSEMBLY LINE "C"</p>	 <p>INTERNATIONAL RECTIFIER LOGO</p> <p>ASSEMBLY LOT CODE</p> <p>PART NUMBER</p> <p>DATE CODE</p> <p>YEAR 9 = 1999            WEEK 19            LINE C</p>

```

MBR1545CT
*****
*      This model has been developed by      *
*      Wizard SPICE MODEL GENERATOR (1999) *
*      (International Rectifier Corporation) *
*      contains Proprietary Information     *
*****
* SPICE Model Diode is composed by a      *
* simple diode plus paralled VCG2T        *
*****
.SUBCKT MBR1545 ANO CAT
D1 ANO 1 DMOD (0.03191)
*Define diode model
.MODEL DMOD D(IS=9.72464638473799E-05A,N=1.30648926537753,BV=52V,
+ IBV=0.195508065728349A,RS= 0.000727548,CJO=1.94829876431799E-08,
+ VJ=2.27282978121533,XTI=2, EG=0.854458710837653)
*****
*Implementation of VCG2T
VX 1 2 DC 0V
R1 2 CAT TRES 1E-6
.MODEL TRES RES(R=1,TC1=27.6281424524011)
GP1 ANO CAT VALUE={-ABS(I(VX))*(EXP((( -5.219758E-03/27.62814)*(V(2,CAT)*1E6)/
(I(VX)+1E-6)-1))+1)*7.000165E-02*ABS(V(ANO,CAT)))-1}
*****
.ENDS MBR1545

Thermal Model Subcircuit
.SUBCKT MBR1545 5 1

CTHERM1  5  4  1.05E+00
CTHERM2  4  3  4.44E+00
CTHERM3  3  2  1.16E+01
CTHERM4  2  1  6.12E+01

RTHERM1  5  4  1.33E+00
RTHERM2  4  3  1.19E+00
RTHERM1  3  2  3.81E-01
RTHERM1  2  1  9.54E-02

.ENDS MBR1545
    
```



Ordering Information Table

Device Code	
	<div style="display: flex; justify-content: space-around; align-items: center;"> <div style="border: 1px solid black; padding: 2px 5px; margin: 2px;">MBR</div> <div style="border: 1px solid black; padding: 2px 5px; margin: 2px;">B</div> <div style="border: 1px solid black; padding: 2px 5px; margin: 2px;">15</div> <div style="border: 1px solid black; padding: 2px 5px; margin: 2px;">45</div> <div style="border: 1px solid black; padding: 2px 5px; margin: 2px;">CT</div> <div style="border: 1px solid black; padding: 2px 5px; margin: 2px;">-1</div> <div style="border: 1px solid black; padding: 2px 5px; margin: 2px;">TRL</div> <div style="border: 1px solid black; padding: 2px 5px; margin: 2px;">-</div> </div>
	<div style="display: flex; justify-content: space-around; align-items: center;"> <div style="border: 1px solid black; border-radius: 50%; width: 20px; height: 20px; display: flex; align-items: center; justify-content: center;">1</div> <div style="border: 1px solid black; border-radius: 50%; width: 20px; height: 20px; display: flex; align-items: center; justify-content: center;">2</div> <div style="border: 1px solid black; border-radius: 50%; width: 20px; height: 20px; display: flex; align-items: center; justify-content: center;">3</div> <div style="border: 1px solid black; border-radius: 50%; width: 20px; height: 20px; display: flex; align-items: center; justify-content: center;">4</div> <div style="border: 1px solid black; border-radius: 50%; width: 20px; height: 20px; display: flex; align-items: center; justify-content: center;">5</div> <div style="border: 1px solid black; border-radius: 50%; width: 20px; height: 20px; display: flex; align-items: center; justify-content: center;">6</div> <div style="border: 1px solid black; border-radius: 50%; width: 20px; height: 20px; display: flex; align-items: center; justify-content: center;">7</div> <div style="border: 1px solid black; border-radius: 50%; width: 20px; height: 20px; display: flex; align-items: center; justify-content: center;">8</div> </div>
<b>1</b>	- Essential Part Number
<b>2</b>	- <ul style="list-style-type: none"> <li>• B = D<sup>2</sup>Pak <b>6</b> none</li> <li>• none = TO-220 <b>6</b> none</li> <li>• none = TO-262 <b>6</b> = -1</li> </ul>
<b>3</b>	- Current Rating (15 = 15A)
<b>4</b>	- Voltage Ratings <span style="float: right; border: 1px solid black; padding: 2px;">35 = 35V 45 = 45V</span>
<b>5</b>	- CT = Essential Part Number
<b>6</b>	- <ul style="list-style-type: none"> <li>• none = TO-220 <b>2</b> none</li> <li>• none = D<sup>2</sup>Pak <b>2</b> = B</li> <li>• -1 = TO-262 <b>2</b> none</li> </ul>
<b>7</b>	- <ul style="list-style-type: none"> <li>• none = Tube (50 pieces)</li> <li>• TRL = Tape &amp; Reel (Left Oriented - for D<sup>2</sup>Pak only)</li> <li>• TRR = Tape &amp; Reel (Right Oriented - for D<sup>2</sup>Pak only)</li> </ul>
<b>8</b>	- <ul style="list-style-type: none"> <li>• none = Standard Production</li> <li>• PbF = Lead-Free (for TO-220TO-262 and D<sup>2</sup>Pak tube)</li> <li>• P = Lead-Free (for D<sup>2</sup>Pak TRR and TRL)</li> </ul>

Data and specifications subject to change without notice.  
This product has been designed and qualified for Industrial Level.  
Qualification Standards can be found on IR's Web site.