

CR Magnetics **CR8400** Series of Wire Lead Current Transformers are available in a wide range of sizes and materials to meet any AC current sensing needs. Our **General Purpose** designs are made from the highest quality silicon steel cores available, and meet most of the common AC current measurement needs. Our **Revenue Grade** CTs (-N) are made from a nickel alloy core which provides the most linear response over temperature and current level. A line of **Ground Fault** (-G) CTs for measuring low AC currents including electrical shields. The **High Frequency** (-F) products are designed for high frequency applications such as high frequency power supplies and motor drives.

CR8400 SERIES



Applications

Motor Load Measurement
Power Meters
High Frequency Current Sensing
Ground Fault Sensing

Features

High Ratio
Standard Footprints

Specifications

Maximum Continuous Primary Current 4 X I_r
Storage Temp. -45°C thru +85°C
Operating Temp. General Purpose & Nickel -40°C thru +85°C
Operating Temp. High Frequency -40°C thru +65°C

Regulatory Agencies

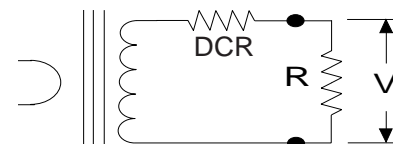

$$V = \frac{I \times R}{T_e} \quad V_L = V_{max} - \left[\frac{I \times DCR}{T_e} \right]$$

For best linearity, choose R such that $V < 0.8 V_L$

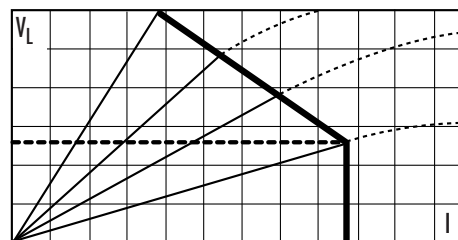

GENERAL PURPOSE CURRENT TRANSFORMERS

Part Number	I _r	V _{max} RMS	T _e (typ.)	DCR Ω	Frequency
CR8401-1000	10	1.5	1009	49	20 - 1 KHz
CR8410-1000	20	2.1	1012	41	20 - 1 KHz
CR8420-1000	50	3.8	1018	22	20 - 1 KHz
CR8448-2000	50	10.2	2046	106	20 - 1 KHz
CR8449-1000	50	6.8	1016	35	20 - 1 KHz
CR8449-2000	75	12.8	2046	83	20 - 1 KHz
CR8450-1000	100	10.7	1021	21	20 - 1 KHz
CR8450-2000	200	14.6	2037	73	20 - 1 KHz

REVENUE GRADE CURRENT TRANSFORMERS

Part Number	I _r	V _{max} RMS	T _e (typ.)	DCR Ω	Frequency
CR8448-2500-N	40	2.3	2510	134	20 - 1 KHz
CR8449-2500-N	50	2.4	1009	187	20 - 1 KHz
CR8450-2500-N	75	4.8	2512	160	20 - 1 KHz
CR8459-2000-N	200	7.2	2011	74	20 - 1 KHz

GROUND FAULT CURRENT TRANSFORMERS

Part Number	I _r	V _{max} RMS	T _e (typ.)	DCR Ω	Frequency
CR8401-1000-G	4	0.4	1005	49	20 - 1 KHz
CR8410-1000-G	7	1.1	1007	38	20 - 1 KHz
CR8420-1000-G	20	1.7	1011	44	20 - 1 KHz

HIGH FREQUENCY CURRENT TRANSFORMERS

Part Number	I _r	V _{max} RMS	T _e (typ.)	DCR Ω	Frequency
CR8448-2000-F	50	4.1	2015	90	20 - 200 KHz
CR8449-2000-F	75	7.4	2017	109	20 - 200 KHz
CR8450-2000-F	100	10.3	2020	63	20 - 200 KHz

I_r = Maximum Input Current to be linearly sensed V_{max} = Maximum Voltage (Saturation) CT will develop

T_e = Effective turns ratio including losses (All Specifications tested at 60 Hz)

PACKAGE DIMENSIONS AND OUTLINE (mm/in)

Part Number Prefix	A					B					
	min	max	max	max	Typ	min	max	max	max	Typ	
CR8401	6.99	17.53	22.35	8.26	75.08	CR8449	9.14	26.0	31.8	17.0	100
	.275	.690	.880	.325	2.275		.354	1.02	1.25	.67	3.94
CR8410	9.0	22	27.8	8.20	73	CR8450	3.08	36.83	43.18	13.97	88.9
	.35	.87	1.09	.323	2.87		.515	1.45	1.70	.55	3.50
CR8420	15.0	30.0	36.0	9.2	100	CR8459	19	48	60	17.5	200
	.59	1.18	1.41	.36	3.94		.75	1.89	2.36	.67	7.88
CR8448	7.11	23.42	29.46	11.05	100						
	.280	.922	1.16	.435	3.94						

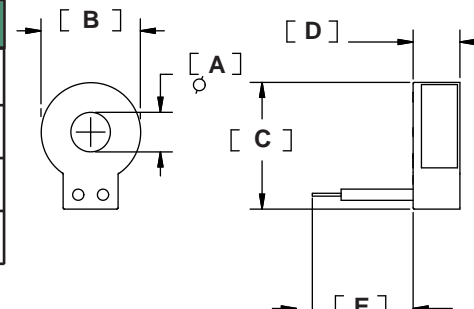

CR Magnetics, Inc. 3500 Scarlet Oak Blvd. St. Louis MO USA 63122 V: 636-343-8518 F: 636-343-5119

Web: <http://www.crmagnetics.com>

E-mail: sales@crmagnetics.com