



AlfaMag Electronics

CT Series • Current Sensor for 50/60 Hz

Part Number	CT 1150
Customer	
Product Type	Current transformer

SCHEMATIC:

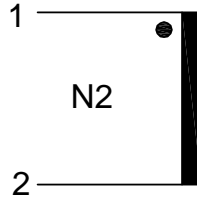

ELECTRICAL SPECIFICATION:

- Rated input current : 150Amps
- Primary to Secondary isolation : 2500VAC
- Operating frequency : 50 / 60Hz
- Turns ratio : 1:1000
- DCR : 11.00Ω
- I_o @ V_{rms} = 16.6V : 1820μArms
- Ratio correction factor (RCF*) : 1.002 @10% (Multiply current reading by this factor to compensate for transformer losses)

Volt/Amp at rated I _p for different loads			
100Ω	500Ω	2000Ω	5000Ω
0.10	0.37	0.50	0.55

LOAD TEST DETAILS:

Rated I_p=150A
 R_L=100Ω/2.25W
 U_s=15.0V

MARKING INFORMATION:

ALFAMAG
 ELECTRONICS
 YY/WW CT1150

Trafo Weight:

0.150Kg/pc

MECHANICAL DIMENSIONS:

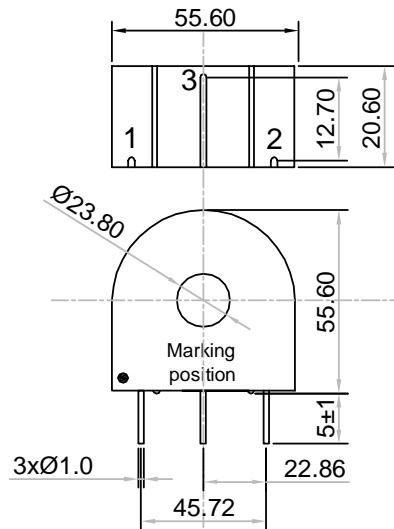

All dimensions are in mm
 Linear dimensional tolerance ±0.2mm

AlfaMag Electronics * 10830 Kinghurst Drive * Houston, TX 77099
 Phone: 832-775-1318 * Fax: 832-775-1317 * email: support@alfamag.com
 Toll Free: 800-413-6693 * www.alfamag.com