



AlfaMag Electronics

CT Series • Current Sensor for 50/60 Hz

Part Number	CT 1010
Customer	
Product Type	Current Transformer

**SCHEMATIC:**

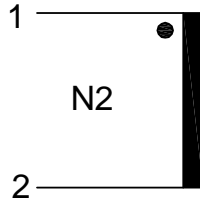

**ELECTRICAL SPECIFICATION:**

- Rated input current : 10Amps
- Primary to Secondary isolation : 2500VAC
- Operating frequency : 50 / 60Hz
- Turns ratio : 1:1000
- DCR : 41.80Ω
- $I_o @ V_{rms} = 1.32V$  : 386μArms
- Ratio correction factor (RCF\*) : 1.01 @10% ( Multiply current reading by this factor to compensate for transformer losses)

Volt/Amp at rated $I_p$ for different loads			
100Ω	500Ω	2000Ω	5000Ω
0.10	0.45	1.10	1.42

**LOAD TEST DETAILS:**

Rated  $I_p=10A$   
 $R_L=100\Omega/0.01W$   
 $U_s=1V$

**MARKING INFORMATION:**

ALFAMAG  
 ELECTRONICS  
 YY/WW CT1010

**Trafo Weight:**

0.017Kg/pc

**MECHANICAL DIMENSIONS:**

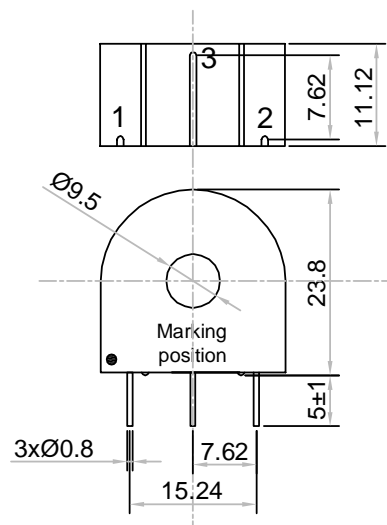

All dimensions are in mm  
 Linear dimensional tolerance  $\pm 0.2mm$

AlfaMag Electronics \* 10830 Kinghurst Drive \* Houston, TX 77099  
 Phone: 832-775-1318 \* Fax: 832-775-1317 \* email: [support@alfamag.com](mailto:support@alfamag.com)  
 Toll Free: 800-413-6693 \* [www.alfamag.com](http://www.alfamag.com)