



AlfaMag Electronics

CT Series • Current Sensor for 50/60 Hz

Part Number	CT 1015
Customer	
Product Type	Current transformer

**SCHEMATIC:**

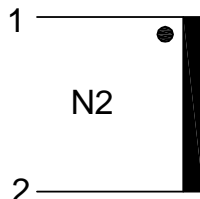

**ELECTRICAL SPECIFICATION:**

- Rated input current : 15Amps
- Primary to Secondary isolation : 2500VAC
- Operating frequency : 50 / 60Hz
- Turns ratio : 1:1000
- DCR : 41.80Ω
- I<sub>o</sub> @ V<sub>rms</sub> = 1.99V : 513μArms
- Ratio correction factor (RCF\*) : 1.01 @ 10% ( Multiply current reading by this factor to compensate for transformer losses)

Volt/Amp at rated I <sub>p</sub> for different loads			
100Ω	500Ω	2000Ω	5000Ω
0.10	0.45	0.90	1.12

**LOAD TEST DETAILS:**

Rated I<sub>p</sub>=15A  
 R<sub>L</sub>=100Ω/0.023W  
 U<sub>s</sub>=1.5V

**MARKING INFORMATION:**

ALFAMAG  
 ELECTRONICS  
 YY/WW CT1015

**Trafo Weight:**

0.017Kg/pc

**MECHANICAL DIMENSIONS:**

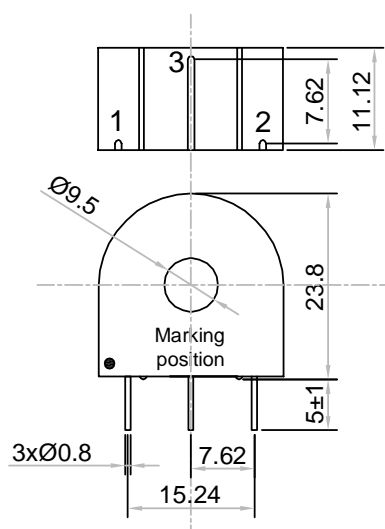

All dimensions are in mm  
 Linear dimensional tolerance ±0.2mm

AlfaMag Electronics \* 10830 Kinghurst Drive \* Houston, TX 77099  
 Phone: 832-775-1318 \* Fax: 832-775-1317 \* email: [support@alfamag.com](mailto:support@alfamag.com)  
 Toll Free: 800-413-6693 \* [www.alfamag.com](http://www.alfamag.com)