

**FineAdjust
Applicator**

**Application Tooling
Specification Sheet**

Order No. 63900-2900

FEATURES

- Quick punch removal with the push of a button for fast and easy tooling change
- Applicator designed to industry standard mounting and shut height 135.80mm (5.346")
- Quick set-up time; plus the crimp height, track and feed adjustments can be set without removing the applicator from the press
- Fine adjustment allows users to achieve target with little effort by adjusting in increments of .015mm (.0006") for conductor crimp height and .063mm (.0025") for insulation height
- Independent adjustment rings allow users to quickly adjust the conductor or insulation crimp height without affecting each other
- Directly adapts to most automatic wire processing machines

SCOPE

Products: Mini-Fit Jr.™, Mini-Fit HCS™, and Mini-Fit Plus HCS™ Crimp Terminal 18-24 AWG with smaller insulation OD's.

| Terminal Series No. | Terminal Order No. | | Wire Size | | Insulation Diameter | | | | Strip Length | |
|---------------------|--------------------|------------|-----------|-----------|---------------------|-----------------|--------------|-----------|--------------|-----------|
| | | | | | IPC/WHMA-A620 (1) | | Terminal (2) | | | |
| | | | | | AWG | mm ² | mm | In. | | |
| 5556 | 39-00-0038 | 39-00-0055 | 18-24 | 0.80-0.20 | 1.65-2.05 | .065-.085 | 1.30-3.10 | .051-.122 | 3.00-3.50 | .118-.138 |
| | 39-00-0059 | 39-00-0073 | | | | | | | | |
| | 39-00-0108 | 39-00-0114 | | | | | | | | |
| | 39-00-0153 | 39-00-0163 | | | | | | | | |
| | 39-00-0169 | 39-00-0175 | | | | | | | | |
| | 39-00-0181 | 39-00-0194 | | | | | | | | |
| | 39-00-0200 | 39-00-0207 | | | | | | | | |
| | 39-00-0213 | 39-00-0405 | | | | | | | | |
| | 39-00-0407 | 39-00-0410 | | | | | | | | |
| | 39-00-0419 | 39-00-0425 | | | | | | | | |
| | 39-00-0428 | 39-00-0436 | | | | | | | | |
| | 39-00-0440 | 40-13-0851 | | | | | | | | |
| 5558 | 39-00-0040 | 39-00-0053 | 18-24 | 0.80-0.20 | 1.65-2.05 | .065-.085 | 1.30-3.10 | .051-.122 | 3.00-3.50 | .118-.138 |
| | 39-00-0061 | 39-00-0075 | | | | | | | | |
| | 39-00-0120 | 39-00-0121 | | | | | | | | |
| | 39-00-0126 | 39-00-0219 | | | | | | | | |
| | 39-00-0411 | 39-00-0420 | | | | | | | | |
| | 39-00-0426 | 39-00-0427 | | | | | | | | |
| | 39-00-0430 | 39-00-0437 | | | | | | | | |
| | 40-01-0853 | 40-13-0853 | | | | | | | | |
| 98-00-0174 | | | | | | | | | | |
| 30490 | 30490-0002 | 30490-1002 | 18-24 | 0.80-0.20 | 1.65-2.05 | .065-.085 | 1.30-3.10 | .051-.122 | 3.00-3.50 | .118-.138 |
| | 30490-2002 | | | | | | | | | |
| 44476 | 44476-1111 | 44476-1211 | 18-20 | 0.80-0.50 | 1.65-2.05 | .065-.085 | 1.30-3.10 | .051-.122 | 3.00-3.50 | .118-.138 |

| Terminal Series No. | Terminal Order No. | | Wire Size | | Insulation Diameter | | | | Strip Length | |
|---------------------|--------------------|------------|-----------|-----------------|---------------------|-----------|--------------|-----------|--------------|-----------|
| | | | | | IPC/WHMA-A620 (1) | | Terminal (2) | | | |
| | | | AWG | mm ² | mm | In. | mm | In. | mm | In. |
| 44478 | 44478-1111 | 44478-1211 | 18-20 | 0.80-0.50 | 1.65-2.05 | .065-.085 | 1.30-3.10 | .051-.122 | 3.00-3.50 | .118-.138 |
| 44485 | 44485-1211 | 44485-1311 | 18-24 | 0.80-0.20 | 1.65-2.05 | .065-.085 | 1.30-3.10 | .051-.122 | 3.00-3.50 | .118-.138 |
| | 44485-1411 | | | | | | | | | |
| 45750 | 45750-1111 | 45750-1211 | 18-20 | 0.80-0.50 | 1.65-2.05 | .065-.085 | 1.65-2.95 | .065-.116 | 3.00-3.50 | .118-.138 |
| 46012 | 46012-1111 | 46012-1141 | 18-20 | 0.80-0.50 | 1.65-2.05 | .065-.085 | 1.65-2.95 | .065-.116 | 3.00-3.50 | .118-.138 |
| | 46012-1211 | 46012-1241 | | | | | | | | |
| 46018 | 46018-1541 | | 18-20 | 0.80-0.50 | 1.65-2.05 | .065-.085 | 1.65-2.95 | .065-.116 | 3.00-3.50 | .118-.138 |
| 46083 | 46083-1111 | 46083-1121 | 18-20 | 0.80-0.50 | 1.65-2.05 | .065-.085 | 1.65-2.95 | .065-.116 | 3.00-3.50 | .118-.138 |
| | 46083-1211 | 46083-1221 | | | | | | | | |
| 46098 | 46098-1541 | | 18-20 | 0.80-0.50 | 1.65-2.05 | .065-.085 | 1.65-2.95 | .065-.116 | 3.00-3.50 | .118-.138 |
| 46134 | 46134-1111 | 46134-1121 | 18-20 | 0.80-0.50 | 1.65-2.05 | .065-.085 | 1.65-2.95 | .065-.116 | 3.00-3.50 | .118-.138 |
| | 46134-1211 | 46134-1221 | | | | | | | | |

(1) To achieve optimum IPC-A620 insulation crimps, use this insulation OD range (example UL1007).

(2) Overall insulation OD specification for terminal.

Applicator 63900-2600 should be used for insulation OD 2.50-2.95mm (example UL1015).

Applicator 63901-5600 should be used for insulation OD 1.90-2.30mm.

Applicator 63902-3900 should be used for insulation OD 1.40-1.70mm.

DEFINITION OF TERMS

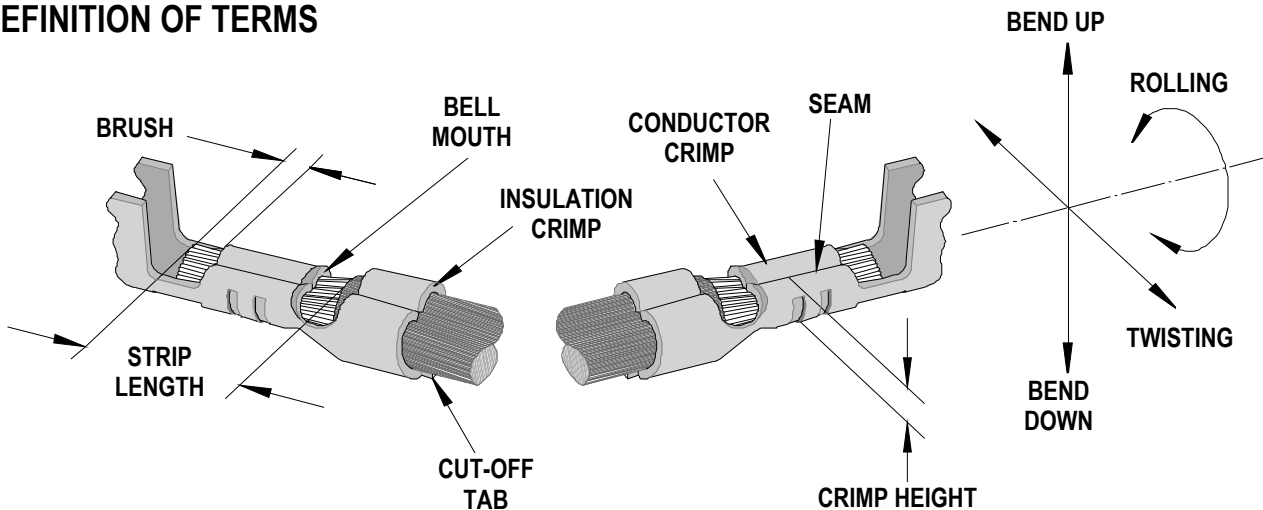

The above terminal drawing is a generic terminal representation. It is not an image of a terminal listed in the scope.

CRIMP SPECIFICATION

| Terminal Series No. | Bell mouth | | Cut-off Tab Maximum | | Conductor Brush | |
|------------------------|------------|-----------|---------------------|------|-----------------|-----------|
| | mm | In. | mm | In. | mm | In. |
| 5556 and 5558 | 0.20-0.50 | .008-.020 | 0.30 | .012 | 0.00-1.00 | .000-.039 |
| 30490 | 0.20-0.50 | .008-.020 | 0.30 | .012 | 0.00-1.00 | .000-.039 |
| 44476, 44478 and 44485 | 0.20-0.50 | .008-.020 | 0.30 | .012 | 0.00-1.00 | .000-.039 |
| 45750 | 0.20-0.50 | .008-.020 | 0.30 | .012 | 0.00-1.00 | .000-.039 |
| 46012 and 46018 | 0.20-0.50 | .008-.020 | 0.30 | .012 | 0.00-1.00 | .000-.039 |
| 46083 | 0.20-0.50 | .008-.020 | 0.30 | .012 | 0.00-1.00 | .000-.039 |
| 46098 | 0.20-0.50 | .008-.020 | 0.30 | .012 | 0.00-1.00 | .000-.039 |
| 46134 | 0.20-0.50 | .008-.020 | 0.30 | .012 | 0.00-1.00 | .000-.039 |

| Terminal Series No. | Bend up | Bend down | Twist | Roll | Punch Width (Ref) | | | | Seam Seam shall not be open And no wire allowed out of the crimping area |
|------------------------|---------|-----------|--------|------|-------------------|------|------------|------|---|
| | | | | | Conductor | | Insulation | | |
| | Degree | | Degree | | mm | In. | mm | In. | |
| 5556 and 5558 | 5 | 2 | 5 | 15 | 1.60 | .063 | 2.00 | .079 | |
| 30490 | 5 | 2 | 5 | 15 | 1.60 | .063 | 2.00 | .079 | |
| 44476, 44478 and 44485 | 5 | 2 | 5 | 15 | 1.60 | .063 | 2.00 | .079 | |
| 45750 | 5 | 2 | 5 | 15 | 1.60 | .063 | 2.00 | .079 | |
| 46012 and 46018 | 5 | 2 | 5 | 15 | 1.60 | .063 | 2.00 | .079 | |
| 46083 | 5 | 2 | 5 | 15 | 1.60 | .063 | 2.00 | .079 | |
| 46098 | 5 | 2 | 5 | 15 | 1.60 | .063 | 2.00 | .079 | |
| 46134 | 5 | 2 | 5 | 15 | 1.60 | .063 | 2.00 | .079 | |

After crimping, the crimp profiles should measure the following:

| Terminal Series No. | Wire Size | | Conductor | | | | Pull Force Minimum | |
|---------------------|-----------|-----------------|--------------|-----------|-------------------|------|--------------------|------|
| | | | Crimp Height | | Crimp Width (Ref) | | | |
| | AWG | mm ² | mm | In. | mm | In. | N | Lb. |
| 5556 | 18 | 0.80 | 0.97-1.07 | .038-.042 | 1.68 | .066 | 88.0 | 19.8 |
| | 20 | 0.50 | 0.95-1.04 | .037-.041 | 1.66 | .065 | 58.7 | 13.2 |
| | 22 | 0.35 | 0.85-0.94 | .033-.037 | 1.65 | .065 | 39.1 | 8.8 |
| | 24 | 0.20 | 0.79-0.87 | .031-.034 | 1.63 | .064 | 29.3 | 6.6 |
| 5558 | 18 | 0.80 | 0.97-1.07 | .038-.042 | 1.68 | .066 | 88.0 | 19.8 |
| | 20 | 0.50 | 0.95-1.04 | .037-.041 | 1.66 | .065 | 58.7 | 13.2 |
| | 22 | 0.35 | 0.85-0.94 | .033-.037 | 1.65 | .065 | 39.1 | 8.8 |
| | 24 | 0.20 | 0.79-0.87 | .031-.034 | 1.63 | .064 | 29.3 | 6.6 |
| 30490 | 18 | 0.80 | 0.97-1.07 | .038-.042 | 1.68 | .066 | 88.0 | 19.8 |
| | 20 | 0.50 | 0.95-1.04 | .037-.041 | 1.66 | .065 | 58.7 | 13.2 |
| | 22 | 0.35 | 0.85-0.94 | .033-.037 | 1.65 | .065 | 39.1 | 8.8 |
| | 24 | 0.20 | 0.79-0.87 | .031-.034 | 1.63 | .064 | 29.3 | 6.6 |
| 44476 | 18 | 0.80 | 0.97-1.07 | .038-.042 | 1.68 | .066 | 68.4 | 15.4 |
| | 20 | 0.50 | 0.95-1.04 | .037-.041 | 1.66 | .065 | 58.7 | 13.2 |
| 44478 | 18 | 0.80 | 0.97-1.07 | .038-.042 | 1.68 | .066 | 68.4 | 15.4 |
| | 20 | 0.50 | 0.95-1.04 | .037-.041 | 1.66 | .065 | 58.7 | 13.2 |
| 44485 | 18 | 0.80 | 0.97-1.07 | .038-.042 | 1.68 | .066 | 88.0 | 19.8 |
| | 20 | 0.50 | 0.95-1.04 | .037-.041 | 1.66 | .065 | 58.7 | 13.2 |
| | 22 | 0.35 | 0.85-0.94 | .033-.037 | 1.65 | .065 | 39.1 | 8.8 |
| | 24 | 0.20 | 0.79-0.87 | .031-.034 | 1.63 | .064 | 29.3 | 6.6 |
| 45750 | 18 | 0.80 | 0.97-1.07 | .038-.042 | 1.68 | .066 | 68.4 | 15.4 |
| | 20 | 0.50 | 0.84-0.94 | .033-.037 | 1.66 | .065 | 58.7 | 13.2 |
| 46012 | 18 | 0.80 | 0.97-1.07 | .038-.042 | 1.68 | .066 | 68.4 | 15.4 |
| | 20 | 0.50 | 0.84-0.94 | .033-.037 | 1.66 | .065 | 58.7 | 13.2 |
| 46018 | 18 | 0.80 | 0.97-1.07 | .038-.042 | 1.68 | .066 | 68.4 | 15.4 |
| | 20 | 0.50 | 0.84-0.94 | .033-.037 | 1.66 | .065 | 58.7 | 13.2 |
| 46083 | 18 | 0.80 | 0.97-1.07 | .038-.042 | 1.68 | .066 | 68.4 | 15.4 |
| | 20 | 0.50 | 0.84-0.94 | .033-.037 | 1.66 | .065 | 58.7 | 13.2 |
| 46098 | 18 | 0.80 | 0.97-1.07 | .038-.042 | 1.68 | .066 | 68.4 | 15.4 |
| | 20 | 0.50 | 0.84-0.94 | .033-.037 | 1.66 | .065 | 58.7 | 13.2 |
| 46134 | 18 | 0.80 | 0.97-1.07 | .038-.042 | 1.68 | .066 | 68.4 | 15.4 |
| | 20 | 0.50 | 0.84-0.94 | .033-.037 | 1.66 | .065 | 58.7 | 13.2 |

*** Tool Qualification Notes:**

1. Pull Force should be measured with no influence from the insulation crimp.
2. The above specifications are guidelines to an optimum crimp.

PARTS LIST

| FineAdjust Applicator 63900-2900 | | | | |
|--|-----------------|------------------------|------------------------------------|-----------------|
| Item | Order No | Engineering No. | Description | Quantity |
| Perishable Tooling | | | | |
| | 63900-2970 | 63900-2970 | Tool Kit (All "Y" Items) | REF |
| 1 | 63444-1609 | 63444-1609 | Conductor Punch | 1 Y |
| 2 | 63445-1646 | 63445-1646 | Conductor Anvil | 1 Y |
| 3 | 63446-2001 | 63446-2001 | Insulation Punch | 1 Y |
| 4 | 63445-2005 | 63445-2005 | Insulation Anvil | 1 Y |
| 5 | 63443-0002 | 63443-0002 | Front Cut-Off Plunger | 1 Y |
| 6 | 63443-0012 | 63443-0012 | Front Plunger Retainer | 1 Y |
| Other Components | | | | |
| 7 | 11-18-4083 | 60707-8 | Feed Guide | 1 |
| 8 | 11-24-1067 | 4996-4 | Cut-Off Plunger Spring | 1 |
| 9 | 63443-0009 | 63443-0009 | Front Scrap Chute | 1 |
| 10 | 63443-0024 | 63443-0024 | Key | 1 |
| 11 | 63443-0090 | 63443-0090 | Wire Stop | 1 |
| 12 | 63443-1717 | 63443-1717 | 18.70mm Height Spacer | 1 |
| 13 | 63443-2216 | 63443-2216 | 16.00mm Coarse Spacer | 1 |
| 14 | 63443-2302 | 63443-2302 | 3.10mm Fine Spacer | 1 |
| 15 | 63443-2802 | 63443-2802 | Plunger Striker | 1 |
| 16 | 63443-2907 | 63443-2907 | Wire Hold Down Plunger | 1 |
| 17 | 63443-6111 | 63443-6111 | Rear Cover | 1 |
| 18 | 63600-1057 | 63600-1057 | Compression Spring | 1 |
| Frame | | | | |
| 19 | 63800-4901 | 63800-4901 | Top | 1 |
| 20 | 63801-3281 | 63801-3281 | Base | 1 |
| 21 | 63801-4650 | 63801-4650 | Track | 1 |
| Hardware | | | | |
| 22 | N/A | N/A | M3 by 6 Long SHCS | 2** |
| 23 | N/A | N/A | M3 by 6 Long FHCS | 1** |
| 24 | N/A | N/A | M4 by 6 Long SHCS | 2** |
| 25 | N/A | N/A | M4 by 12 Long BHCS | 2** |
| 26 | N/A | N/A | M4 by 50 Long SHCS | 2** |
| 27 | N/A | N/A | M5 by 12 Long SHCS | 1** |
| 28 | N/A | N/A | #10-32 by 3/8" Long Flat Point SSS | 1** |
| 29 | N/A | N/A | #10-32 Hex Jam Nut | 1** |
| ** Available from an industrial supply company such as MSC (1-800-645-7270). | | | | |

Assembly Drawing

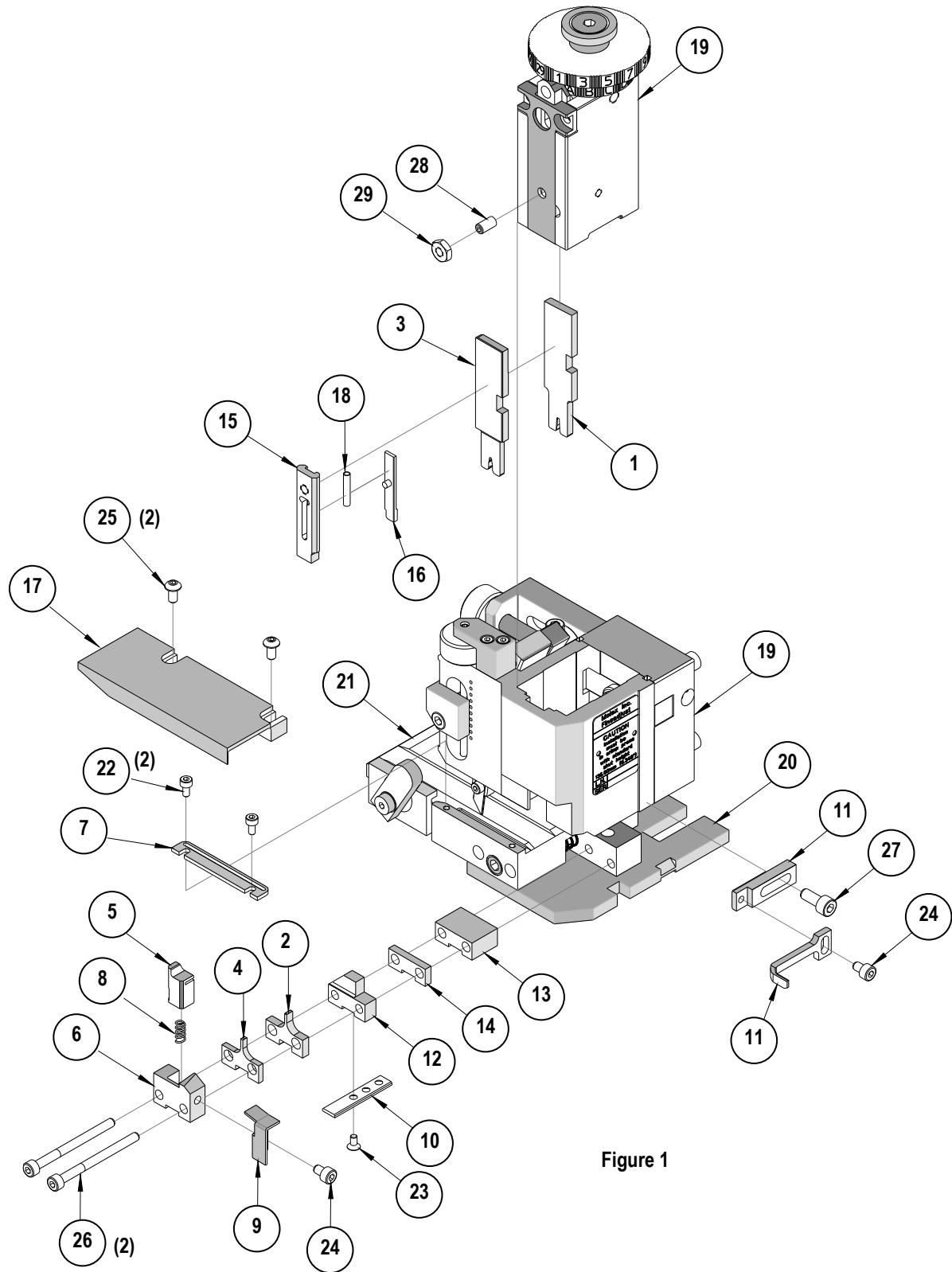

Figure 1

NOTES

1. Molex recommends an extra perishable tooling kit be maintained at your facility.
2. Verify tooling alignment by manually cycling the press and Applicator before crimping under power. Check that all screws are tight.
3. Slugs, Terminals, Dirt and Oil should be kept clear of work area.
4. Wear safety glasses at all times.
5. For recommended maintenance refer to the FineAdjust Manual.

CAUTION: This applicator should only be used in a press with a shut height of 135.80 mm (5.346"). Tooling damage could result at a lower setting.

CAUTION: To prevent injury never operate this Applicator without the guards supplied with the press or wire-processing machine in place. Reference the press or wire processing manufacturer's instruction manual.

CAUTION: Molex crimp specifications are valid only when used with Molex terminals, applicators and tooling.

<http://www.molex.com>