



275

Digital Clamp-on Meter Instruction Manual



TABLE OF CONTENTS

A. INTRODUCTION	
1. Congratulations	3
2. Product Description	3
3. Declaration of Conformity	4
B. SAFETY CONSIDERATIONS	5
C. TECHNICAL DATA	
1. Features and Benefits.....	6
2. Product Applications	7
3. Specifications.....	8
D. MEASUREMENT TECHNIQUES	
1. Controls and Functions	12
2. Step by Step Procedures:	14
E. OTHER FEATURES	24
F. APPLICATION NOTES	29
G. TROUBLE SHOOTING GUIDE	34
H. MAINTENANCE	35
I. ACCESSORIES	36

A. INTRODUCTION

1. Congratulations!!

Thank you for purchasing TPI products. The 275 is easy to use and is built to last. It is backed by a 3 year limited warranty. Please remember to complete and return your product warranty registration card.

2. Product Description

The slim design 275 is a hand-held, autoranging clamp-on DMM. Extra large numerals, DC amps, min/max, capacitance, DC microamps and duty cycle are just a few of the features of the 275. An affordable choice, the 275 offers measurements in all basic electrical functions with additional advanced features like non-contact voltage.

The 275 comes complete with the following accessories:

Carrying Pouch
Test Lead Set
Temperature Probe
Instruction Manual
Battery & Fuse

3. EC Declaration of Conformity

This is to certify that TPI Model 275 conforms to the protection requirements of the council directive 89/336/EEC, in the approximation of laws of the member states relating to Electromagnetic compatibility and 73/23/EEC. The Low Voltage Directive by application of the following standards:

EN 50081-1	1992 Emissions Standard
EN 50082-1	1992 Immunity Standard
EN 61010-1	1993 Safety Standard
EN 61010-2-031	1995 Safety Standard
EN 61010-2-032	1995 Safety Standard

To ensure conformity with these standard, this instrument must be operated in accordance with the instructions and specifications given in this manual.

CAUTION: Even though this instrument complies with the immunity standards, it's accuracy can be affected by strong radio emissions not covered in the above standards. Sources such as hand-held radio transceivers, radio and TV transmitters, vehicle radios and cellular phones generate electromagnetic radiation that could be induced into the test leads of this instrument. Care should be taken to avoid such situations or alternatively, check to make sure that the instrument is not being influence by these emissions.

CAUTION: Please follow manufacturers test procedures whenever possible. Do not attempt to measure unknown voltages or components until a complete understanding of the circuit is obtained.

B. SAFETY CONSIDERATIONS



WARNING: Please follow manufacturers test procedures whenever possible. Do not attempt to measure unknown voltages or components until a complete understanding of the circuit is obtained.

GENERAL GUIDELINES

ALWAYS

- Test the 275 before using it to make sure it is operating properly.
- Inspect the test leads before using to make sure there are no breaks or shorts.
- Double check all connections before testing.
- Have someone check on you periodically if working alone.
- Have a complete understanding of the circuit being measured.
- Disconnect power to circuit, then connect test leads to the 275, then to circuit being measured.

NEVER

- Attempt to measure unknown high voltages.
- Attempt to measure DC microamps with the meter in parallel to the circuit.
- Connect the test leads to a live circuit before setting up the instrument.
- Touch any exposed metal part of the test lead assembly.

INTERNATIONAL SYMBOLS

 **CAUTION: RISK OF ELECTRIC SHOCK**

 **AC (Alternation Current)**

 **DC (Direct Current)**

 **REFER TO INSTRUCTION MANUAL**

 **GROUND**

 **DOUBLE INSULATION**

 **EITHER DC OR AC**

C. TECHNICAL DATA

1. Features and Benefits

Agency	Meets CE and IEC 1010.
Analog Bar Graph	Displays rapidly changing input signals.
NCV	Non-contact voltage detection. Detect the presence of voltage without contacting the circuit.
P-H MAX/MIN	Captures min / max peak. Records Min/Max readings for all functions and ranges.
REL	Measurements made are displayed relative to a stored value.
Auto Off	Automatically powers off after 30 minutes of inactivity.

2. Product Applications

Perform the following tests and/or measurements with the 275 and the appropriate function:

HVAC/R

- DCmV** • Thermocouples in furnaces.
- ACA** • Heat anticipator current in thermostats.
- ACV** • Line voltage.
- ACV or DCV** • Control circuit voltage.
- DC μ A** • Flame safeguard control current.
- OHMS** • Compressor winding resistance.
- OHMS** • Continuity of wiring.
- CAP** • Motor start and run capacitors.
- ACA** • Motor and compressor start up current.
- Hz** • Frequency on controls and line voltage.
- TEMP** • Air duct temperatures.
- ALL** • Bar graph to indicate rapid fluctuations.

ELECTRICAL

- ACV** • Measure line voltage.
- ACA** • Measure line current.
- OHMS** • Continuity of circuit breakers.
- DCV** • Voltage of direct drive DC motors.
- ACA** • Start up current of motors, relays, contactors and transformers.

ELECTRONIC

- ACV** • Measure power supply voltage.
- ACA** • Measure power supply current.
- OHMS** • Continuity of circuit breakers and fuses.

3. Specifications



IEC 1010 Over Voltage:

CAT II - 1000V

CAT III - 600V

Pollution Degree 2

UL 3111 Pending

Temperature for guaranteed accuracy: 23°C ±5°C

DC VOLTS

Range	Res.	Accuracy	
110mV	0.1mV	+/- (0.5% of reading + 2 digits)	Impedance:
1V	0.001V		10MΩ
11V	0.01V		Overload Protection:
110V	0.1V		600VDC or AC RMS
600V	1V		

AC VOLTS

(45Hz to 100Hz Frequency Response 400mV Range)
(45Hz to 450Hz Frequency Response All Other Ranges)

Range	Res.	Accuracy	
110mV	0.1mV	+/- (1.2% of reading + 5 digits)	Impedance:
1V	0.001V	+/- (1.2% of reading + 3 digits)	10MΩ
11V	0.01V	+/- (1.5% of reading + 3 digits)	Overload Protection:
110V	0.1V		600VDC or AC RMS
600V	1V		

AC AMPS

(45Hz to 100Hz Frequency Response 200A to 400A)
(45Hz to 450Hz Frequency Response Below 200A)

Range	Res.	Accuracy
110A	0.01A	+/- (3.0% of reading + 5 digits)
400A	0.1A	

DC Microamps

Range	Res.	Accuracy	
110uA	0.01μA	+/- (0.8% of reading + 2 digits)	Overload Protection: 0.5A / 600V Fuse
1100uA	0.1μA		

* DC microamps are measured with the test leads in series with the circuit under test.

DC AMPS

Range	Res.	Accuracy
110A	0.01A	+/- (3% of reading + 10 digits)
400A	0.1A	

OHM (Resistance, Ω)

Range	Res.	Accuracy	
110Ω	0.01Ω	±(1% of reading +5 digits)	Overload Protection: 250VDC or AC RMS
1kΩ	0.0001kΩ	±(1% of reading +2 digits)	
11kΩ	0.001kΩ		
110kΩ	0.01kΩ		
1MΩ	0.0001MΩ	±(3% of reading +5 digits)	
11MΩ	0.001MΩ	±(3% of reading +10 digits)	
110MΩ	0.1MΩ	±(3% of reading +10 digits)	

Frequency (Hz)

Range	Res.	Accuracy	
1100.0Hz	0.1Hz	±(1% of reading +2 digits)	Overload Protection: 250VDC or AC RMS
11.000kHz	0.001kHz		
110.00MHz	0.01kHz		
1.1000MHz	0.0001MHz		
11.000MHz	0.001MHz		
110.00MHz	0.01MHz		



Warning:

Use only correct type and overvoltage category rated test leads. Remove the temperature probe when using the test leads or amp clamp.

Diode Test

Test Current

1.5mA MAX

Over Load Protection

250 V DC or AC RMS

Continuity Buzzer

Test Voltage

3V

Threshold

<35Ω

Over Load Protection

250 V DC or AC RMS

Non-Contact Voltage (NCV)

Detection Range: 24VAC and above

Temperature (K-Type thermocouple)

Range

-30°F to 1000°F

Res.

1°F

Accuracy

±(2°F) 32.0°F to 120°F

± (1%+2°F) -3°F to 749°F

± (2%+1.5°F) 750°F to 1000°F

± (2%+4°F) -40°F to -4°F

Overload Protection: 60VDC or 30VAC RMS

**Celsius version of the 275 is available



Warning:

Use only correct type and overvoltage category rated test leads. Remove the temperature probe when using the test leads or amp clamp.

Capacitance

Range	Res.	Accuracy	
11nF	0.001nF	±(3% of reading +5 digits)	Overload Protection: 500VDC or AC RMS
110nF	0.01nF		
1.1µF	0.0001µF		
11µF	0.001µF		
110µF	0.01µF		
1.1mF	0.0001mF		
11mF	0.001mF	±(7% of reading +5 digits)	
110mF	0.01mF		

nF= nanofarad, µF= microfarad, mF= millifarad

General

Max Voltage between any input and ground	600V
Fuse Protection (µA range)	0.5A/600V
Display Type	4000 Count 41 seg. bargraph
Operating Temperature	32°F to 104°F (0°C to 40°C)
Storage Temperature	14°F to 122°F (-10°C to 50°C)
Relative Humidity	80% non-condensing
Power Supply	9V (MN1604)
Battery Life	80 hrs. typical
Size (H x L x W)	32.5mm x 255mm x 65mm (1.3in x 10in x 2.5in)
Weight	363g (0.8lbs)

 **Warning:** Use only correct type and overvoltage category rated test leads. Remove the temperature probe when using the test leads or amp clamp.

D. MEASUREMENT TECHNIQUES







1. Controls and Functions:

Push Buttons

- REL** Activates Relative mode. Press and hold for 2 seconds to deactivate.
- D-H** Holds the reading on the display until the button is pushed a second time.
- R-H** Activates manual ranging. Press and hold for 2 seconds to return to auto ranging.
- MAX MIN** Activates record mode. Press to cycle between maximum and minimum recorded reading. Press and hold for 2 seconds to return to normal mode.
- P-H** Activates peak hold mode. Used to capture in-rush current.
- NCV** Activates the non-contact voltage detection feature. Press and hold while holding the jaw close to electrical wires.

1. Controls and Functions: (cont.)

Rotary Switch

- OFF** Turns the 275 completely off.
-  Used to measure DC volts.
-  Used to measure AC volts.
- Ω Used to measure resistance.
-  Used to measure continuity.
-  Selects diode test function.
-  Selects capacitance test function.
- Hz** Selects frequency test function.
-  Selects DC microamp function.
-  Used to measure AC amperage.
- TEMP** Selects the temperature function.

Input Jacks

- COM** Black test lead connection for all tests except temperature, non-contact voltage and AC Amps.
- V/ Ω / μ A** Red test lead connection for all tests except temperature, non-contact voltage and AC Amps.

2. Step by Step Procedures:

Measuring DC Voltage

 **WARNING!**

Do not attempt to make a voltage measurement of more than 600V or of a voltage level that is unknown. Make sure the temperature probe is NOT plugged in during this test.

Instrument set-up:

FUNC.	BLACK TEST LEAD	RED TEST LEAD	MIN READING	MAXI READING
	COM	V/ Ω	0.1mV	600V

Measurement Procedure:

1. Disconnect power to circuit to be measured.
2. Plug black test lead into the **COM** input jack.
3. Plug red test lead into the **V/ Ω** input jack.
4. Set rotary switch to the **\overline{V}** range.
5. Connect test leads to circuit to be measured.
6. Reconnect power to circuit to be measured.
7. Read the voltage on the 275.

Optional Modes (See Other Features Section)

- **D-H:** Freezes the reading on the LCD.
- **MAX/MIN:** Records minimum a.
- **P-H:** Displays peak voltage.

Measuring AC Voltage



WARNING!

Do not attempt to make a voltage measurement of more than 600V or of a voltage level that is unknown. Make sure the temperature probe is NOT plugged in during this test.

Instrument set-up:

FUNC.	BLACK TEST LEAD	RED TEST LEAD	MIN READING	MAX READING
	COM	V/Ω	0.1mV	600V

Measurement Procedure:

1. Disconnect power to circuit to be measured.
2. Plug black test lead into the **COM** input jack.
3. Plug red test lead into the **V/Ω** input jack.



4. Set rotary switch to the **V** range.
5. Connect test leads to circuit to be measured.
6. Reconnect power to circuit to be measured.
7. Read the voltage on the 275.

Optional Modes (See Other Features Section)

- **D-H:** Freezes the reading on the LCD.
- **MAX/MIN:** Records minimum and maximum measurements.
- **P-H:** Displays peak voltage.

Measuring Resistance

WARNING!

*Do not attempt to make resistance measurements with circuit energized. For best results, remove the resistor completely from circuit before attempting to measure it. Make sure the temperature probe is **NOT** plugged in during this test.*

NOTE:

To make accurate low ohm measurements, short the ends of the test leads together and press the REL button to store the reading. This will deduct the stored value from subsequent measurements eliminating the test lead resistance from the reading.

Instrument set-up:

FUNC.	BLACK TEST LEAD	RED TEST LEAD	MIN READING	MAX READING
Ω	COM	V/ Ω	0.1 Ω	40.00M Ω

Measurement Procedure:

1. Disconnect power to circuit to be measured.
2. Plug black test lead into the **COM** input jack.
3. Plug red test lead into **V/ Ω** input jack.
4. Set the rotary switch to the Ω function.
5. Connect test leads to circuit to be measured.
6. Read the resistance value on the 275.

Optional Modes (See Other Features Section)

- **D-H:** Freezes the reading on the LCD.

Measuring AC Amperage

CAUTION!

Do not attempt to make a current measurement with the test leads. The 275 measures the current by clamping the jaw around one conductor (wire). Clamping around more than one wire will result in erroneous readings. Make sure the temperature probe is NOT plugged in during this test.

Instrument set-up:

FUNC.	BLACK TEST LEAD	RED TEST LEAD	MIN READING	MAX READING
	NOT USED	NOT USED	0.01A	400A

Measurement Procedure:

1. Disconnect power to circuit to be measured.
2. Set rotary switch to  function.
3. Clamp the jaws around one conductor of the circuit to be measured. For best results, center the wire in the jaw.
4. Reconnect power to circuit to be measured.
5. Read the current on the 275.

Optional Modes (See Other Features Section)

- **D-H:** Freezes the reading on the LCD.
- **MAX/MIN:** Records minimum and maximum measurements
- **P-H:** Displays peak amperage.

Measuring DC Amperage

CAUTION!

Do not attempt to make a current measurement with the test leads. The 275 measures the current by clamping the jaw around one conductor (wire). Clamping around more than one wire will result in erroneous readings. Make sure the temperature probe is NOT plugged in during this test.

Instrument set-up:

FUNC.	BLACK TEST LEAD	RED TEST LEAD	MIN READING	MAX READING
	NOT USED	NOT USED	0.01A	400A

Measurement Procedure:

1. Disconnect power to circuit to be measured.
2. Set rotary switch to function.
3. Clamp the jaws around one conductor of the circuit to be measured. For best results, center the wire in the jaw.
4. Reconnect power to circuit to be measured.
5. Read the current on the 275.

Optional Modes (See Other Features Section)

- **D-H:** Freezes the reading on the LCD.
- **MAX/MIN:** Records minimum and maximum measurements
- **P-H:** Displays peak amperage.



Measuring Continuity

 **WARNING!**
Do not attempt to make continuity measurements with circuit energized. Make sure the temperature probe is NOT plugged in during this test.

Instrument set-up:

FUNC.	BLACK TEST LEAD	RED TEST LEAD
	COM	V/ Ω

Measurement Procedure:

1. Disconnect power to circuit to be measured.
2. Plug black test lead into the **COM** input jack.
3. Plug red test lead into **V/ Ω** input jack.
4. Set the rotary switch to the  position.
5. Connect test leads to circuit to be measured.
6. The 275 will beep and the  LED will illuminate at resistances of 35Ω or lower.

Optional Modes (See Other Features Section)

- **D-H:** Freezes the reading on the LCD.

Measuring Diodes



WARNING!

Do not attempt to make diode measurements with the circuit energized. For accurate tests, remove the diode completely from the circuit prior to measuring it. Make sure the temperature probe is NOT plugged in during this test.

Instrument set-up:

FUNC.	BLACK TEST LEAD	RED TEST LEAD
	COM	V/ Ω / μ A

Measurement Procedure:

1. Disconnect power to circuit to be measured.
2. Plug black test lead into the **COM** input jack.
3. Plug red test lead into **V/ Ω** input jack.
4. Set the rotary switch to the position.
5. Connect the black test lead to the banded end of the diode (cathode) and the red test lead to the non-banded end of the diode (anode).
6. For a good diode, the reading on the display should be between 0.5V and 0.8V. The reading will be lower for a germanium diode.
7. Reverse the leads on the diode.
8. For a good diode, the reading on the display should be OL (overload).

Optional Modes (See Other Features Section)

- **D-H:** Freezes the reading on the LCD.

Mea



A
C
a
i
a

I
F
—
—

Mea

1. D
2. F
3. F
4. S
5. F
6. C
7. F

Optic

- D

Measuring Capacitance

WARNING!

*All capacitance measurements are to be made on de-energized circuits with all capacitors discharged only. Failure to de-energize and discharge capacitors prior to measuring them could result in instrument damage and/or personal injury. Make sure the temperature probe is **NOT** plugged in during this test.*

Instrument set-up:

FUNC.	BLACK TEST LEAD	RED TEST LEAD
	COM	V/ Ω / μ A

Measurement Procedure:

1. Disconnect power to circuit to be measured.
2. Plug black test lead into the **COM** input jack.
3. Plug red test lead into **V/ Ω** input jack.
4. Set the rotary switch to the  position.
5. Remove the capacitor from the circuit and discharge it.
6. Connect test leads to the capacitor to be measured.
Observe polarity on polarity sensitive capacitors.
7. Read the capacitor value on the LCD.

Optional Modes (See Other Features Section)

- **D-H:** Freezes the reading on the LCD.

Measuring Frequency

WARNING!

*Never attempt a frequency measurement with a voltage source greater than 500V. Determine the voltage of any unknown frequency source before connecting the instrument in frequency mode. Make sure the temperature probe is **NOT** plugged in during this test.*

Instrument set-up:

FUNC.	BLACK TEST LEAD	RED TEST LEAD
Hz	COM	V/ Ω / μ A

Measurement Procedure:

1. Disconnect power to the circuit to be measured.
2. Plug black test lead into the **COM** input jack.
3. Plug red test lead into **V/ Ω** input jack.
4. Set the rotary switch to the **Hz** position.
5. Reconnect power to the circuit to be measured.
6. Read the frequency on the LCD.

Optional Modes (See Other Features Section)

- **D-H:** Freezes the reading on the LCD.
- **MAX/MIN:** Records minimum and maximum measurements

Measuring DC Microamps



CAUTION!

*Do not attempt to make a current measurement with the test leads connected in parallel with the circuit to be tested. Test leads must be connected in series with the circuit. Do not attempt to make a current measurement of circuits with more than 600V present. Instrument damage and/or personal injury may result. Make sure the temperature probe is **NOT** plugged in during this test.*

Instrument set-up:

FUNC.	BLACK TEST LEAD	RED TEST LEAD	MINIMUM READING	MAXIMUM READING
	COM	V/ Ω / μ A	0.01 μ A	400.0 μ A

Measurement Procedure:

1. Disconnect power to circuit to be measured.
2. Plug black test lead into the **COM** input jack.
3. Plug red test lead into the **V/ Ω / μ A** input jack.
4. Set the rotary switch to the **μ A** function.
5. Connect the test leads in series to the circuit to be measured.
6. Reconnect power to circuit to be measured.
7. Read the current on the 275.

Optional Modes (See Other Features Section)

- **D-H:** Freezes the reading on the LCD.
- **MAX/MIN:** Records minimum and maximum measurements.

Measuring Temperature



CAUTION!

Do not attempt to make a temperature measurement with the test leads connected to the 275. Remove the test leads and insert the K-type temperature probe.

Instrument set-up:

FUNC.	BLACK TEST LEAD	RED TEST LEAD	MINIMUM READING	MAXIMUM READING
400°F	N/A	N/A	-40.0°F	399.9°F
1000°F	N/A	N/A	-40°F	1000°F

Measurement Procedure:

1. Remove the test leads from the input jacks.
2. Observing polarity, insert the temperature probe into the Type K input jack.
3. Set the rotary switch to the appropriate function for the temperature being measured.
4. Touch the temperature probe to the item to be measured.
5. Read the temperature on the LCD.

Note: The 275 will beep when no probe is connected to the temperature input.

Optional Modes (See Other Features Section)

- **D-H:** Freezes the reading on the LCD.
- **MAX/MIN:** Records minimum and maximum measurements.
- **REL:** Enables temperature differential tests to be performed. See Application Notes section.



E. Other Features

Non-Contact Voltage (NCV)

 **WARNING!**

Never rely on the non-contact voltage function only. If a voltage is not detected, confirm there is no voltage by performing a voltage measurement with the test leads. Failure to do this could result in injury. The non-contact voltage feature works best when testing single wires. Make sure the test leads and temperature probe are disconnected while using the NCV feature.

Instrument set-up:

FUNC.	BLACK TEST LEAD	RED TEST LEAD
NCV	N/A	N/A

Measurement Procedure:

Remove the test leads and temperature probe prior to using the NCV feature.

1. Turn the meter on to any range.
2. Press and hold the NCV button.
3. Put the arrow marked on the jaw close to the wire under test.
4. If voltage is present the 275 will beep and the NCV LED will illuminate.
5. If voltage is not detected, confirm the result by performing a voltage measurement as outlined earlier in this manual.

Relative mode (REL)

The Relative mode (REL) takes the reading on the display at the time the **REL** button is pressed and uses it as a reference value that is deducted from all subsequent measurements. This can be very helpful in deducting the resistance of test leads in low ohm measurements.

1. To use **Relative** mode manually select the range for the function.
2. Depress the **REL** button to store the reading on the display. The “REL” indicator will illuminate confirming the 275 is in relative mode.
3. Now when making a measurement the value stored will be deducted from the actual reading.
4. To see what the stored value is, depress the **REL** button again and the “REL” indicator will flash and the reading on the display will show the stored value. Depress the **REL** button again to return to REL mode.
5. To clear or exit relative mode, press and hold the **REL** button for approximately two seconds and the 275 will beep and return to normal operation.

Note: Differential temperature measurements can be made using relative mode. See the application note on page 33 for more information.

Other Features (continued)

Record Mode (MAX / MIN)

Record mode allows you to record the maximum and minimum readings measured during a test.

1. Manually select the range for the function and set the meter up to perform a measurement as outlined earlier in this manual.
2. Depress the **MAX/MIN** button and “MAX” will be displayed along with the maximum reading recorded. Press the **MAX/MIN** button again and the display will show MIN and the minimum reading recorded.
3. Press the **MAX/MIN** button again and MAX MIN will blink and the 275 will display the measured value in real time. Steps 2 and 3 can be repeated to read the maximum and minimum recorded values.

If REL was activated and is being used with MAX/MIN, REL and MAX MIN will blink and the display will show the REL value instead of the real time reading.

5. To exit record mode, press and hold the **MAX/MIN** button for approximately two seconds and the 275 will beep and return to normal operation.

Other Features (continued)

Peak Hold Mode (P-H)

The Peak hold function allows the 275 to display the the maximum and minimum peak voltage or current. This is helpful when measuring inrush current.

NOTE: Peak mode can display up to 70 counts on the display when first activated. For example, if the 275 is set to the ACA function and manually ranged to the 40A range, when P-H is activated the display can read up to 0.70. This is normal for this function.

1. Manually select the range for the function and set the meter up to perform a measurement as outlined earlier in this manual.
2. Depress and hold the **P-H** button until CAL is displayed. Once CAL clears from the display you may make a measurement. Press **P-H** repeatedly to cycle through the maximum and minimum peak readings. Press and hold the **P-H** button for two seconds to return to normal operation.

For inrush current, after CAL clears press the **P-H** button and then supply power to the device under test. The 275 will capture the maximum and minimum peak inrush.

Other Features (continued)

Manual Ranging (R-H)

The range hold button (R-H) activates manual ranging. Press the R-H button to cycle through available ranges. Pressing and holding the R-H button for approximately two seconds returns the meter to autorange mode and “auto” will be displayed in the upper left corner of the display.

Data Hold (D-H)

Press the D-H button at any time to freeze the reading on the LCD display. This function is useful when measuring in locations where the display is difficult to read.

LED Indicators

The 275 is equipped with three LED indicators at the top near the jaw.

HI-V This indicator flashes and the 275 beeps when the test leads are in contact with a voltage of 30V AC/DC or more.

NCV This indicator illuminates when the non-contact voltage detector senses a voltage.



This is the visual indicator of continuity. This LED also flashes anytime the buzzer beeps.

F. Application Notes (AC Volts)

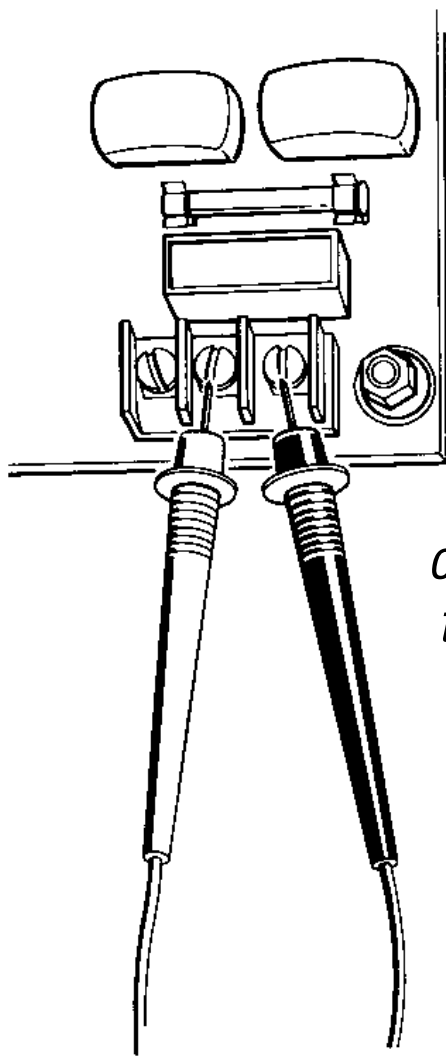

Disconnect power from the terminal block, find the fuse or circuit breaker that controls the block and turn it off.

Set up the meter following the steps under “Measurement Procedure” on page 15. Then proceed with the following:

- Connect the red test lead to the hot side of the block and the black lead to the neutral side of the block. Reconnect power to the block and read the voltage on the meter. The reading should be approximately 110V to 130V.*
- Disconnect power from the block and move the red wire to ground. Reconnect power to the block and read the voltage on the meter. Typically less than 20V should exist from neutral to ground. If 110V or above exists, the block may be wired incorrectly.*

Application Notes (DC Volts)

The 275 will accurately measure rectified DC Voltages like those encountered in furnaces and other appliances even though many of these devices do not have output filtering or other signal conditioning.

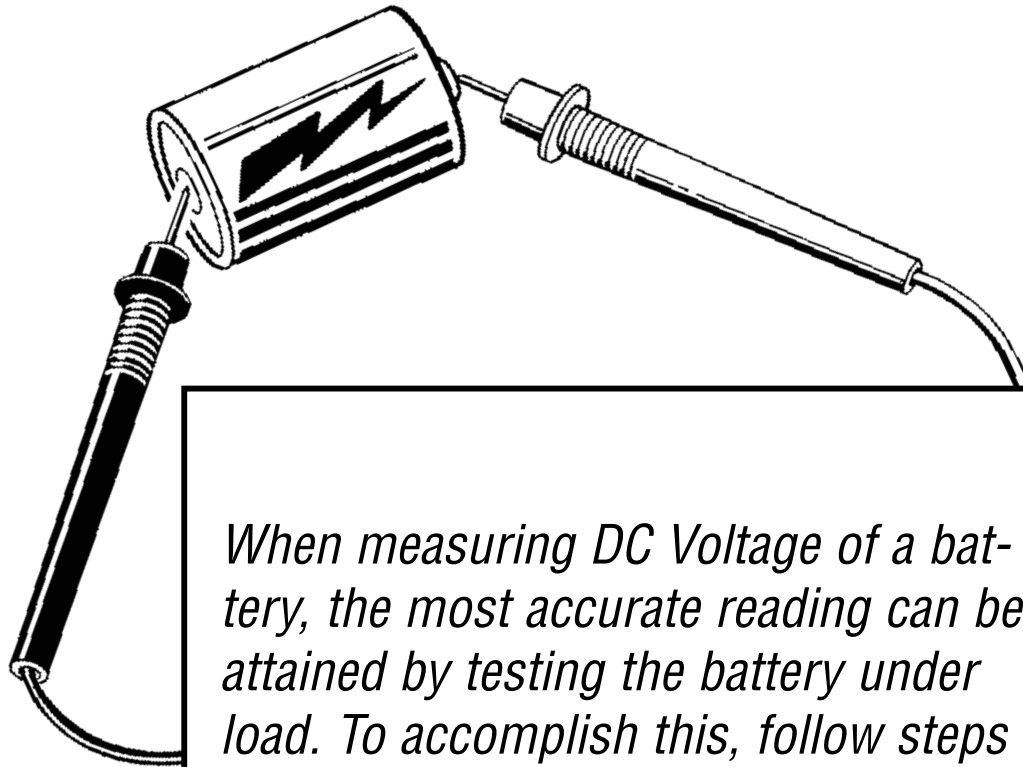

When measuring DC Voltage of a battery, the most accurate reading can be attained by testing the battery under load. To accomplish this, follow steps 1 through 4 shown on page 14 and the following (with the battery in holder and device turned on):

- Connect the red test lead from the meter to the positive (+) terminal of the battery.*
- Connect the black test lead to the negative (-) terminal of the battery.*

Application Notes (Resistance)

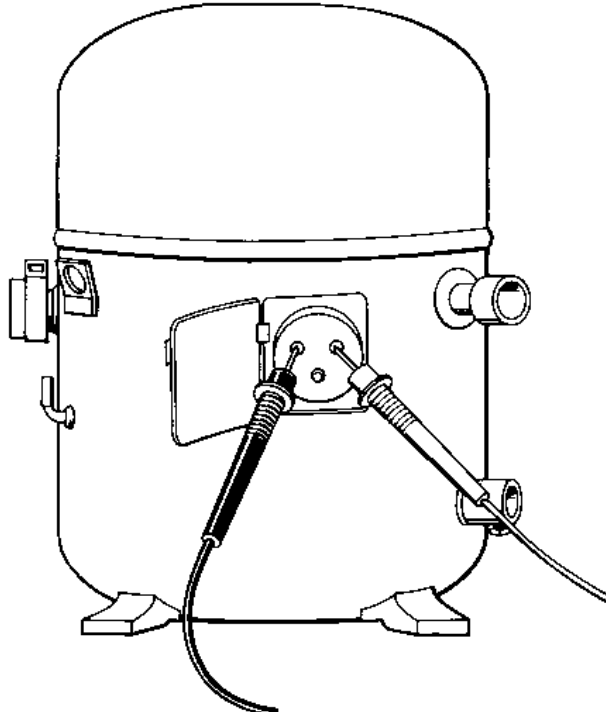

When measuring resistance of a motor, make sure the power is disconnected prior to testing. Set up meter following steps under “Measurement Procedure” on page 16, and proceed with the following:

- Connect the red test lead to one power input line of the motor and the black test lead to the other power input line of the motor. In most applications if the reading is OFL, the motor winding is open.*
- Connect the red test lead to the frame of the motor and the black test lead to the winding. In most applications if a reading of 0 Ohms is displayed, the winding is shorted to the motor frame (ground).*

Application Notes (AC Amps)

When measuring AC Amps of a motor there are two types of measurements that can be made, running current and in-rush or start-up current. Start-up current will usually be much higher than running current.

Set up the meter following the steps under “Measurement Procedure” on page 17, and then proceed with the following:

- *Clamp the meter around a single wire and reconnect power to the device. Read the current displayed on the meter. This is the running current of the motor.*
- *Disconnect power to the motor and put the meter in PEAK HOLD mode. Reconnect the power and read the current displayed on the meter. This is the in-rush or start-up current of the motor.*

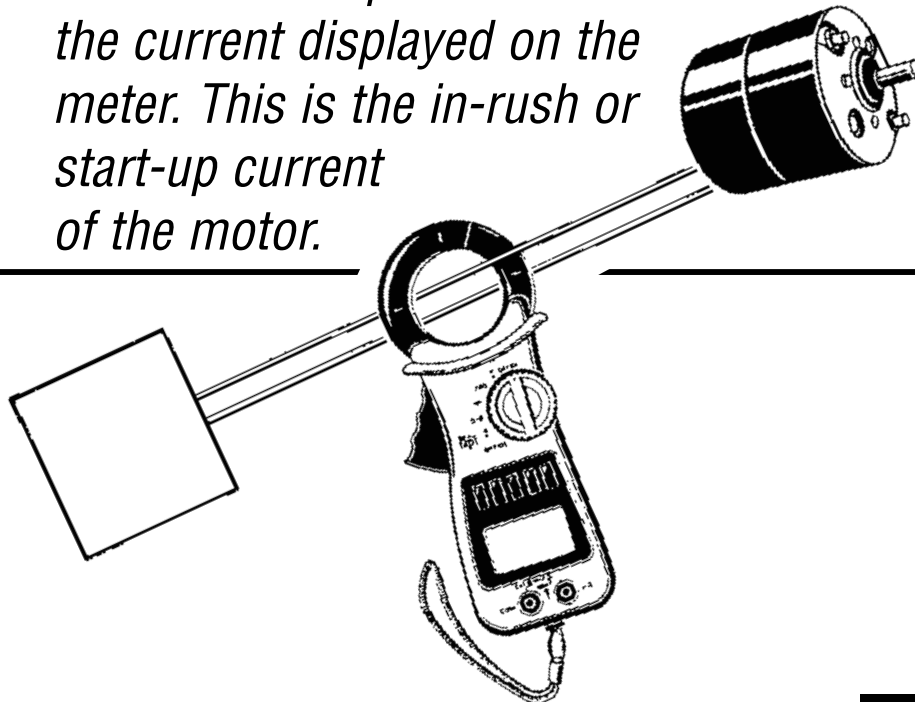

Application Notes (Temperature Differential)

When measuring temperature there may be applications when knowing the differential between two measurements is required. This can be accomplished by following these steps.

- Remove the test leads from the input jacks. Insert the K-type thermocouple probe into the input jack on the 275. Set the 275 to the desired TEMP function.*
- Touch the temperature probe sensor to the device under test (T1).*
- When the reading stabilizes, press the REL button. The display will read "0" and T1 will be stored as the reference value that the next measurement will be made relative to.*
- Touch the temperature probe sensor to the device under test (T2).*
- The 275 will display the differential temperature $T2-T1$.*

G. Trouble Shooting

Problem

Probable Causes

Does not power up

- Dead or defective battery
- Broken wire from battery snap to PCB

Won't display DC microamp readings

- Open fuse
- Open test lead
- Improperly connected to circuit under test

All functions except ohms read high

- Very weak battery that will not turn on the low battery indicator on the LCD

AC Volts do not read

- Very weak battery that will not turn on the low battery indicator on the LCD

Non-Contact Voltage does not work

- The non-contact voltage feature works best when used to test a single wire. Make sure the arrow on the jaw is pointed at the wire.

The meter beeps when set on TEMP

- This is a reminder to remove the test leads and insert the temperature probe. If a probe is inserted, this is an indication the probe is open.

AC Amps does not read

- Make sure the jaw is clamped around a single wire and the device connected to the wire is turned on.

H. Maintenance

1. **Battery / Fuse Replacement:** The 275 will display a battery symbol when the internal 9 Volt battery needs replacement. If DC microamps does not operate correctly the 0.5A / 600V fuse needs to be replaced. The battery or fuse is replaced as follows:
 - a. Disconnect and remove all test leads from live circuits and from the 275.
 - b. Loosen the screw from the back of the 275 battery / fuse cover.
 - c. Remove the battery / fuse compartment cover.
 - d. Remove old battery or fuse and replace with new battery or fuse. Observe the correct polarity on the battery. Only install the correct value fuse (0.5A/600V). Failure to do so can result in instrument damage.
 - e. Reassemble the instrument in reverse order from above.

2. **Cleaning your 275:**

Use a mild detergent and slightly damp cloth to clean the surfaces of the 275.

Accessories

Standard Accessories

9 Volt Alkaline Battery
Test Lead Set (1000V CATIII 10A)
0.5A / 600V Fuse
Soft Carrying Pouch

Part Number

A009A
A085
A107
A275

Optional Accessories

Fused Test Lead Kit
Deluxe Test Lead Set
Carbon Monoxide Adapter
Pressure Adapter

Part Number

FTLK3
TLS2000RB
A771
A620

275 SPECIFICATIONS (PARTIAL LIST)

±0.5% Basic DCV Accuracy (also see pages 8-11)

<u>Func.</u>	<u>Range</u>	<u>Res.</u>
DCV	1100mV	0.01mV
	1V	0.0001V
	11V	0.001V
	110V	0.01V
	600V	0.1V
ACV	110mV	0.01mV
	1V	0.0001V
	11V	0.001V
	100V	0.01V
	600V	0.1V
ACA/DCA	110A	0.01A
	400A	0.1A
OHM	110Ω	0.01Ω
	1.1kΩ	0.0001kΩ
	11kΩ	0.001kΩ
	110kΩ	0.01kΩ
	1.1MΩ	0.0001MΩ
	11MΩ	0.001MΩ
	111MΩ	0.01MΩ
DCuA	110uA	0.01uA
	1100uA	0.1uA
TEMP	-30°F to 1000°F	0.1°F



Test Products International, Inc.

9615 SW Allen Blvd., Ste. 104

Beaverton, OR USA 97005

503-520-9197 • Fax: 503-520-1225

info@tpi-thevalueleader.com

L275M • 1/25/05 copyright © 2005 Test Products International, Inc.