

MT9P401



5-Megapixel
1/2.5-Inch
CMOS Image Sensor
Die or 48-Pin iLCC

Ultra-Fast, High-Quality HD Video

1 HD Video at Fast Frame Rates

Speed is the key to capturing stunning 1080p HD video at 30 fps and 720p HD video at 60 fps.

2 Unparalleled Video Image Quality

Vivid HD video quality along with clear and brilliant still images for consumer-class camcorders.

3 Small Footprint, Simple Design

The 12-bit ADC for high-resolution image capture and HDTV video formats is a one-chip solution that enables a small footprint and easy design.

4 Fast Response Times and Short Focus Times

15 fps image capture at full resolution provides specialized high-speed DSC performance that can't be matched by CCDs.

5 Low Power Consumption

Low power advantages of CMOS technology extend the life of a DSC/DVC battery.

Applications

- Digital video cameras
- HD hybrid cameras
- Digital still cameras

How to Buy



Production and sample quantities of Micron products may be ordered through qualified distributors. See our Web site for details. You may also request access to NDA data sheets and other technical documentation by visiting our Web site.



MT9P401

Features

- Ultra-fast frame rate for high-quality HD video
- Vivid HD video quality and clear and brilliant still images
- High-quality 2.2µm pixel with DigitalClarity® CMOS imaging technology
- Low-power, progressive scan CMOS image sensor
- 5-megapixel resolution (2,592H x 1,944V)
- High-definition video capture
- Viewfinder, bulb, and snapshot modes
- On-chip, 12-bit analog-to-digital converter (ADC)
- Excellent low-light sensitivity
- Programmable gain and exposure control
- Two-wire serial interface
- Global reset
- Binning for enhanced viewing experience
- Phase-lock loop (PLL) for versatile clock in scheme

Specifications

Imaging Array

- Optical Format: 1/2.5-inch
- Active Array: 2,592(H) x 1,944(V)

Speed/Output

- Imaging Area: 5.70mm(H) x 4.28mm(V)
- Frame Rate: 15 fps @ full resolution (5Mp)
30 fps @ 1,080p
60 fps @ 720p

- Data Rate: 96 Mp/s
- Master Clock: 96 MHz
- Data Format: 12-bit progressive scan

Sensitivity

- Pixel Size: 2.2µm x 2.2µm
- Dynamic Range: 70dB
- Responsivity: 1.4 V/lux-sec (550nm)

Power

- Supply: Analog: 2.6–3.1V (2.8V nominal)
Digital: 1.7–1.9V (1.8V nominal)
I/O: 1.7–3.1V
- Consumption: 381mW @ full resolution

Temperature Range

- Operating: –30°C to +70°C

Package: Die, 48-pin iLCC

Block Diagram

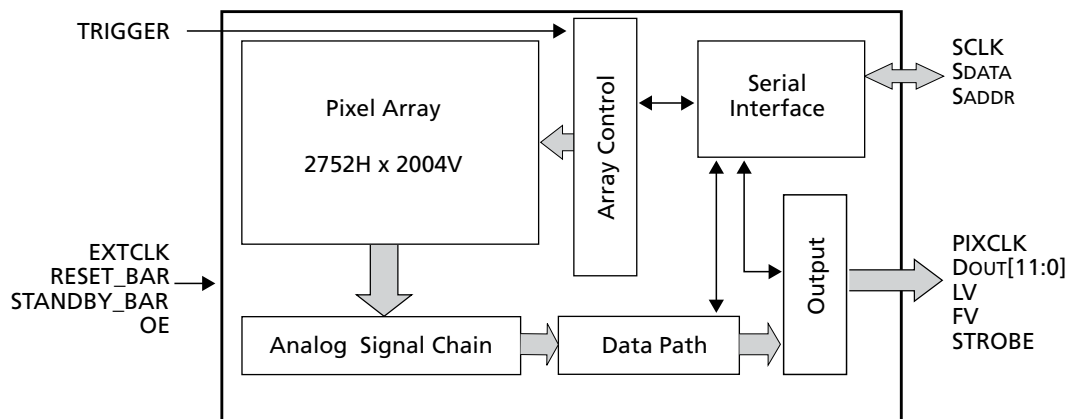

micron.com

Products are warranted only to meet Micron's production data sheet specifications. Products and specifications are subject to change without notice. Micron, the Micron logo, and DigitalClarity are trademarks of Micron Technology, Inc. All other trademarks are the property of their respective owners. ©2008 Micron, Inc. All rights reserved. 01/08 EN.L

