

**Features and Benefits**

Absolute 3D Position Sensor  
Simple & Robust Magnetic Design  
Tria<sup>⊗</sup>is™ Hall Technology  
Programmable Linear Transfer Characteristics (Alpha, Beta)  
Selectable Analog (Ratiometric), PWM, Serial Protocol  
12 bit Angular Resolution - 10 bit Angular Thermal Accuracy  
40 bit ID Number  
Single Die – SO8 Package RoHS Compliant  
Dual Die (Full Redundant) – TSSOP16 Package RoHS Compliant



**Applications**

3D Position Sensor	Joystick
4-Way Scroll Key	Joypad
Man Machine Interface Device	Linear Position Sensor

### Ordering Information<sup>1</sup>

Part No.	Temperature Suffix	Package Code	Die Rev.	Option code	Packing <sup>2</sup>
MLX90333	S (-20°C to 85°C)	DC [SOIC-8]	BCH	STANDARD <sup>3</sup>	Reel
MLX90333	E (-40°C to 85°C)	DC [SOIC-8]	BCH	STANDARD <sup>3</sup>	Reel
MLX90333	K (-40°C to 125°C)	DC [SOIC-8]	BCH	STANDARD <sup>3</sup>	Reel
MLX90333	L (-40°C to 150°C)	DC [SOIC-8]	BCH	STANDARD <sup>3</sup>	Reel
MLX90333	E (-40°C to 85°C)	GO [TSSOP-16]	BCH	STANDARD <sup>3</sup>	Reel
MLX90333	K (-40°C to 125°C)	GO [TSSOP-16]	BCH	STANDARD <sup>3</sup>	Reel
MLX90333	L (-40°C to 150°C)	GO [TSSOP-16]	BCH	STANDARD <sup>3</sup>	Reel
MLX90333	E (-40°C to 85°C)	DC [SOIC-8]	BCH	IP1 <sup>4</sup>	Reel
MLX90333	K (-40°C to 125°C)	DC [SOIC-8]	BCH	IP1 <sup>4</sup>	Reel
MLX90333	L (-40°C to 150°C)	DC [SOIC-8]	BCH	IP1 <sup>4</sup>	Reel
MLX90333	E (-40°C to 85°C)	GO [TSSOP-16]	BCH	IP1 <sup>4</sup>	Reel
MLX90333	K (-40°C to 125°C)	GO [TSSOP-16]	BCH	IP1 <sup>4</sup>	Reel
MLX90333	L (-40°C to 150°C)	GO [TSSOP-16]	BCH	IP1 <sup>4</sup>	Reel
MLX90333	E (-40°C to 85°C)	DC [SOIC-8]	BCH	SPI <sup>5</sup>	Reel
MLX90333	K (-40°C to 125°C)	DC [SOIC-8]	BCH	SPI <sup>5</sup>	Reel
MLX90333	L (-40°C to 150°C)	DC [SOIC-8]	BCH	SPI <sup>5</sup>	Reel
MLX90333	E (-40°C to 85°C)	GO [TSSOP-16]	BCH	SPI <sup>5</sup>	Reel
MLX90333	K (-40°C to 125°C)	GO [TSSOP-16]	BCH	SPI <sup>5</sup>	Reel
MLX90333	L (-40°C to 150°C)	GO [TSSOP-16]	BCH	SPI <sup>5</sup>	Reel
MLX90333	E (-40°C to 85°C)	DC [SOIC-8]	BCT	STANDARD <sup>3</sup>	Reel
MLX90333	K (-40°C to 125°C)	DC [SOIC-8]	BCT	STANDARD <sup>3</sup>	Reel
MLX90333	L (-40°C to 150°C)	DC [SOIC-8]	BCT	STANDARD <sup>3</sup>	Reel
MLX90333	E (-40°C to 85°C)	GO [TSSOP-16]	BCT	STANDARD <sup>3</sup>	Reel
MLX90333	K (-40°C to 125°C)	GO [TSSOP-16]	BCT	STANDARD <sup>3</sup>	Reel
MLX90333	L (-40°C to 150°C)	GO [TSSOP-16]	BCT	STANDARD <sup>3</sup>	Reel
MLX90333	E (-40°C to 85°C)	DC [SOIC-8]	BCT	IP1 <sup>4</sup>	Reel
MLX90333	K (-40°C to 125°C)	DC [SOIC-8]	BCT	IP1 <sup>4</sup>	Reel
MLX90333	L (-40°C to 150°C)	DC [SOIC-8]	BCT	IP1 <sup>4</sup>	Reel
MLX90333	E (-40°C to 85°C)	GO [TSSOP-16]	BCT	IP1 <sup>4</sup>	Reel
MLX90333	K (-40°C to 125°C)	GO [TSSOP-16]	BCT	IP1 <sup>4</sup>	Reel
MLX90333	L (-40°C to 150°C)	GO [TSSOP-16]	BCT	IP1 <sup>4</sup>	Reel

<sup>1</sup> Example: MLX90333KDC-BCH-STANDARD-Reel

<sup>2</sup> For engineering purpose, a limited number of samples can also be ordered in tubes. In this case, the value "Reel" in the field "Packing" must be replaced by "Tube".

<sup>3</sup> Fully end-user programmable version through the Melexis Programming Unit PTC-04

<sup>4</sup> See your sales representative for more details.

<sup>5</sup> Pre-Programmed SPI, locked for 180deg Joystick application (Alpha, Beta).

### 1. Functional Diagram

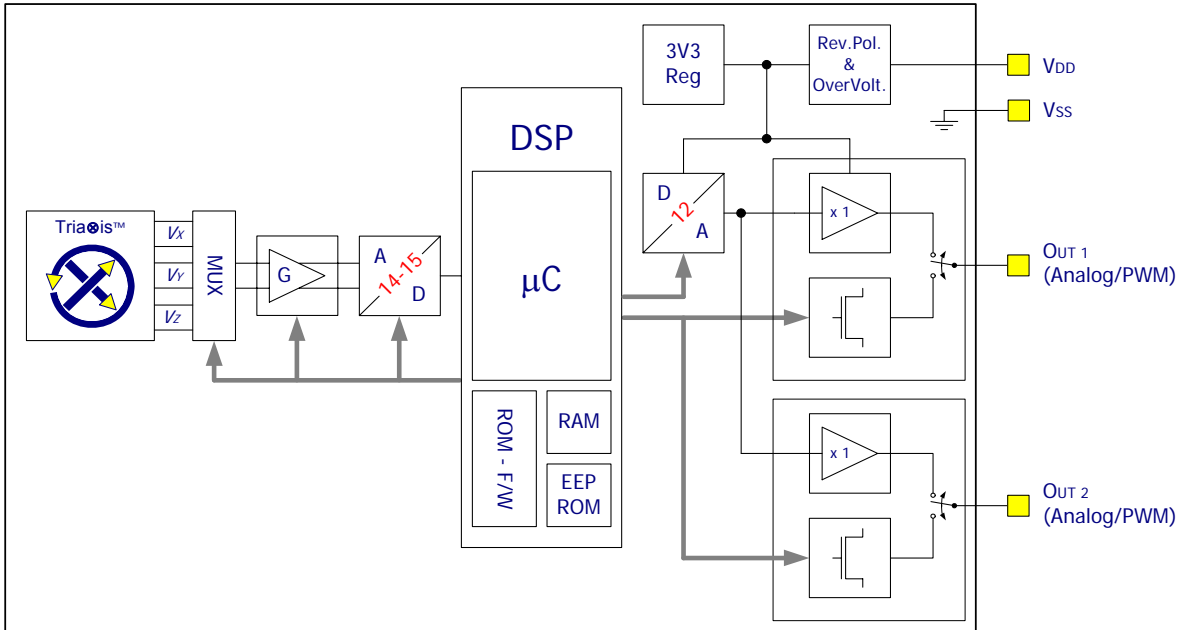

Figure 1 - Block Diagram (Analog & PWM)

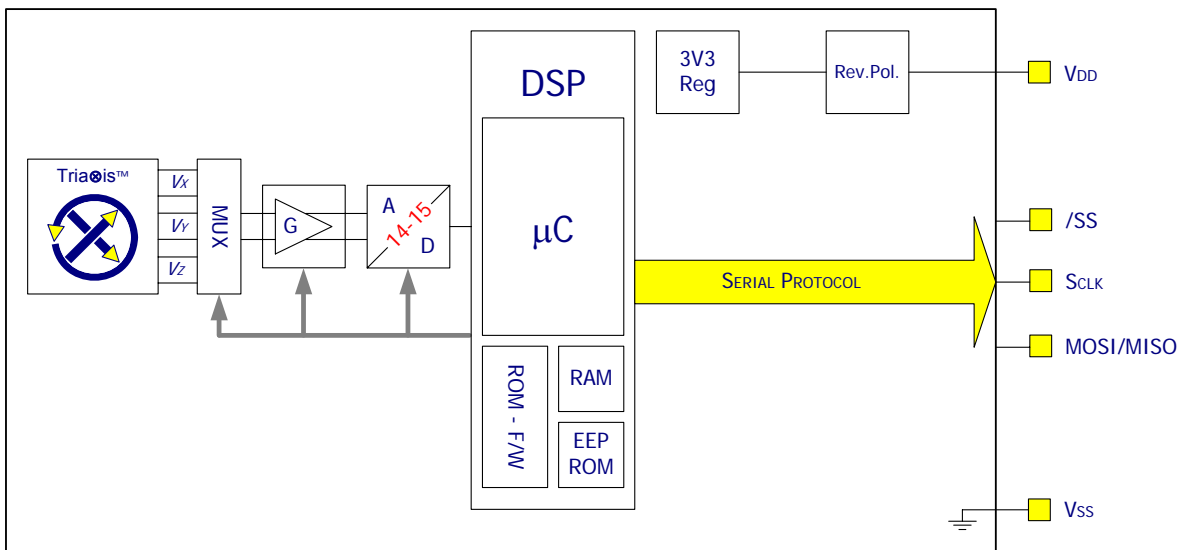

Figure 2 - Block Diagram (Serial Protocol)

## 2. Description

The MLX90333 is a monolithic sensor IC featuring the Tria $\otimes$ is™ Hall technology. Conventional planar Hall technology is only sensitive to the flux density applied orthogonally to the IC surface. The Tria $\otimes$ is™ Hall sensor is also sensitive to the flux density applied parallel to the IC surface. This is obtained through an Integrated Magneto-Concentrator (IMC $\otimes$ ) which is deposited on the CMOS die (as an additional back-end step).

The MLX90333 is sensitive to the 3 components of the flux density applied to the IC ( $B_x$ ,  $B_y$  and  $B_z$ ). This allows the MLX90333 to sense any magnet moving in its surrounding and it enables the design of novel generation of non-contacting joystick position sensors which are often required for both automotive and industrial applications (e.g. man-machine interface).

Furthermore, the capability of measuring  $B_x$ ,  $B_y$  and  $B_z$  allows the MLX90333 to be considered as universal non-contacting position sensor i.e. not limited to joystick applications. For instance, a linear travel can be sensed with the MLX90333 once included in a specific magnetic design.

In combination with the appropriate signal processing, the magnetic flux density of a small magnet (axial magnetization) moving above the IC can be measured in a non-contacting way (Figure 3). The two (2) angular information are computed from the three (3) vector components of the flux density (i.e.  $B_x$ ,  $B_y$  and  $B_z$ ). MLX90333 reports two (2) linear output signals. The output formats are selectable between Analog, PWM and Serial Protocol.



Figure 3 - Typical application of MLX90333

**TABLE of CONTENTS**

<b>FEATURES AND BENEFITS .....</b>	<b>1</b>
<b>APPLICATIONS.....</b>	<b>1</b>
<b>ORDERING INFORMATION.....</b>	<b>2</b>
<b>1. FUNCTIONAL DIAGRAM.....</b>	<b>3</b>
<b>2. DESCRIPTION.....</b>	<b>4</b>
<b>3. GLOSSARY OF TERMS – ABBREVIATIONS – ACRONYMS .....</b>	<b>7</b>
<b>4. PINOUT .....</b>	<b>7</b>
<b>5. ABSOLUTE MAXIMUM RATINGS .....</b>	<b>8</b>
<b>6. DETAILED DESCRIPTION.....</b>	<b>8</b>
<b>7. MLX90333 ELECTRICAL SPECIFICATION.....</b>	<b>14</b>
<b>8. MLX90333 ISOLATION SPECIFICATION .....</b>	<b>16</b>
<b>9. MLX90333 TIMING SPECIFICATION .....</b>	<b>16</b>
<b>10. MLX90333 ACCURACY SPECIFICATION .....</b>	<b>17</b>
<b>11. MLX90333 MAGNETIC SPECIFICATION .....</b>	<b>18</b>
<b>12. MLX90333 CPU &amp; MEMORY SPECIFICATION .....</b>	<b>18</b>
<b>13. MLX90333 END-USER PROGRAMMABLE ITEMS.....</b>	<b>19</b>
<b>14. DESCRIPTION OF END-USER PROGRAMMABLE ITEMS.....</b>	<b>21</b>
14.1. OUTPUT CONFIGURATION .....	21
14.2. OUTPUT MODE.....	21
14.2.1. <i>Analog Output Mode</i> .....	21
14.2.2. <i>PWM Output Mode</i> .....	21
14.2.3. <i>Serial Protocol Output Mode</i> .....	22
14.2.4. <i>Switch Out</i> .....	22
14.3. OUTPUT TRANSFER CHARACTERISTIC.....	22
14.3.1. <i>The Polarity and Modulo Parameters</i> .....	23
14.3.2. <i>Alpha/Beta Discontinuity Point (or Zero Degree Point)</i> .....	24
14.3.3. <i>LNR Parameters</i> .....	24
14.3.4. <i>CLAMPING Parameters</i> .....	25
14.3.5. <i>DEADZONE Parameter</i> .....	25
14.4. IDENTIFICATION .....	26
14.5. SENSOR FRONT-END .....	26
14.5.1. <i>HIGHSPEED Parameter</i> .....	26
14.5.2. <i>GAINMIN and GAINMAX Parameters</i> .....	26
14.5.3. <i>FIELDTHRES_LOW and FIELDTHRES_HIGH Parameters</i> .....	26
14.6. FILTER .....	27
14.6.1. <i>Hysteresis Filter</i> .....	27
14.6.2. <i>FIR Filters</i> .....	27
14.6.3. <i>IIR Filters</i> .....	28

14.7.	PROGRAMMABLE ENHANCED “JOYSTICK” ANGLE CORRECTION.....	29
14.7.1.	<i>Enhanced “Joystick “Angle Formula.....</i>	30
14.8.	PROGRAMMABLE DIAGNOSTIC SETTINGS .....	30
14.8.1.	<i>OUTxDIAG Parameter.....</i>	30
14.8.2.	<i>RESONFAULT Parameter .....</i>	30
14.8.3.	<i>EEHAMHOLE Parameter.....</i>	30
14.9.	LOCK.....	31
14.9.1.	<i>MLXLOCK Parameter .....</i>	31
14.9.2.	<i>LOCK Parameter .....</i>	31
<b>15.</b>	<b>MLX90333 SELF DIAGNOSTIC.....</b>	<b>32</b>
<b>16.</b>	<b>SERIAL PROTOCOL.....</b>	<b>34</b>
16.1.	INTRODUCTION .....	34
16.2.	SERIAL PROTOCOL MODE .....	34
16.3.	MOSI (MASTER OUT SLAVE IN) .....	34
16.4.	MISO (MASTER IN SLAVE OUT) .....	34
16.5.	/SS (SLAVE SELECT) .....	34
16.6.	MASTER START-UP.....	34
16.7.	SLAVE START-UP.....	34
16.8.	TIMING.....	35
16.9.	SLAVE RESET .....	36
16.10.	FRAME LAYER .....	36
16.10.1.	<i>Frame Type Selection.....</i>	36
16.10.2.	<i>Data Frame Structure .....</i>	36
16.10.3.	<i>Timing .....</i>	36
16.10.4.	<i>Data Structure .....</i>	37
16.10.5.	<i>Angle Calculation.....</i>	37
16.10.6.	<i>Error Handling.....</i>	37
<b>17.</b>	<b>RECOMMENDED APPLICATION DIAGRAMS .....</b>	<b>38</b>
17.1.	ANALOG OUTPUT WIRING WITH THE MLX90333 IN SOIC PACKAGE.....	38
17.2.	PWM LOW SIDE OUTPUT WIRING .....	38
17.3.	ANALOG OUTPUT WIRING WITH THE MLX90333 IN TSSOP PACKAGE.....	39
17.4.	SERIAL PROTOCOL .....	39
<b>18.</b>	<b>STANDARD INFORMATION REGARDING MANUFACTURABILITY OF MELEXIS PRODUCTS WITH DIFFERENT SOLDERING PROCESSES .....</b>	<b>41</b>
<b>19.</b>	<b>ESD PRECAUTIONS.....</b>	<b>41</b>
<b>20.</b>	<b>PACKAGE INFORMATION.....</b>	<b>42</b>
20.1.	SOIC8 - PACKAGE DIMENSIONS .....	42
20.2.	SOIC8 - PINOUT AND MARKING .....	42
20.3.	SOIC8 - IMC POSITIONNING.....	43
20.4.	TSSOP16 - PACKAGE DIMENSIONS.....	44
20.5.	TSSOP16 - PINOUT AND MARKING .....	45
20.6.	TSSOP16 - IMC POSITIONNING.....	45
<b>21.</b>	<b>DISCLAIMER .....</b>	<b>46</b>

### 3. Glossary of Terms – Abbreviations – Acronyms

- Gauss (G), Tesla (T): Units for the magnetic flux density – 1 mT = 10 G
- TC: **T**emperature **C**oefficient (in ppm/Deg.C.)
- NC: **N**ot **C**onnected
- PWM: **P**ulse **W**idth **M**odulation
- %DC: **D**uty **C**ycle of the output signal i.e.  $T_{ON} / (T_{ON} + T_{OFF})$
- ADC: **A**nalog-to-**D**igital **C**onverter
- DAC: **D**igital-to-**A**nalog **C**onverter
- LSB: **L**east **S**ignificant **B**it
- MSB: **M**ost **S**ignificant **B**it
- DNL: **D**ifferential **N**on-**L**inearity
- INL: **I**ntegral **N**on-**L**inearity
- RISC: **R**educed **I**nstruction **S**et **C**omputer
- ASP: **A**nalog **S**ignal **P**rocessing
- DSP: **D**igital **S**ignal **P**rocessing
- ATAN: trigonometric function: arctangent (or inverse tangent)
- IMC: **I**ntegrated **M**agneto-**C**oncentrator (IMC<sup>®</sup>)
- CoRDIC: **C**oordinate **R**otation **D**igital **C**omputer (i.e. iterative rectangular-to-polar transform)
- EMC: **E**lectro-**M**agnetic **C**ompatibility

### 4. Pinout<sup>6</sup>

Pin #	SOIC-8		TSSOP-16	
	Analog / PWM	Serial Protocol	Analog / PWM	Serial Protocol
1	VDD	VDD	VDIG <sub>1</sub>	VDIG <sub>1</sub>
2	Test 0	Test 0	VSS <sub>1</sub> (Ground <sub>1</sub> )	VSS <sub>1</sub> (Ground <sub>1</sub> )
3	Not Used	/SS	VDD <sub>1</sub>	VDD <sub>1</sub>
4	Out 2	SCLK	Test 0 <sub>1</sub>	Test 0 <sub>1</sub>
5	Out 1	MOSI / MISO	Not Used	/SS <sub>2</sub>
6	Test 1	Test 1	Out 2 <sub>2</sub>	SCLK <sub>2</sub>
7	VDIG	VDIG	Out 1 <sub>2</sub>	MOSI <sub>2</sub> / MISO <sub>2</sub>
8	VSS (Ground)	VSS (Ground)	Test 1 <sub>2</sub>	Test 1 <sub>2</sub>
9			VDIG <sub>2</sub>	VDIG <sub>2</sub>
10			VSS <sub>2</sub> (Ground <sub>2</sub> )	VSS <sub>2</sub> (Ground <sub>2</sub> )
11			VDD <sub>2</sub>	VDD <sub>2</sub>
12			Test 0 <sub>2</sub>	Test 0 <sub>2</sub>
13			Not Used	/SS <sub>1</sub>
14			Out 2 <sub>1</sub>	SCLK <sub>1</sub>
15			Out 1 <sub>1</sub>	MOSI <sub>1</sub> / MISO <sub>1</sub>
16			Test 1 <sub>1</sub>	Test 1 <sub>1</sub>

For optimal EMC behavior, it is recommended to connect the unused pins (Not Used and Test) to the Ground (see section 16).

<sup>6</sup> See Section 14.1 for the Out 1 and Out 2 configuration

## 5. Absolute Maximum Ratings

Parameter	Value
Supply Voltage, VDD (overvoltage)	+ 20 V
Reverse Voltage Protection	- 10 V
Positive Output Voltage (Analog or PWM) Both outputs OUT 1 & OUT 2	+ 10 V + 14 V (200 s max - T <sub>A</sub> = + 25°C)
Output Current (I <sub>OUT</sub> )	± 30 mA
Reverse Output Voltage Both outputs OUT 1 & OUT 2	- 0.3 V
Reverse Output Current Both outputs OUT 1 & OUT 2	- 50 mA
Operating Ambient Temperature Range, T <sub>A</sub>	- 40°C ... + 150°C
Storage Temperature Range, T <sub>S</sub>	- 40°C ... + 150°C
Magnetic Flux Density	± 4 T

Exceeding the absolute maximum ratings may cause permanent damage. Exposure to absolute-maximum-rated conditions for extended periods may affect device reliability.

## 6. Detailed Description

As described on the block diagram (Figure 1 and Figure 2), the magnetic flux density applied to the IC is sensed through the Tria $\otimes$ is™ sensor front-end. This front-end consists into two orthogonal pairs (for each of the two directions parallel with the IC surface i.e. X and Y) of conventional planar Hall plates (sensitive element – blue area on Figure 4) and an Integrated Magneto-Concentrator (IMC® yellow disk on Figure 4).

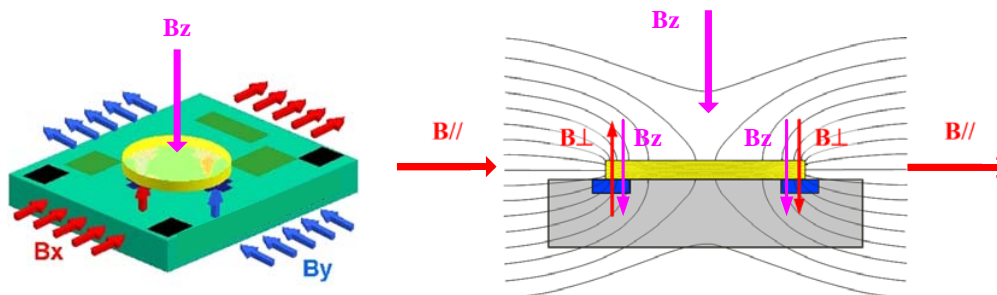

Figure 4 - Tria $\otimes$ is™ sensor front-end (4 Hall plates + IMC® disk)

Two orthogonal components (respectively  $B_{x\perp}$  and  $B_{y\perp}$ ) proportional to the parallel components (respectively  $B_{x//}$  and  $B_{y//}$ ) are induced through the IMC and can be measured by both respective pairs of conventional planar Hall plates as those are sensitive to the flux density applied orthogonally to them and the IC surface. The third component  $B_z$  is also sensed by those four (4) conventional Hall plates as shown above.



In summary, along X-axis, the left Hall plate measures “ $B_{X\perp} - B_z$ ” while the right Hall plate measures “ $-B_{X\perp} - B_z$ ”. Similarly, along the Y-axis, the left Hall plate measures “ $B_{Y\perp} - B_z$ ” while the right Hall plate measures “ $-B_{Y\perp} - B_z$ ”.

Through an appropriate signal processing, the Tria $\otimes$ is™ sensor front-end reports the three (3) components of the applied magnetic flux density B i.e.  $B_x$ ,  $B_y$  and  $B_z$ .

Indeed, by subtracting the signals from the two (2) Hall plates in each pair, the components  $B_{X\perp}$  and  $B_{Y\perp}$  are measured while  $B_z$  is cancelled. To the contrary, by adding the signals from the two (2) Hall plates in each pair, the component  $B_z$  is measured while  $B_{X\perp}$  and  $B_{Y\perp}$  are cancelled

In a joystick based on a “gimbal” mechanism as shown on Figure 3 (left), the magnet (axial magnetization) moves on a hemisphere centered at the IC. The flux density is described through the following relationships:

$$B_x = \cos(\alpha) \cdot \sin(\beta)$$

$$B_y = \sin(\alpha) \cdot \cos(\beta)$$

$$B_z = \sin(\alpha) \cdot \sin(\beta)$$

Those components are plotted on the Figure 5, Figure 6 and Figure 7.

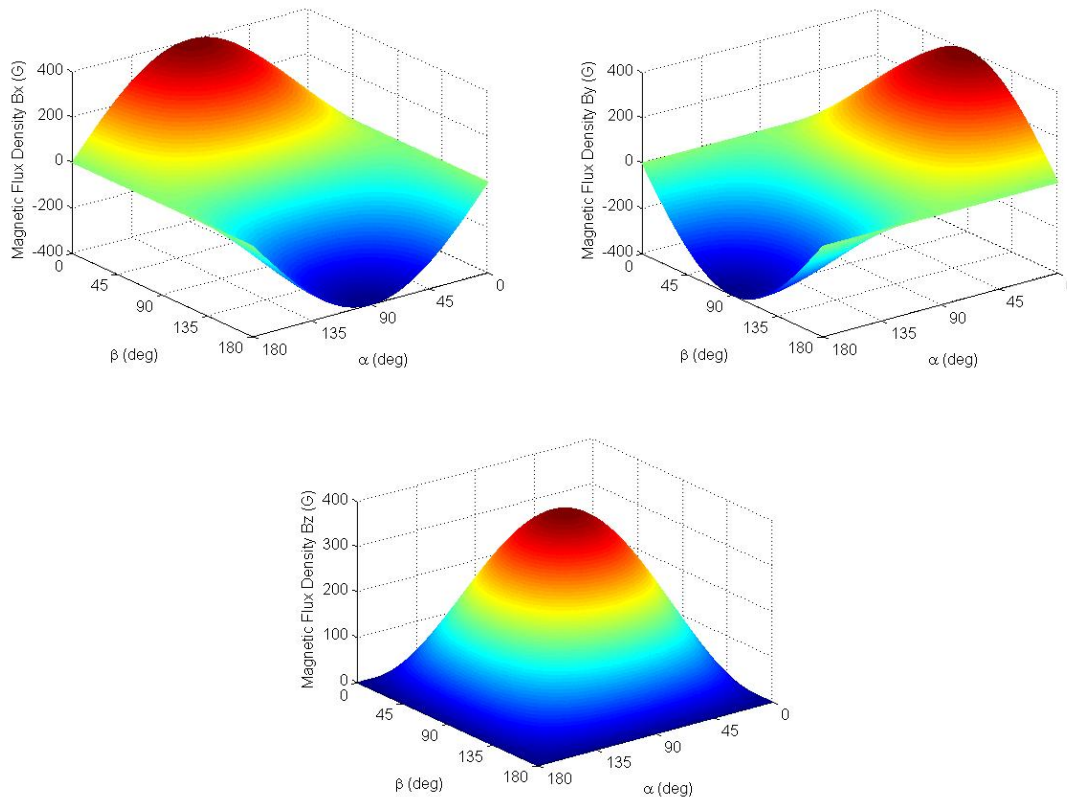

Figure 5 – Magnetic Flux Density –  $B_x$ ,  $B_y$ ,  $B_z$

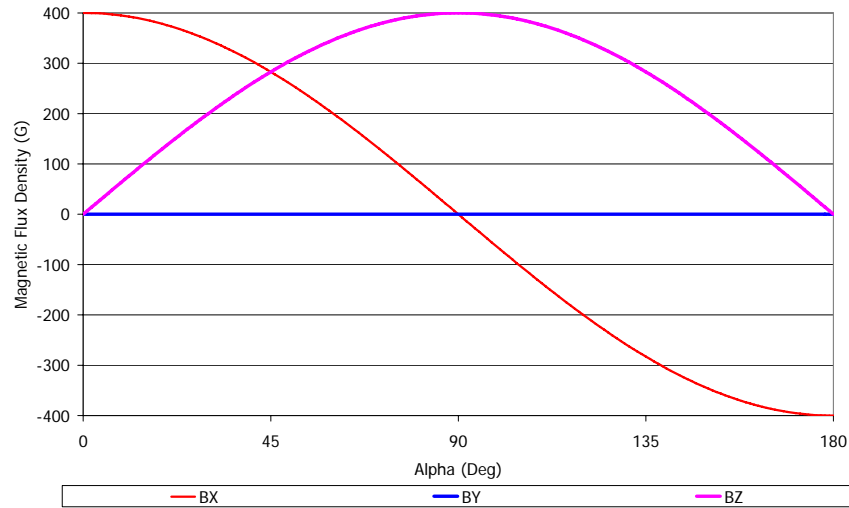

Figure 6 – Magnetic Flux Density –  $\beta = 90$  Deg –  $B_x \propto \cos(\alpha)$ ,  $B_y = 0$  &  $B_z \propto \sin(\alpha)$

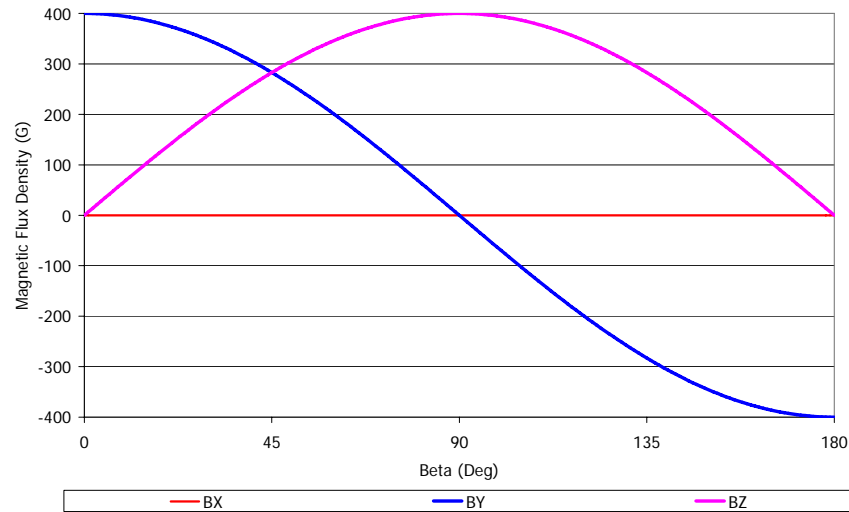

Figure 7 – Magnetic Flux Density –  $\alpha = 0$  Deg –  $B_x = 0$ ,  $B_y \propto \cos(\beta)$  &  $B_z \propto \sin(\beta)$

Three (3) differential voltages corresponding to the three (3) components of the applied flux density are provided to the ADC (Analog-to-Digital Converter – Figure 8 and Figure 9). The Hall signals are processed through a fully differential analog chain featuring the classic offset cancellation technique (Hall plate quadrature spinning and chopper-stabilized amplifier).

The amplitude of  $V_z$  is smaller than the other two (2) components  $V_x$  and  $V_y$  due to fact that the magnetic gain of the IMC only affects the components parallel to the IC surface.

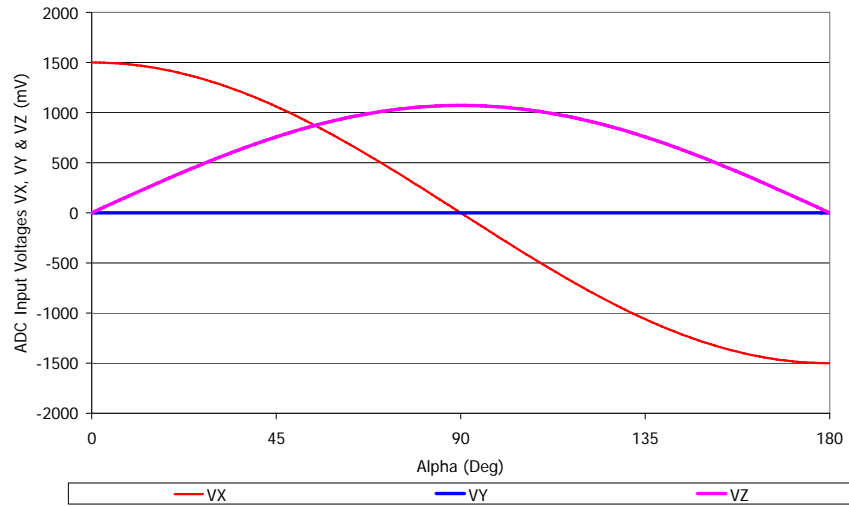

Figure 8 – ADC Input Signals –  $\beta = 90$  Deg –  $V_X \propto B_X \propto \cos(\alpha)$ ,  $V_Y = B_Y = 0$  &  $V_Z \propto B_Z \propto \sin(\alpha)$

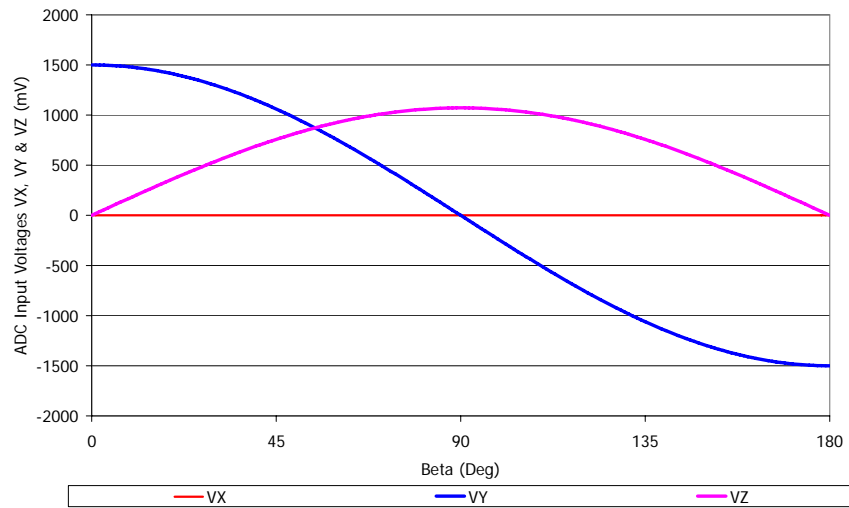

Figure 9 – ADC Input Signals –  $\alpha = 90$  Deg –  $V_X = B_X = 0$ ,  $V_Y \propto B_Y \propto \cos(\beta)$  &  $V_Z \propto B_Z \propto \sin(\beta)$

The conditioned analog signals are converted through an ADC (configurable – 14 or 15 bits) and provided to a DSP block for further processing. The DSP stage is based on a 16 bit RISC micro-controller whose primary function is the extraction of the two (2) angular information from the three (3) raw signals (after so-called front-end compensation steps) through the following operations:

$$\alpha = ATAN\left(\frac{k_z V_z}{V_x}\right)$$

$$\beta = ATAN\left(\frac{k_z V_z}{V_y}\right)$$

where  $k_z$  is a programmable parameter. First of all,  $k_z$  is used to compensate the smaller amplitude of  $V_z$  vs.  $V_x$  &  $V_y$ . On the other hand,  $k_z$  allows also a targeted reduction of the linearity error through a normalization of the raw signals prior to performing the “ATAN” function.

In a joystick based on a “ball & socket” joint as shown on Figure 3 (right), the magnet (axial magnetization) moves on a hemisphere centered at the pivot point. The flux density is described through slightly more complex equations but the MLX90333 offers an alternate algorithm to extract both angular informations:

$$\alpha = ATAN\left(\frac{\sqrt{(k_z V_z)^2 + (k_t V_y)^2}}{V_x}\right)$$

$$\beta = ATAN\left(\frac{\sqrt{(k_z V_z)^2 + (k_t V_x)^2}}{V_y}\right)$$

where  $k_z$  and  $k_t$  are programmable parameters.

The DSP functionality is governed by the micro-code (firmware – F/W) of the micro-controller which is stored into the ROM (mask programmable). In addition to the “ATAN” function, the F/W controls the whole analog chain, the output transfer characteristic, the output protocol, the programming/calibration and also the self-diagnostic modes.

In the MLX90333, the “ATAN” function is computed via a look-up table (i.e. it is not obtained through a CoRDic algorithm).

Due to the fact that the “ATAN” operation is performed on the ratios “ $V_z/V_x$ ” and “ $V_z/V_y$ ”, the angular information are intrinsically self-compensated vs. flux density variations (due to airgap change, thermal or ageing effects) affecting the magnetic signal. This feature allows therefore an improved thermal accuracy vs. joystick based on conventional linear Hall sensors.

Once the angular information is computed (over 360 degrees), it is further conditioned (mapped) vs. the target transfer characteristic and it is provided at the output(s) as:

- an analog output level through a 12 bit DAC followed by a buffer
- a digital PWM signal with 12 bit depth (programmable frequency 100 Hz ... 1 kHz)
- a digital Serial Protocol (SP – 16 bits computed angular information available)

For instance, the analog output can be programmed for offset, gain and clamping to meet any rotary position sensor output transfer characteristic:

$$\begin{array}{ll} V_{out}(\alpha) = \text{ClampLo} & \text{for } \alpha \leq \alpha_{\min} \\ V_{out}(\alpha) = V_{\text{offset}} + \text{Gain} \times \alpha & \text{for } \alpha_{\min} \leq \alpha \leq \alpha_{\max} \\ V_{out}(\alpha) = \text{ClampHi} & \text{for } \alpha \geq \alpha_{\max} \\ \\ V_{out}(\beta) = \text{ClampLo} & \text{for } \beta \leq \beta_{\min} \\ V_{out}(\beta) = V_{\text{offset}} + \text{Gain} \times \beta & \text{for } \beta_{\min} \leq \beta \leq \beta_{\max} \\ V_{out}(\beta) = \text{ClampHi} & \text{for } \beta \geq \beta_{\max} \end{array}$$

where  $V_{\text{offset}}$ ,  $\text{Gain}$ ,  $\text{ClampLo}$  and  $\text{ClampHi}$  are the main adjustable parameters for the end-user.

The linear part of the transfer curve can be adjusted through a 3 point calibration. Once only one output is used, a 5 point calibration is also available for further improvement of the linearity.

The calibration parameters are stored in EEPROM featuring a Hamming Error Correction Coding (ECC).

The programming steps do not require any dedicated pins. The operation is done using the supply and output nodes of the IC. The programming of the MLX90333 is handled at both engineering lab and production line levels by the Melexis Programming Unit PTC-04 with the MLX90316 daughterboard and dedicated software tools (DLL – User Interface).

## 7. MLX90333 Electrical Specification

DC Operating Parameters at VDD = 5V (unless otherwise specified) and for T<sub>A</sub> as specified by the Temperature suffix (K or L).

Parameter	Symbol	Test Conditions	Min	Typ	Max	Units
Nominal Supply Voltage	VDD		4.5	5	5.5	V
Supply Current <sup>(7)</sup>	I <sub>dd</sub>	Slow mode <sup>(8)</sup>		8.5	11	mA
		Fast mode <sup>(8)</sup>		13.5	16	mA
POR Level	VDD POR	Supply Under Voltage	2	2.7	3	V
Output Current Both outputs OUT 1 & OUT 2	I <sub>out</sub>	Analog Output mode	-8		8	mA
		PWM Output mode	-20		20	mA
Output Short Circuit Current Both outputs OUT 1 & OUT 2	I <sub>short</sub>	V <sub>out</sub> = 0 V		12	15	mA
		V <sub>out</sub> = 5 V		12	15	mA
		V <sub>out</sub> = 14 V (T <sub>A</sub> = 25°C)		24	45	mA
Output Load Both outputs OUT 1 & OUT 2	R <sub>L</sub>	Pull-down to Ground	1	10	∞ <sup>(10)</sup>	kΩ
		Pull-up to 5V <sup>(9)</sup>	1	10	∞ <sup>(10)</sup>	kΩ
Analog Saturation Output Level Both outputs OUT 1 & OUT 2	V <sub>sat_lo</sub>	Pull-up load R <sub>L</sub> ≥ 10 kΩ			3	%VDD
	V <sub>sat_hi</sub>	Pull-down load R <sub>L</sub> ≥ 5 kΩ	96			%VDD
Digital Saturation Output Level Both outputs OUT 1 & OUT 2	V <sub>satD_lo</sub>	Pull-up Low Side R <sub>L</sub> ≥ 10 kΩ Push-Pull (I <sub>OUT</sub> = -20mA)			1.5	%VDD
	V <sub>satD_hi</sub>	Push-Pull (I <sub>OUT</sub> = 20mA)	97			%VDD
Active Diagnostic Output Level Both outputs OUT 1 & OUT 2	Diag_lo	Pull-down load R <sub>L</sub> ≥ 5 kΩ Pull-up load R <sub>L</sub> ≥ 10 kΩ			1 1.5	%VDD
	Diag_hi	Pull-down load R <sub>L</sub> ≥ 5 kΩ Pull-up load R <sub>L</sub> ≥ 5 kΩ	96 98			%VDD
Passive Diagnostic Output Level Both outputs OUT 1 & OUT 2 (Broken Track Diagnostic) <sup>(11)</sup>	BV <sub>ssPD</sub>	Broken V <sub>SS</sub> & Pull-down load R <sub>L</sub> ≤ 10 kΩ			4 <sup>(11)</sup>	%VDD
	BV <sub>ssPU</sub>	Broken V <sub>SS</sub> <sup>(11)</sup> & Pull-up load R <sub>L</sub> ≥ 1kΩ	99	100		%VDD
	BV <sub>DDPD</sub>	Broken V <sub>DD</sub> <sup>(11)</sup> & Pull-down load R <sub>L</sub> ≥ 1kΩ		0	1	%VDD
	BV <sub>DDPU</sub>	Broken V <sub>DD</sub> & Pull-up load to 5V	No Broken Track diagnostic			%VDD
Clamped Output Level Both outputs OUT 1 & OUT 2	Clamp_lo	Programmable	0		100	%VDD <sup>(12)</sup>
	Clamp_hi	Programmable	0		100	%VDD <sup>(12)</sup>

<sup>7</sup> For the dual version, the supply current is multiplied by 2

<sup>8</sup> See section 14.5.1 for details concerning Slow and Fast mode

<sup>9</sup> Applicable for output in Analog and PWM (Open-Drain) modes

<sup>10</sup> R<sub>L</sub> < ∞ for output in PWM mode

<sup>11</sup> For detailed information, see also section 15

<sup>12</sup> Clamping levels need to be considered vs the saturation of the output stage (see V<sub>sat\_lo</sub> and V<sub>sat\_hi</sub>)

As an illustration of the previous table, the MLX90333 fits the typical classification of the output span described on the Figure 10.

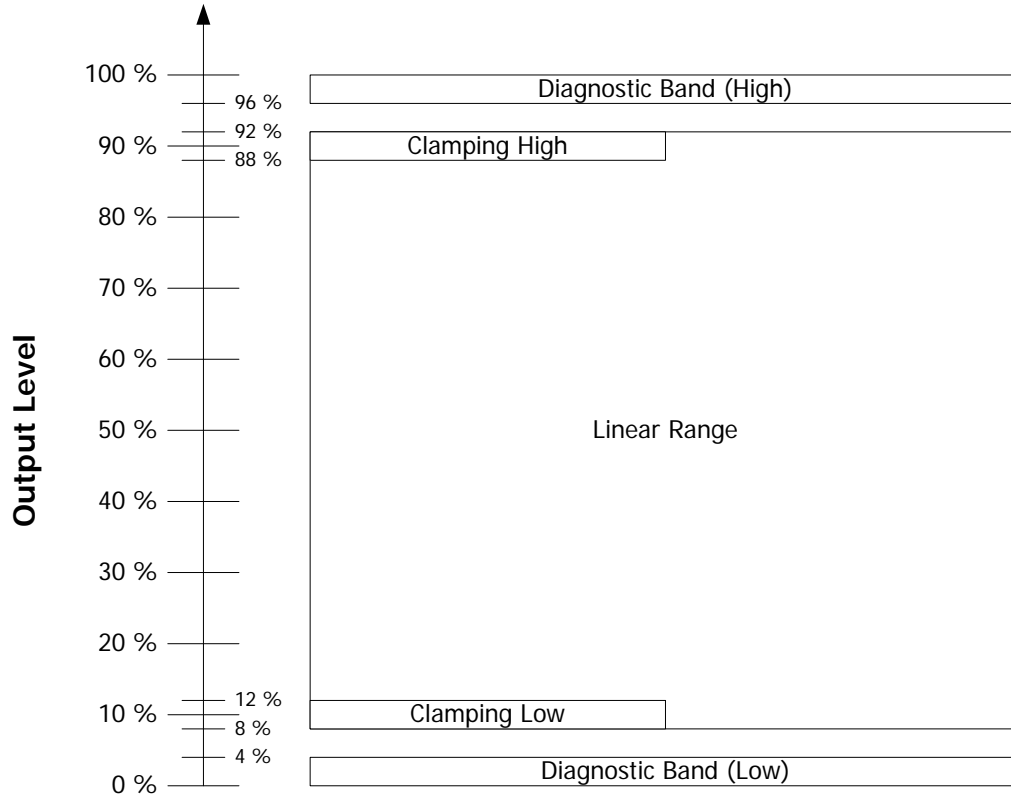

Figure 10 - Output Span Classification

## 8. MLX90333 Isolation Specification

DC Operating Parameters at  $V_{DD} = 5V$  (unless otherwise specified) and for  $T_A$  as specified by the Temperature suffix (K or L). Only valid for the package code GO i.e. dual die version.

Parameter	Symbol	Test Conditions	Min	Typ	Max	Units
Isolation Resistance		Between 2 dies	4			MΩ

## 9. MLX90333 Timing Specification

DC Operating Parameters at  $V_{DD} = 5V$  (unless otherwise specified) and for  $T_A$  as specified by the Temperature suffix (K or L).

Parameter	Symbol	Test Conditions	Min	Typ	Max	Units	
Main Clock Frequency	Ck	Slow mode <sup>(13)</sup>		7		MHz	
		Fast mode <sup>(13)</sup>		20		MHz	
Sampling Rate	C <sub>T</sub>	Slow mode <sup>(13)</sup>		600	1000	μs	
		Fast mode <sup>(13)</sup>		200	330	μs	
Step Response Time	T <sub>s</sub>	Slow mode <sup>(13)</sup> , Filter=5 <sup>(14)</sup>			4	ms	
		Fast mode <sup>(13)</sup> , Filter=0 <sup>(14)</sup>		400	600	μs	
Watchdog	Wd	See Section 15			5	ms	
Start-up Cycle	T <sub>su</sub>	Slow and Fast mode <sup>(13)</sup>			15	ms	
Analog Output Slew Rate		C <sub>OUT</sub> = 42 nF		200		V/ms	
		C <sub>OUT</sub> = 100 nF		100			
PWM Frequency	F <sub>PWM</sub>	PWM Output Enabled	100		1000	Hz	
Digital Output Rise Time Both outputs OUT 1 & OUT 2		Mode 5 – 10nF, R <sub>L</sub> = 10 kΩ		120		μs	
		Mode 7 – 10nF, R <sub>L</sub> = 10 kΩ		2.2		μs	
Digital Output Fall Time Both outputs OUT 1 & OUT 2		Mode 5 – 10nF, R <sub>L</sub> = 10 kΩ		1.8		μs	
		Mode 7 – 10nF, R <sub>L</sub> = 10 kΩ		1.9		μs	
Maximum Field amplitude Change <sup>(15)</sup> (%) vs. Field Frequency(Hz)		AGC 90% <sup>(16)</sup>					
		Slow mode <sup>(13)</sup> - Field Freq> 40Hz	-10		10	%	
		Field Freq= 20Hz	-30		30	%	
		Fast mode <sup>(13)</sup> -Field Freq> 150Hz	-12		12	%	
		Field Freq= 50Hz	-30		30	%	
		AGC 64% (90333BCT only)					
		Slow mode <sup>(13)</sup> -Field Freq> 80Hz	-22		22	%	
		Field Freq=50Hz	-30		30	%	
Fast mode <sup>(13)</sup> - Field Freq> 250Hz	-30		30	%			
Field Freq=50Hz	-60		60	%			

<sup>13</sup> See section 14.5.1 for details concerning Slow and Fast mode

<sup>14</sup> See section 14.6 for details concerning Filter parameter

<sup>15</sup> Ex.: Magnetic field amplitude change in case of vibration.

<sup>16</sup> Automatic Gain Control – see Section 14.5.2 for more information.



## 10. MLX90333 Accuracy Specification

DC Operating Parameters at  $V_{DD} = 5V$  (unless otherwise specified) and for  $T_A$  as specified by the Temperature suffix (K or L).

Parameter	Symbol	Test Conditions	Min	Typ	Max	Units
ADC Resolution on the raw signals X, Y and Z	$R_{ADC}$	Slow Mode <sup>(17)</sup>		15		bits
		Fast Mode <sup>(17)</sup>		14		bits
Offset on the Raw Signals X, Y and Z	$X_0, Y_0, Z_0$	$T_A = 25^\circ C$	-60		60	LSB <sub>15</sub>
Mismatch on the Raw Signals X, Y and Z	$SMISM_{XY}$ $SMISM_{XZ}$ $SMISM_{YZ}$	$T_A = 25^\circ C$ Between X and Y	-1		1	%
		Between X and Z <sup>(18)</sup>	-30		30	%
		Between Y and Z <sup>(18)</sup>	-30		30	%
Magnetic Angle Phase error	$ORTH_{XY}$ $ORTH_{XZ}$ $ORTH_{YZ}$	$T_A = 25^\circ C$ Between X and Y	-0.3		0.3	Deg
		Between X and Z	-10		10	Deg
		Between Y and Z	-10		10	Deg
Thermal Offset Drift #1 on the raw signals X, Y and Z <sup>(19)</sup>		Thermal Offset Drift at the DSP input (excl. DAC and output stage) Temperature suffix K	-60		+60	LSB <sub>15</sub>
		Temperature suffix L	-90		+90	LSB <sub>15</sub>
Thermal Offset Drift #2 (to be considered only for the analog output mode)		Thermal Offset Drift of the DAC and Output Stage Temperature suffix K	-0.3		+0.3	%VDD
		Temperature suffix L	-0.4		+0.4	%VDD
Thermal Drift of Sensitivity Mismatch	$\Delta SMISM_{XY}$	Temperature suffix K	-0.3		+0.3	%
		Temperature suffix L	-0.5		+0.5	%
	$\Delta SMISM_{XZ}$ $\Delta SMISM_{YZ}$	Temperature suffix K	-1		+1	%
		Temperature suffix L	-1.5		+1.5	%
Analog Output Resolution	$R_{DAC}$	12 bits DAC (Theoretical – Noise free)		0.025		%VDD/LSB
		INL	-4		+4	LSB
		DNL	-1	0	1	LSB
Output stage Noise		Clamped Output		0.05		%VDD
MLX90333 Accuracy Specification continues...						

<sup>17</sup> 15 bits corresponds to 14 bits + sign and 14 bits corresponds to 13 bits + sign. After angular calculation, this corresponds to 0.005Deg/LSB<sub>15</sub> in Low Speed Mode and 0.01Deg/LSB<sub>14</sub> in High Speed.

<sup>18</sup> The mismatch between X and Z (Y and Z) can be reduced through the calibration of the 2 parameters  $k_z$  and  $k_l$  as described in the formulas page 12 in order to take into account the IC mismatch and system tolerances (magnetic and mechanical).

<sup>19</sup> To evaluate the error affecting the computed angle i.e. "ATAN" function (See section 6), it is important to take into account the actual value of the factor  $k_z$  as it amplifies the signal  $V_z$  and consequently its drift too.

... MLX90333 Accuracy Specification						
Noise pk-pk <sup>(20)</sup>		Gain = 14, Slow mode, Filter=5 Gain = 14, Fast mode, Filter=0		5 10	10 20	LSB <sub>15</sub> LSB <sub>15</sub>
Ratiometry Error			-0.1	0	0.1	%VDD
PWM Output Resolution	R <sub>PWM</sub>	12 bits (Theoretical – Jitter free)		0.025		%DC/LSB
PWM Jitter	J <sub>PWM</sub>	Gain = 11, F <sub>PWM</sub> = 250 Hz – 800Hz			5	LSB <sub>12</sub>
Serial Output Resolution	R <sub>SPI</sub>	Theoretical – Jitter free		16		bits

## 11. MLX90333 Magnetic Specification

DC Operating Parameters at VDD = 5V (unless otherwise specified) and for T<sub>A</sub> as specified by the Temperature suffix (K or L).

Parameter	Symbol	Test Conditions	Min	Typ	Max	Units
Magnetic Flux Density	B <sub>X</sub> , B <sub>Y</sub> <sup>(21)</sup>		20	50	70 <sup>(22)</sup>	mT
Magnetic Flux Density	B <sub>Z</sub> <sup>(21)</sup>		24	75	140	mT
Magnet Temperature Coefficient	TC <sub>m</sub>		-2400		0	ppm/°C
IMC Gain <sup>(23)</sup>	Gain <sub>IMC</sub>		1.2	1.4	1.8	

## 12. MLX90333 CPU & Memory Specification

The DSP is based on a 16 bit RISC  $\mu$ Controller. This CPU provides 5 Mips while running at 20 MHz.

Parameter	Symbol	Test Conditions	Min	Typ	Max	Units
ROM				10		kB
RAM				256		B
EEPROM				128		B

<sup>20</sup> The application diagram used is described in the recommended wiring. For detailed information, refer to section Filter in application mode (Section 14.6).

<sup>21</sup> The condition must be fulfilled for at least one field B<sub>X</sub>, B<sub>Y</sub> or B<sub>Z</sub>.

<sup>22</sup> Above 70 mT, the IMC starts saturating yielding to an increase of the linearity error.

<sup>23</sup> This is the magnetic gain linked to the Integrated Magneto Concentrator structure. It applies to B<sub>X</sub> and B<sub>Y</sub> and not to B<sub>Z</sub>. This is the overall variation. Within one lot, the part to part variation is typically  $\pm 10\%$  versus the average value of the IMC gain of that lot.

### 13. MLX90333 End-User Programmable Items

Parameter	Comments	Default Values			# bit
		BCH STD/IP1	BCH SPI	BCT STD/IP1	
MAINMODE	Select Outputs Configuration	0	0	0	2
Outputs Mode	Define the output stages mode	2	N/A	2	3
PWMPOL1	PWM Polarity (Out 1)	0	N/A	0	1
PWMPOL2	PWM Polarity (Out 2)	0	N/A	0	1
PWM_Freq	PWM Frequency	1000h	N/A	1000h	16
3-Points	4 segments transfer curve for single angle output	0	0	0	1
ALPHA_POL	Revert the Sign of Alpha	0	0	0	1
ALPHA_MOD180	Modulo Operation (180deg) on Alpha	1	1	1	1
ALPHA_DP	Alpha Discontinuity Point	0	0	0	8
ALPHA_DEADZONE	Alpha Dead Zone	0	0	0	6
ALPHA_S0	Initial Slope	4000h	4000h	4000h	16
ALPHA_X	Alpha X Coordinate	4000h	4000h	4000h	16
ALPHA_Y	Alpha Y Coordinate	8000h	8000h	8000h	16
ALPHA_S1	Alpha S Coordinate	4000h	4000h	4000h	16
BETA_POL	Revert the Sign of Beta	0	0	0	1
BETA_MOD180	Modulo Operation (180deg) on Beta	1	1	1	1
BETA_DP	Beta Discontinuity Point	0	0	0	6
BETA_DEADZONE	Beta Dead Zone	0	0	0	8
BETA_S0	Beta Dead Zone	4000h	4000h	4000h	16
BETA_X	Beta X Coordinate	4000h	4000h	4000h	16
BETA_Y	Beta Y Coordinate	8000h	8000h	8000h	16
BETA_S1	Beta S Coordinate	4000h	4000h	4000h	16
CLAMP_LOW	Clamping Low	0%	0%	0%	16
CLAMP_HIGH	Clamping High	100%	100%	100%	16
2D		0	0	0	1
XYZ	SPI Only	0	0	0	1
KZ		B3h	B3h		8
KT <sup>(24)</sup>		80h	80h	N/A	8
FIELDTHRES_LOW		0h	0h	0h	8
FIELDTHRES_HIGH		0h	0h	0h	8
DERIVGAIN		40h	40h	40h	8
FILTER		3	0	3	8
FILTER A1	Filter coefficient A1 for FILTER=6	6600h	6600h	6600h	16
FILTER A2	Filter coefficient A2 for FILTER=6	2A00h	2A00h	2A00h	16
FILTERFIRST		0	0	0	1
FHYST		0	0	0	8
MELEXISID1		MLX	MLX	MLX	16
MELEXISID2		MLX	MLX	MLX	16
MELEXISID3		MLX	MLX	MLX	16
CUSTOMERID1		1	1	1	16
CUSTOMERID2		17d <sup>(25)</sup>	37d	38d	16
CUSTOMERID3		MLX	MLX	MLX	16
HIGHSPEED		0	0	0	1
GAINMIN		0	0	0	8
GAINMAX		41d	41d	41d	8

*End-User Programmable Items continues...*

<sup>24</sup> Only applicable for 90333BCH

<sup>25</sup> CUSTOMERID2 = 29d for MLX90333SDC-BCH-STANDARD

<i>... End-User Programmable Items</i>					
EEHAMHOLE		3131h	0h	3131h	16
RESONFAULT	Diagn mode	1h	N/Ah	0h	2
MLXLOCK		0h	0h	0h	1
LOCK		0h	1h	0h	1
<i>Extra end-User Programmable Items 90333BCT</i>					
AGCRADIUSTARGET <sup>(26)</sup>	Define Gain target 64% / 90% ADC	N/A	N/A	0	1
SWTHRES	Angle Trigger level for switch on out2	N/A	N/A	FFFFh	16
SWLOW	Switch Low level output on out2	N/A	N/A	40h	8
SWHIGH	Switch high level output on out2	N/A	N/A	FFh	8
SWHYST	Switch hysteresis	N/A	N/A	0	8
CodePWMLATCH	Enable synchronized % DC update	N/A	N/A	1	1
OUT1DIAG	Active Diagnostic Output 1 behavior	N/A	N/A	0	1
OUT2DIAG	Active Diagnostic Output 2 behavior	N/A	N/A	0	1
CodeKTALPHA	"Joystick" ALPHA angle correction parameter	N/A	N/A	80h	8
CodeKTBETA	"Joystick" BETA angle correction parameter	N/A	N/A	80h	8
CodeORTHZXALPHA	Front-end "Joystick" angle correction parameter	N/A	N/A	0	8
CodeORTHZYALPHA	Front-end "Joystick" angle correction parameter	N/A	N/A	0	8
CodeORTHZXBETA	Front-end "Joystick" angle correction parameter	N/A	N/A	0	8
CodeORTHZXBETA	Front-end "Joystick" angle correction parameter	N/A	N/A	0	8
CodeENHORTH	Enable enhanced Front-end "Joystick" angle correction	N/A	N/A	0	1

<sup>26</sup> Option to use same ADC target as 90333BCH. Default value equals lowered % ADC target

## 14. Description of End-User Programmable Items

### 14.1. Output Configuration

The parameter MAINMODE defines the output stages configuration

MAINMODE	OUT1	OUT2
0	ALPHA	BETA
1	BETA	ALPHA
2	ALPHA	ALPHA DERIVATE / SWITCH <sup>(27)</sup>
3	BETA	BETA DERIVATE / SWITCH <sup>(27)</sup>

### 14.2. Output Mode

The MLX90333 outputs type is defined by the Output Mode parameter.

Parameter	Value	Description
Analog Output Mode	2	Analog Rail-to-Rail
PWM Output Mode	5	Low Side (NMOS)
	7	Push-Pull
Serial	N/A	Low Side (NMOS)

#### 14.2.1. Analog Output Mode

The Analog Output Mode is a rail-to-rail and ratiometric output with a push-pull output stage configuration allows the use of a pull-up or pull-down resistor.

#### 14.2.2. PWM Output Mode

If one of the PWM Output modes is selected, the output signal is a digital signal with Pulse Width Modulation (PWM).

In mode 5, the output stage is an open drain NMOS transistor (low side), to be used with a pull-up resistor to V<sub>DD</sub>.

In mode 7, the output stage is a push-pull stage for which Melexis recommends the use of a pull-up resistor to V<sub>DD</sub>.

The PWM polarity of the Out 1 (Out 2) is selected by the PWMPOL1 (PWMPOL2) parameter:

- PWMPOL1 (PWMPOL2) = 0 for a low level at 100%
- PWMPOL1 (PWMPOL2) = 1 for a high level at 100%

The PWM frequency is selected by the PWM\_Freq parameter.

PWM Frequency Code				
Oscillator Mode	Pulse-Width Modulation Frequency (Hz)			
	100	200	500	1000
Low Speed	35000	17500	7000	3500
High Speed	-	50000	20000	10000

<sup>27</sup> Derivate = BCH , Switch = BCT

For instance, in Low Speed Mode, set PWM\_Freq = 7000 (decimal) to set the PWM frequency at 500Hz.

### 14.2.3. Serial Protocol Output Mode

The MLX90333 features a digital Serial Protocol mode. The MLX90333 is considered as a Slave node. The frame layer type is defined by the parameter XYZ as described in the next table.

Parameter	Value	Description
XYZ	0	Regular SPI Frame Alpha, Beta
	1	X,Y, Z Frame

See the dedicated Serial Protocol section for a full description (Section 16).

### 14.2.4. Switch Out

Parameter	Value	Unit
SWTHRES	0...100	%
SWHYST	0 ... 0.39	%
SWLOW	0...100	%
SWHIGH	0...100	%

The output level on out2 is changed from SWLOW to SWHIGH when the output value is greater than the value stored in the SWTHRES parameter.

The SWHYST defines the hysteresis amplitude around the Switch point. The switch is actually activated if the digital output value is greater than SWTHRES+SWHYST. It is deactivated if the digital output value is less than SWTHRES-SWHYST.

If the Switch feature is not used in the application, the output pin needs to be connected to the ground and disabled in EEPROM.

## 14.3. Output Transfer Characteristic

Parameter	Value	Description
3-Points	0	Regular Alpha, Beta Output (2 times 2 segments)
	1	Alpha (or Beta) Single Output (1 time 4 segments)

The 3-Points parameters allow the user to use the 3-points mapping (4 segments). This mode can only be used for Mainmode equals 2 and 3.

- 3-Points = 0, the parameters list is described as bellow (Angle Alpha and Beta):

Parameter	Value	Unit
ALPHA_POL	0	
BETA_POL	1	
ALPHA_MOD180	0	
BETA_MOD180	1	

ALPHA_DP BETA_DP	0 ... 359.9999	deg
ALPHA_X BETA_X	0 ... 359.9999	deg
ALPHA_Y BETA_Y	0 ... 100	%
ALPHA_S0 ALPHA_S1 BETA_S0 BETA_S1	0 ... 17	%/deg
CLAMP_LOW	0 ... 100	%
CLAMP_HIGH	0 ... 100	%
ALPHA_DEADZONE BETA_DEADZONE	0 ... 359.9999	deg

- 3-Points = 1, the parameters list is described as bellow (Alpha or Beta):

Parameter	Value	Unit
ALPHA_POL	0 → CCW 1 → CW	
DP	0 ... 359.9999	deg
LNR_A_X LNR_B_X LNR_C_X	0 ... 359.9999	deg
LNR_A_Y LNR_B_Y LNR_C_Y	0 ... 100	%
LNR_S0 LNR_A_S LNR_B_S	0 ... 17	%/deg
LNR_C_S	-17... 0 ... 17	%/deg
CLAMP_LOW	0 ... 100	%
CLAMP_HIGH	0 ... 100	%
DEADZONE	0 ... 359.9999	deg

### 14.3.1. The Polarity and Modulo Parameters

The angle Alpha is defined as the arctangent of Z/X and Beta as the arctangent of Z/Y. It is possible to invert the polarity of these angles via the parameters ALPHA\_POL and BETA\_POL set to "1".

The MLX90333 can also be insensitive to the field polarity by setting the ALPHA\_MOD180/BETA\_MOD180 to "1".

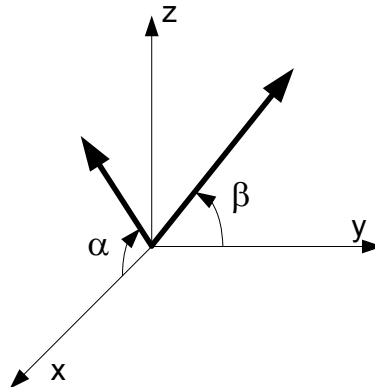

**14.3.2. Alpha/Beta Discontinuity Point (or Zero Degree Point)**

The Discontinuity Point defines the zero point of the circle (Alpha or Beta). The discontinuity point places the origin at any location of the trigonometric circle (see Figure 13). For a Joystick Application, Melexis recommends to set the DP to zero.

**14.3.3. LNR Parameters**

The LNR parameters, together with the clamping values, fully define the relation (the transfer function) between the digital angles (Alpha and Beta) and the output signals. The shape of the MLX90333 transfer function from the digital angle values to the output voltages is described by the drawing below (See Figure 11). Four segments can be programmed but the clamping levels are necessarily flat (3-Points = 0).

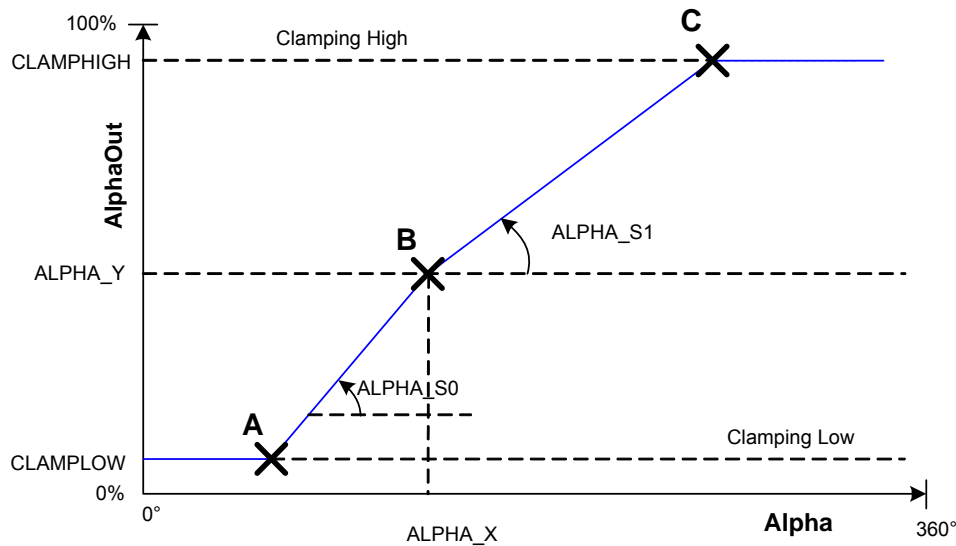

Figure 11 - Digital Angle (Alpha) Transfer Characteristic (Idem ditto for Beta)

In the case of one single angle output (3-Points = 1), the shape of the MLX90333 transfer function from the digital angle values to the output voltage is described by the drawing below (See Figure 12). Six segments can be programmed but the clamping levels are necessarily flat.



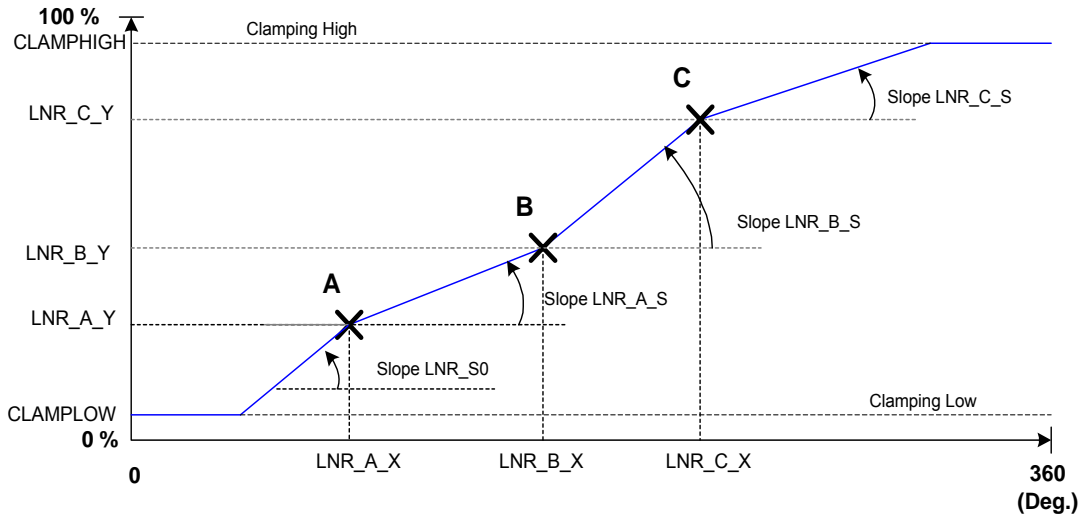

Figure 12 – Digital Angle (Alpha) Transfer Characteristic for Single Angle Output

#### 14.3.4. CLAMPING Parameters

The clamping levels are two independent values to limit the output voltage range. The CLAMP\_LOW parameter adjusts the minimum output voltage level. The CLAMP\_HIGH parameter sets the maximum output voltage level. Both parameters have 16 bits of adjustment. In analog mode, the resolution will be limited by the D/A converter (12 bits) to 0.024%V<sub>DD</sub>. In PWM mode, the resolution will be 0.024%DC. In SPI mode, the resolution is 14bits or 0.022deg over 360deg.

#### 14.3.5. DEADZONE Parameter

The dead zone is defined as the angle window between 0 and 359.9999 (See Figure 13). When the digital angle (Alpha or Beta) lies in this zone, the IC is in fault mode (RESONFAULT must be set to “1” – See 14.8.2).

In case of ALPHA\_MOD180 (or BETA\_MOD180) is not set, the angle between 180° and 360° will generate a “deadzone” fault, unless DEADZONE=0.

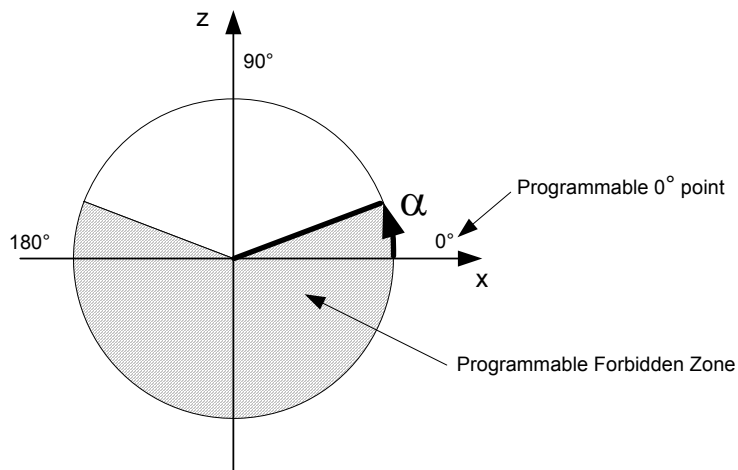

Figure 13 – Discontinuity Point and Dead Zone (Alpha – Idem ditto for Beta)

## 14.4. Identification

Parameter	Value	Unit
MELEXSID1	0 ... 65535	
MELEXSID2	0 ... 65535	
MELEXSID3	0 ... 65535	
CUSTOMERID1	0 ... 65535	
CUSTOMERID2	0 ... 65535	
CUSTOMERID3	0 ... 65535	

Identification number: 48 bits freely useable by Customer for traceability purpose.

## 14.5. Sensor Front-End

Parameter	Value	Unit
HIGHSPEED	0 = Slow mode 1 = Fast mode	
GAINMIN	0 ... 41	
GAINMAX	0 ... 41	
FIELDTHRES_LOW	0 ... 100	%
FIELDTHRES_HIGH	0 ... 100	%

### 14.5.1. HIGHSPEED Parameter

The HIGHSPEED parameter defines the main frequency for the DSP.

- HIGHSPEED = 0 selects the Slow mode with a 7 MHz master clock.
- HIGHSPEED = 1 selects the Fast mode with a 20 MHz master clock.

For better noise performance, the Slow Mode must be enabled.

### 14.5.2. GAINMIN and GAINMAX Parameters

The MLX90333 features an automatic gain control (AGC) of the analog chain. The AGC loop is based on  $\text{Max}(|V_x|, |V_y|, |V_z|) = |\text{Amplitude}| = \text{Radius}$

and it targets an amplitude of 90% of the ADC input span.

In MLX90333BCT, this default target is changed to 64% but can be set to 90% by enabling the parameter AGCRADIUSTARGET.

The current gain can be read out with the programming unit PTC-04 and gives a rough indication of the applied magnetic flux density (Amplitude).

GAINMIN & GAINMAX define the boundaries within the gain setting is allowed to vary. Outside this range, the outputs are set in diagnostic low.

### 14.5.3. FIELDTHRES\_LOW and FIELDTHRES\_HIGH Parameters

The strength of the applied field is constantly calculated in a background process. The value of this field can be read out with the PTC-04 and gives a rough indication of the applied magnetic flux density (Amplitude).

FIELDTHRES\_LOW & FIELDTHRES\_HIGH define the boundaries within the actual field strength (Radius) is allowed to vary. Outside this range, the outputs are set in diagnostic low.

## 14.6. FILTER

Parameter	Value	Unit
FHYST	0 ... 11 ; step 0.04	deg
FILTER	0... 6	
FILTERFIRST	0 1	

The MLX90333 includes 3 types of filters:

- Hysteresis Filter: programmable by the FHYST parameter
- Low Pass FIR Filters controlled with the Filter parameter
- Low Pass IIR Filter controlled with the Filter parameter and the coefficients FILTER A1 and FILTER A2

Note: if the parameter FILTERFIRST is set to “1”, the filtering is active on the digital angle. If set to “0”, the filtering is active on the output transfer function.

### 14.6.1. Hysteresis Filter

The FHYST parameter is a hysteresis filter. The output value of the IC is not updated when the digital step is smaller than the programmed FHYST parameter value. The output value is modified when the increment is bigger than the hysteresis. The hysteresis filter reduces therefore the resolution to a level compatible with the internal noise of the IC. The hysteresis must be programmed to a value close to the noise level.

### 14.6.2. FIR Filters

The MLX90333 features 6 FIR filter modes controlled with Filter = 0...5. The transfer function is described below:

$$y_n = \frac{1}{\sum_{i=0}^j a_i} \sum_{i=0}^j a_i x_{n-i}$$

The characteristics of the filters no 0 to 5 is given in the Table 1.

Filter No (j)	0	1	2	3	4	5
Type	Disable	Finite Impulse Response				
Coefficients a <sub>0</sub> ... a <sub>5</sub>	N/A	110000	121000	133100	111100	122210
Title	No Filter	Extra Light		Light		
90% Response Time (C <sub>T</sub> )	1	2	3	4	4	5
99% Response Time (C <sub>T</sub> )	1	2	3	4	4	5
Efficiency RMS (dB)	0	2.9	4.0	4.7	5.6	6.2
Efficiency P2P (dB)	0	2.9	3.6	5.0	6.1	7.0

Table 1 - FIR Filters Selection Table

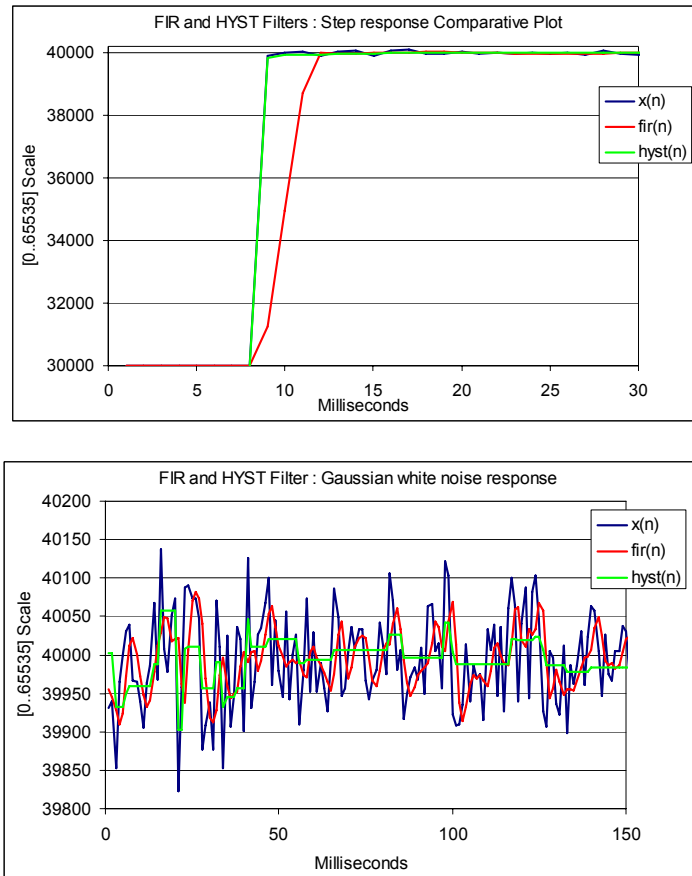

Figure 14 - Step Response and Noise Response for FIR (No 3) and FHYST=10

**14.6.3. IIR Filters**

The IIR Filter is enabled with Filter = 6. The diagram of the IIR Filter implemented in the MLX90333 is given in Figure 15. Only the parameter A1 and A2 are configurable (See Table 2).

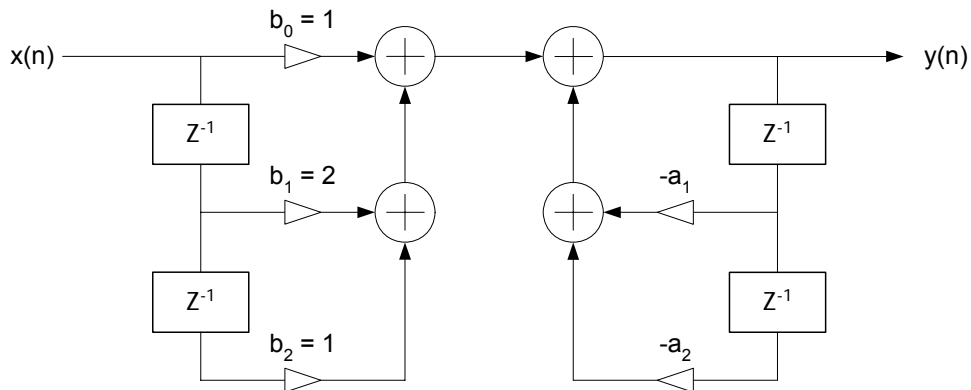

Figure 15 - IIR Diagram

Filter No	6					
Type	2 <sup>nd</sup> Order Infinite Impulse Response (IIR)					
Title	Medium & Strong					
90% Response Time (C <sub>T</sub> )	11	16	26	40	52	100
Efficiency RMS (dB)	9.9	11.4	13.6	15.3	16.2	>20
Efficiency P2P (dB)	12.9	14.6	17.1	18.8	20	>20
Coefficient A1	26112	28160	29120	30208	31296	31784
Coefficient A2	10752	12288	12992	13952	14976	15412

Table 2 - IIR Filter Selection Table

The Figure 16 shows the response of the filter to a Gaussian noise with default coefficient A1 and A2.

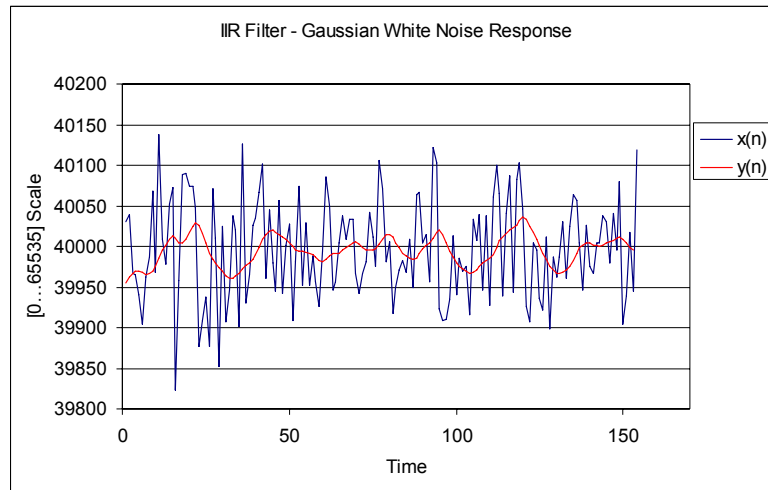

Figure 16 - Noise Response for the IIR Filter

#### 14.7. Programmable enhanced “joystick’ angle correction<sup>28</sup>

Parameter	Value	Unit
KTALPHA KTBETA	[0..200] / 128	LSB
ORTHZXALPHA ORTHZYALPHA ORTHZXBETA ORTHZXBETA	[-128...127] / 256	LSB
ENHORTH	Disable = 0 Enable = 1	

<sup>28</sup> Only applicable for 90333BCT

**14.7.1. Enhanced “Joystick” Angle Formula**

$$\alpha = ATAN \left( \frac{\sqrt{(k_z V_z)^2 + (k_t (V_y - ORTH_{zy} * V_z))^2}}{V_x - ORTH_{zx} * V_z} \right)$$

$$\beta = ATAN \left( \frac{\sqrt{(k_z V_z)^2 + (k_t (V_x - ORTH_{zx} * V_z))^2}}{V_y - ORTH_{zy} * V_z} \right)$$

The enhanced “joystick” angle function is enabled by parameter ENORTH. Parameters are automatically calculated when using the 90333BCT/ 9 points solver to optimize the shape of Betaout vs Alphaout in accordance to the mechanical boundaries of the Joystick

**14.8. Programmable Diagnostic Settings**

Parameter	Value
OUT1DIAG	DIAGLOW = 0 DIAGHIGH = 1
OUT2DIAG	DIAGLOW = 0 DIAGHIGH = 1
RESONFAULT	Disable = 0 Enable = 1
EEHAMHOLE	Enable = 0 Disable = 3131h

**14.8.1. OUTxDIAG Parameter**

This OUT1DIAG, OUT2DIAG parameters define the behavior of the output in case of a diagnostic situation.

**14.8.2. RESONFAULT Parameter**

This RESONFAULT parameter enables the soft reset when a fault is detected by the CPU when the parameter is set to 1. It is recommended to set it to “1” to activate the self diagnostic modes (See section 15).

Note that in the User Interface (MLX90333UI), the RESONFAULT is a cluster of the following two bits, i.e. the 2 bits are both disabled or both enabled:

- DRESONFAULT: disable the reset in case of a fault.
- DOUTINFALT: disable output in diagnostic low in case of fault.

It is recommended to set both EEPROM parameters to “0” to activate the self diagnostic modes

**14.8.3. EEHAMHOLE Parameter**

The EEHAMHOLE parameter disables the CRC check and memory recovery (Hamming code) check when a fault is detected by the CRC when it is equal to 3131h. Melexis strongly recommends to set the parameter to 0 (enable memory recovery). The parameter is set automatically to 0 by the solver function “MemLock”.

## 14.9. Lock

Parameter	Value
MLXLOCK	0 1
LOCK	0 1

### 14.9.1. MLXLOCK Parameter

MLXLOCK locks all the parameters set by Melexis.

### 14.9.2. LOCK Parameter

LOCK locks all the parameters set by the user. Once the lock is enabled, it is not possible to change the EEPROM values anymore.

Note that the lock bit should be set by the solver function "MemLock".

## 15. MLX90333 Self Diagnostic

The MLX90333 provides numerous self-diagnostic features. Those features increase the robustness of the IC functionality as it will prevent the IC to provide erroneous output signal in case of internal or external failure modes ("fail-safe").

	Action	Effect on Outputs	Remark
ROM CRC Error at start up (64 words including Intelligent Watch Dog - IWD)	CPU Reset <sup>(29)</sup>	Diagnostic low <sup>(30)</sup>	All the outputs are already in Diagnostic low - (start-up)
ROM CRC Error (Operation - Background task)	Enter Endless Loop: - Progress (watchdog Acknowledge) - Set Outputs in Diagnostic low	Immediate Diagnostic low	
RAM Test Fail (Start up)	CPU Reset	Diagnostic low	All the outputs are already in Diagnostic low (start-up)
Calibration Data CRC Error (Start-Up)	Hamming Code Recovery		Start-Up Time is increased by 3 ms if successful recovery
Hamming Code Recovery Error (Start-Up)	CPU Reset	Immediate Diagnostic low	See 14.8.3
Calibration Data CRC Error (Operation - Background)	CPU Reset	Immediate Diagnostic low	
Dead Zone Alpha Dead Zone Beta	Set Outputs in Diagnostic low. Normal Operation until the "dead zone" is left.	Immediate Diagnostic low	Immediate recovery if the "dead zone" is left
ADC Clipping (ADC Output is 0000h or 7FFFh)	Set Outputs in Diagnostic low Normal mode and CPU Reset If recovery	Immediate Diagnostic low	
Radius Overflow ( > 100% ) or Radius Underflow ( < 50 % )	Set Outputs in Diagnostic low Normal mode and CPU Reset If recovery	Immediate Diagnostic low	(50 % - 100 %) No magnet / field too high See also 14.5.2
Field Clipping (Radius < FIELDTHRES_LOW or Radius > FIELDTHRES_HIGH)	Set Outputs in Diagnostic low Normal mode, and No CPU Reset If recovery	Immediate Diagnostic low	
Rough Offset Clipping (RO is < 0d or > 127d)	Set Outputs in Diagnostic low Normal mode, and CPU Reset If recovery	Immediate Diagnostic low	
Gain Clipping (Gain < GAINMIN or GAIN > GAINMAX)	Set Outputs in Diagnostic low Normal mode, and CPU Reset If recovery	Immediate Diagnostic low	See also 14.5.2
DAC Monitor (Digital to Analog converter)	Set Outputs in Diagnostic low. Normal Mode with immediate recovery without CPU Reset	Immediate Diagnostic low	
<i>MLX90333 Fault Mode continues...</i>			

<sup>29</sup> CPU reset means

1. Core Reset (same as Power-On-Reset). It induces a typical start up time.
2. Periphery Reset (same as Power-On-Reset)
3. Fault Flag/Status Lost
4. The reset can be disabled by clearing the RESONFAULT bit (See 14.8.2)

<sup>30</sup> Refer to section 7 for the Diagnostic Output Level specifications



...MLX90333 Fault Mode			
Fault Mode	Action	Effect on Outputs	Remark
ADC Monitor (Analog to Digital Converter)	Set Outputs in Diagnostic low. Normal Mode with immediate recovery without CPU Reset	Immediate Diagnostic low	ADC Inputs are Shorted
Undervoltage Mode	At Start-Up, wait Until $V_{DD} > 3V$ .  During operation, CPU Reset after 3 ms debouncing	- $V_{DD} < \text{POR level} \Rightarrow$ Outputs high impedance  - $\text{POR level} < V_{DD} < 3 V \Rightarrow$ Outputs in Diagnostic low.	
Firmware Flow Error	CPU Reset	Immediate Diagnostic low	Intelligent Watchdog (Observer)
Read/Write Access out of physical memory	CPU Reset	Immediate Diagnostic low	100% Hardware detection
Write Access to protected area (IO and RAM Words)	CPU Reset	Immediate Diagnostic low	100% Hardware detection
Unauthorized entry in "SYSTEM" Mode	CPU Reset	Immediate Diagnostic low	100% Hardware detection
$V_{DD} > 7 V$	Set Output High Impedance (Analog)	Pull down resistive load $\Rightarrow$ Diag. Low Pull up resistive load $\Rightarrow$ Diag. High <sup>(30)</sup>	100% Hardware detection
$V_{DD} > 9.4 V$	IC is switched off (internal supply) CPU Reset on recovery	Pull down resistive load $\Rightarrow$ Diag. Low Pull up resistive load $\Rightarrow$ Diag. High	No valid diagnostic for $V_{PULLUP} = V_{DD}$ .  Pull up load ( $\leq 10k\Omega$ ) to $V_{PULLUP} > 8 V$ to meet Diag Hi spec $> 96\% V_{DD}$ .
Broken Vss	CPU Reset on recovery	Pull down resistive load $\Rightarrow$ Diag. Low Pull up resistive load $\Rightarrow$ Diag. High	100% Hardware detection. Pull down load $\leq 10 k\Omega$ to meet Diag Low spec: - $< 4\% V_{DD}$ (temperature suffix K) - contact Melexis for temperature suffix L
Broken VDD	CPU Reset on recovery	Pull down resistive load $\Rightarrow$ Diag. Low Pull up resistive load $\Rightarrow$ Diag. High	No valid diagnostic for $V_{PULLUP} = V_{DD}$ .  Pull up load ( $\leq 10k\Omega$ ) to $V_{PULLUP} > 8 V$ to meet Diag Hi spec $> 96\% V_{DD}$ .

## **16. Serial Protocol**

### **16.1. Introduction**

The MLX90333 features a digital Serial Protocol mode. The MLX90333 is considered as a Slave node. The serial protocol of the MLX90333 is a three wires protocol (/SS, SCLK, MOSI-MISO):

- /SS pin is a 5 V tolerant digital input
- SCLK pin is a 5 V tolerant digital input
- MOSI-MISO pin is a 5 V tolerant open drain digital input/output

The basic knowledge of the standard SPI specification is required for the good understanding of the present section.

### **16.2. SERIAL PROTOCOL Mode**

- CPHA = 1 → even clock changes are used to sample the data
- CPOL = 0 → active-Hi clock

The positive going edge shifts a bit to the Slave's output stage and the negative going edge samples the bit at the Master's input stage.

### **16.3. MOSI (Master Out Slave In)**

The Master sends a command to the Slave to get the angle information.

### **16.4. MISO (Master In Slave Out)**

The MISO of the slave is an open-collector stage. Due to the capacitive load (TBD) a >1 k $\Omega$  pull-up is used for the recessive high level (in fast mode). Note that MOSI and MISO use the same physical pin of the MLX90333.

### **16.5. /SS (Slave Select)**

The /SS pin enables a frame transfer (if CPHA = 1). It allows a re-synchronization between Slave and Master in case of communication error.

### **16.6. Master Start-Up**

/SS, SCLK, MISO can be undefined during the Master start-up as long as the Slave is re-synchronized before the first frame transfer.

### **16.7. Slave Start-Up**

The slave start-up (after power-up or an internal failure) takes 16 ms. Within this time /SS and SCLK is ignored by the Slave. The first frame can therefore be sent after 16 ms. MISO is Hi-Z (i.e. Hi-Impedance) until the Slave is selected by its /SS input. MLX90333 will cope with any signal from the Master while starting up.

### 16.8. Timing

To synchronize communication, the Master deactivates /SS high for at least  $t_5$  (1.5 ms). In this case, the Slave will be ready to receive a new frame. The Master can re-synchronize at any time, even in the middle of a byte transfer.

Note: Any time shorter than  $t_5$  leads to an undefined frame state, because the Slave may or may not have seen /SS inactive.

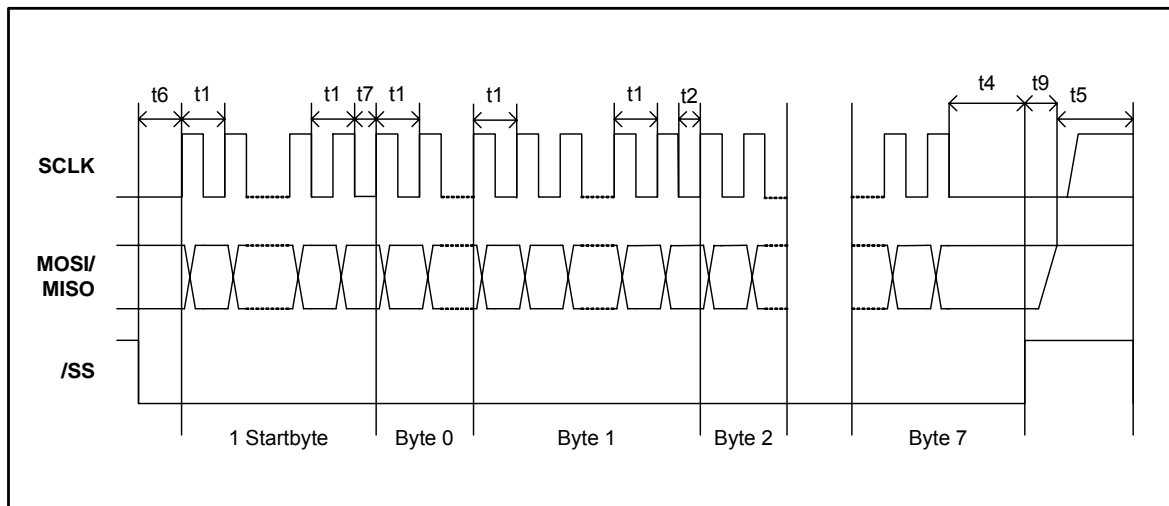

Timings	Min <sup>(31)</sup>	Max	Remarks
t1	2.3 $\mu$ s / 6.9 $\mu$ s	-	No capacitive load on MISO. t1 is the minimum clock period for any bits within a byte.
t2	12.5 $\mu$ s / 37.5 $\mu$ s	-	t2 the minimum time between any other byte
t4	2.3 $\mu$ s / 6.9 $\mu$ s	-	Time between last clock and /SS=high=chip de-selection
t5	300 $\mu$ s / 1500 $\mu$ s	-	Minimum /SS = Hi time where it's guaranteed that a frame re-synchronizations will be started.
t5	0 $\mu$ s	-	Maximum /SS = Hi time where it's guaranteed that NO frame re-synchronizations will be started.
t6	2.3 $\mu$ s / 6.9 $\mu$ s	-	The time t6 defines the minimum time between /SS = Lo and the first clock edge
t7	15 $\mu$ s / 45 $\mu$ s	-	t7 is the minimum time between the StartByte and the Byte0
t9	-	<1 $\mu$ s	Maximum time between /SS = Hi and MISO Bus High-Impedance
T <sub>StartUp</sub>	-	< 10 ms / 16 ms	Minimum time between reset-inactive and any master signal change

<sup>31</sup> Timings shown for oscillator base frequency of 20MHz (Fast Mode) / 7 MHz (Slow Mode)

## 16.9. Slave Reset

On internal soft failures the Slave resets after 1 second or after an (error) frame is sent. On internal hard failures the Slave resets itself. In that case, the Serial Protocol will not come up. The serial protocol link is enabled only after the completion of the first synchronization (the Master deactivates /SS for at least t5).

## 16.10. Frame Layer

### 16.10.1. Frame Type Selection

See the programmable parameter XYZ in section 14.2.3 to select between the Alpha, Beta Frame and the X, Y, Z Frame.

### 16.10.2. Data Frame Structure

The Figure 17 gives the timing diagram for the SPI Frame. The latch point for the angle measurement is at the last clock before the first data frame byte.

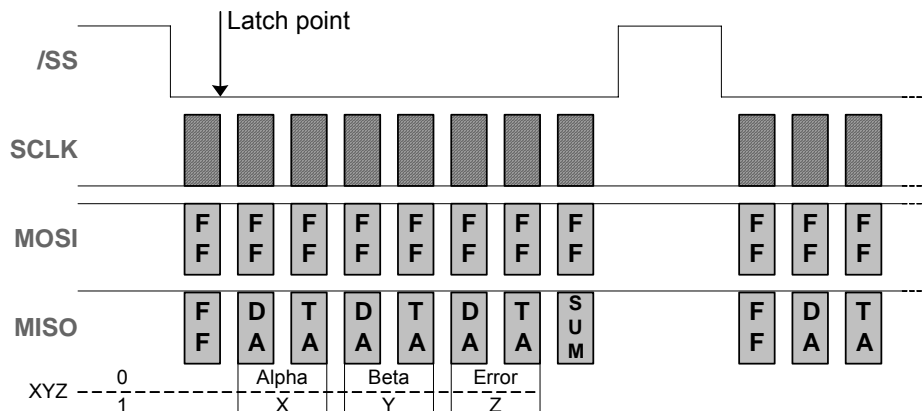

Figure 17 - Timing Diagram for the SPI Frame

A data frame consists of:

Data Frame	XYZ = 0	XYZ = 1
1 start byte	FFh	
2 data bytes (LSByte first)	Alpha	X
2 data bytes (LSByte first)	Beta	Y
2 data bytes (LSByte first)	Error Code	Z
1 SUM byte	8 LSB of the sum of the transmitted bytes	

### 16.10.3. Timing

There are no timing limits for frames: a frame transmission could be initiated at any time. There is no inter-frame time defined.

### 16.10.4. Data Structure

The DATA could be a valid angle/field component or an error condition.

DATA: Angle/ Field Component A[15:0] with (Span)/2<sup>16</sup>

Less Significant Byte								Most Significant Byte							
msb							lsb	msb							lsb
A7	A6	A5	A4	A3	A2	A1	A0	A15	A14	A13	A12	A11	A10	A9	A8

DATA: Error

Less Significant Byte								Most Significant Byte							
msb							lsb	msb							lsb
E7	E6	E5	E4	E3	E2	E1	E0	E15	E14	E13	E12	E11	E10	E9	E8

BIT	NAME	
E0	-	
E1	-	
E2	F_ADCMONITOR	ADC Failure
E3	F_ADCSATURA	ADC Saturation (Electrical failure or field too strong)
E4	F_GAINTOOLOW	The gain code is strictly less than EE_GAINMIN
E5	F_GAINTOOHIGH	The gain code is strictly greater than EE_GAINMAX
E6	F_NORMTOOLOW	Goes high when the fast norm (the max of absolute x,y,z) is below 30%
E7	F_FIELDTOOLOW	The norm (Square root) is strictly less than EE_FIELDLOW
E8	F_FIELDTOOHIGH	The norm (Square root) is strictly greater than EE_FIELDHIGH
E9	F_ROCLAMP	Analog Chain Rough Offset Compensation: Clipping
E10	-	
E11	F_DEADZONEALPHA	The angle ALPHA lies in the deadzone
E12	-	
E13	-	
E14	-	
E15	F_DEADZONEBETA	The angle BETA lies in the deadzone

### 16.10.5. Angle Calculation

All communication timing is independent (asynchronous) of the angle data processing. The angle is calculated continuously by the Slave:

- Slow Mode: every 1.5 ms at most.
- Fast Mode: every 350 μs at most.

The last angle calculated is hold to be read by the Master at any time. Only valid angles are transferred by the Slave, because any internal failure of the Slave will lead to a soft reset.

### 16.10.6. Error Handling

In case of any errors listed in section 16.10.4, the Serial protocol will be initialized and the error condition can be read by the master.

In case of any other errors (ROM CRC error, EEPROM CRC error, RAM check error, intelligent watchdog error...) the Slave's serial protocol is not initialized. The MOSI/MISO pin will stay Hi-impedant (no error frames are sent).

## 17. Recommended Application Diagrams

### 17.1. Analog Output Wiring with the MLX90333 in SOIC Package

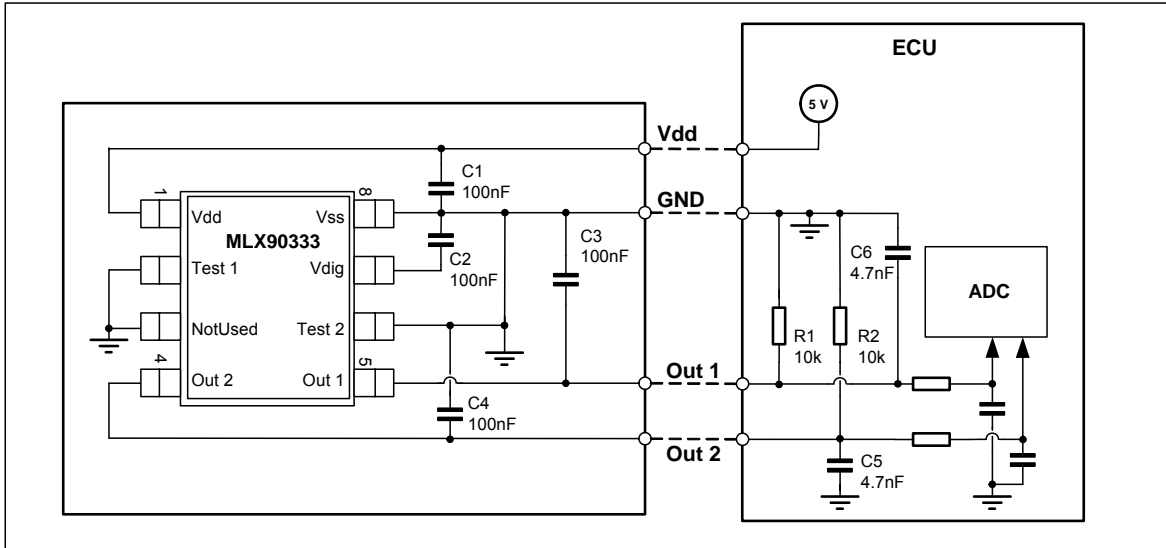

Figure 18 – Recommended wiring for the MLX90333 in SOIC8 package

### 17.2. PWM Low Side Output Wiring

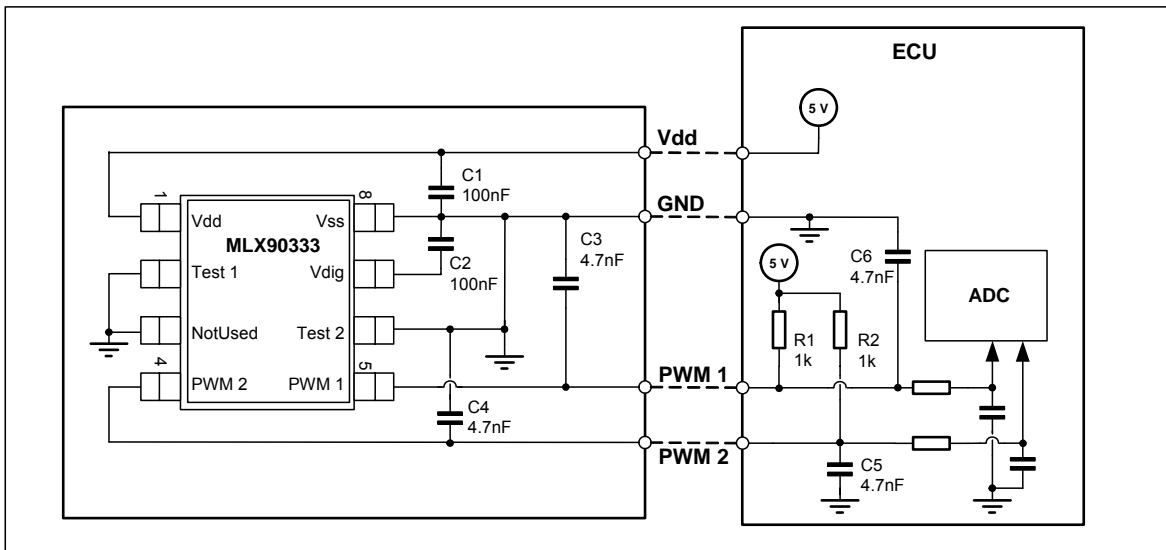

Figure 19 – Recommended wiring for a PWM Low Side Output configuration



Application Type	$\mu$ Ctrl Supply (V)	Pull-up Supply (V)	90316 Supply (V)	R1 ( $\Omega$ )	R2 ( $\Omega$ )	R3 ( $\Omega$ )	R4 ( $\Omega$ )	R5 ( $\Omega$ )	MOS Type
5V $\mu$ Ctrl w/o O.D. w/o 3.3V	5V	5V	5V	100	1000	20,000	1000	20,000	BS170
5V $\mu$ Ctrl w/o O.D. w/ 3.3V	5V	3.3V	5V	150	1000	N/A	1000	20,000	BS170
3.3V $\mu$ Ctrl w/o O.D. <sup>(32)</sup>	3.3V	3.3V	5V	150	1000	N/A	N/A	N/A	BS170
5V $\mu$ Ctrl w/ O.D. w/o 3.3V <sup>(33)</sup>	5V	5V	5V	100	1000	20,000	1000	20,000	N/A
3.3V $\mu$ Ctrl w/ O.D.	3.3V	3.3V	5V	150	1000	N/A	N/A	N/A	N/A

Table 3 - Resistor Values for Common Specific Applications

<sup>32</sup>  $\mu$ Ctrl w/ O.D. : Micro-controller with open-drain capability (for instance NEC V850ES series)

<sup>33</sup>  $\mu$ Ctrl w/o O.D. : Micro-controller without open-drain capability (like TI TMS320 series or ATMEL AVR )



## **18. Standard information regarding manufacturability of Melexis products with different soldering processes**

Our products are classified and qualified regarding soldering technology, solderability and moisture sensitivity level according to following test methods:

### **Reflow Soldering SMD's (Surface Mount Devices)**

- IPC/JEDEC J-STD-020  
Moisture/Reflow Sensitivity Classification for Nonhermetic Solid State Surface Mount Devices (Classification reflow profiles according to table 5-2)
- EIA/JEDEC JESD22-A113  
Preconditioning of Nonhermetic Surface Mount Devices Prior to Reliability Testing (Reflow profiles according to table 2)

### **Wave Soldering SMD's (Surface Mount Devices) and THD's (Through Hole Devices)**

- EN60749-20  
Resistance of plastic- encapsulated SMD's to combined effect of moisture and soldering heat
- EIA/JEDEC JESD22-B106 and EN60749-15  
Resistance to soldering temperature for through-hole mounted devices

### **Iron Soldering THD's (Through Hole Devices)**

- EN60749-15  
Resistance to soldering temperature for through-hole mounted devices

### **Solderability SMD's (Surface Mount Devices) and THD's (Through Hole Devices)**

- EIA/JEDEC JESD22-B102 and EN60749-21  
Solderability

For all soldering technologies deviating from above mentioned standard conditions (regarding peak temperature, temperature gradient, temperature profile etc) additional classification and qualification tests have to be agreed upon with Melexis.

The application of Wave Soldering for SMD's is allowed only after consulting Melexis regarding assurance of adhesive strength between device and board.

For more information on the lead free topic please see quality page at our website:  
<http://www.melexis.com/quality.aspx>

## **19. ESD Precautions**

Electronic semiconductor products are sensitive to Electro Static Discharge (ESD).  
Always observe Electro Static Discharge control procedures whenever handling semiconductor products.



**20.3. SOIC8 - IMC Positioning**

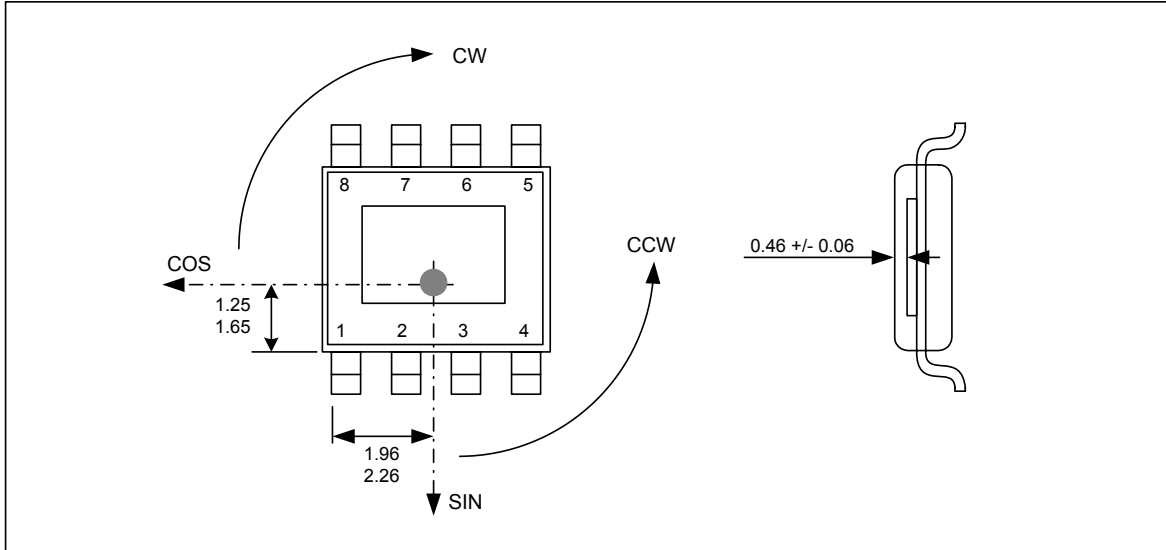

**20.4. TSSOP16 - Package Dimensions**

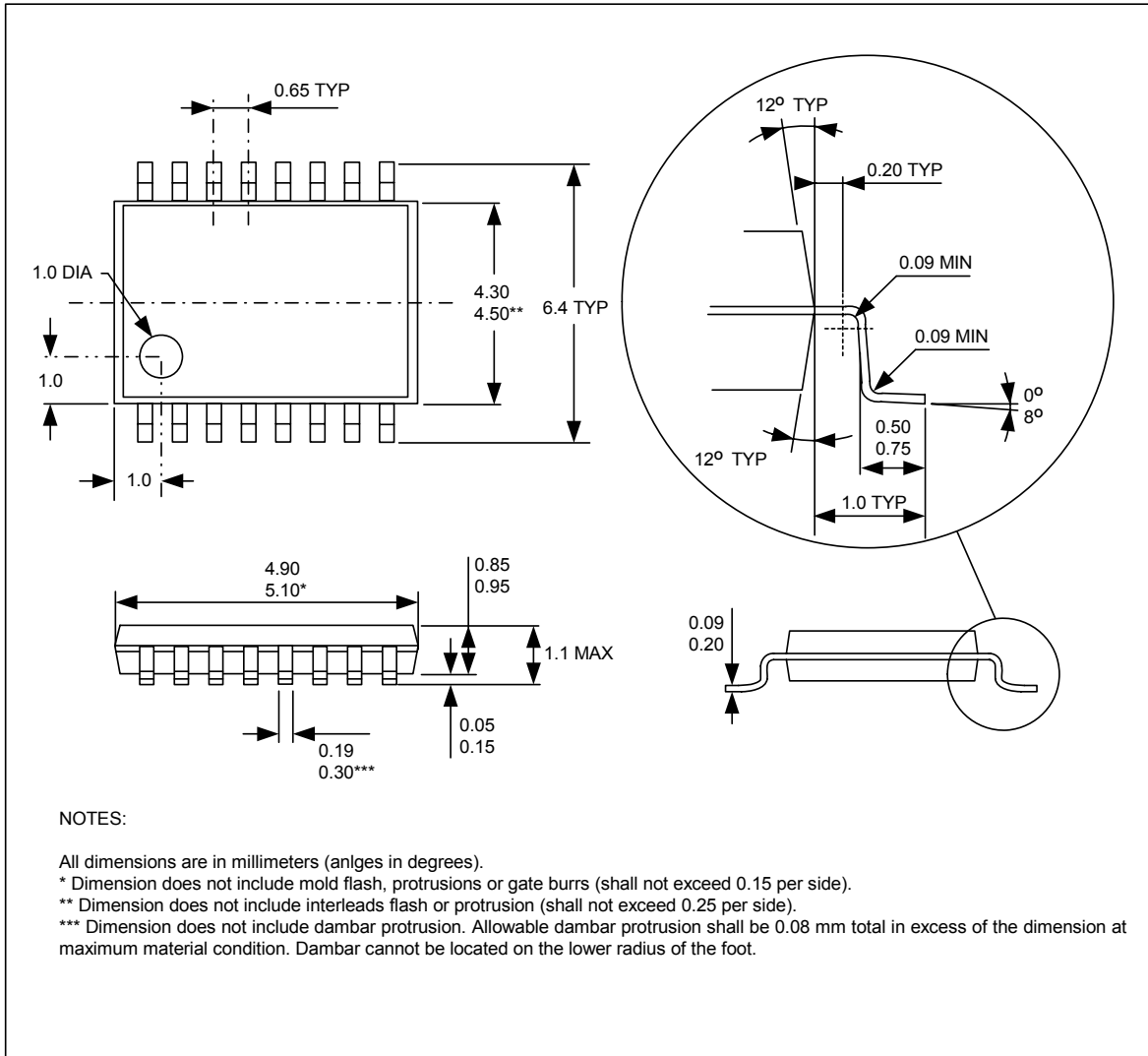

**20.5. TSSOP16 - Pinout and Marking**

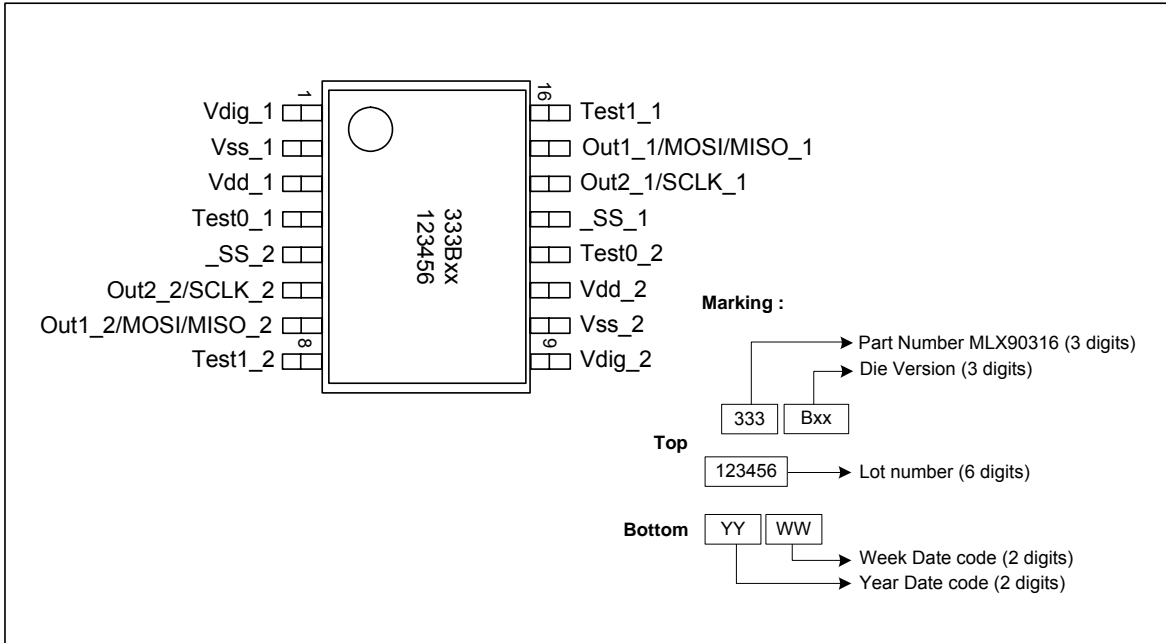

**20.6. TSSOP16 - IMC Positioning**

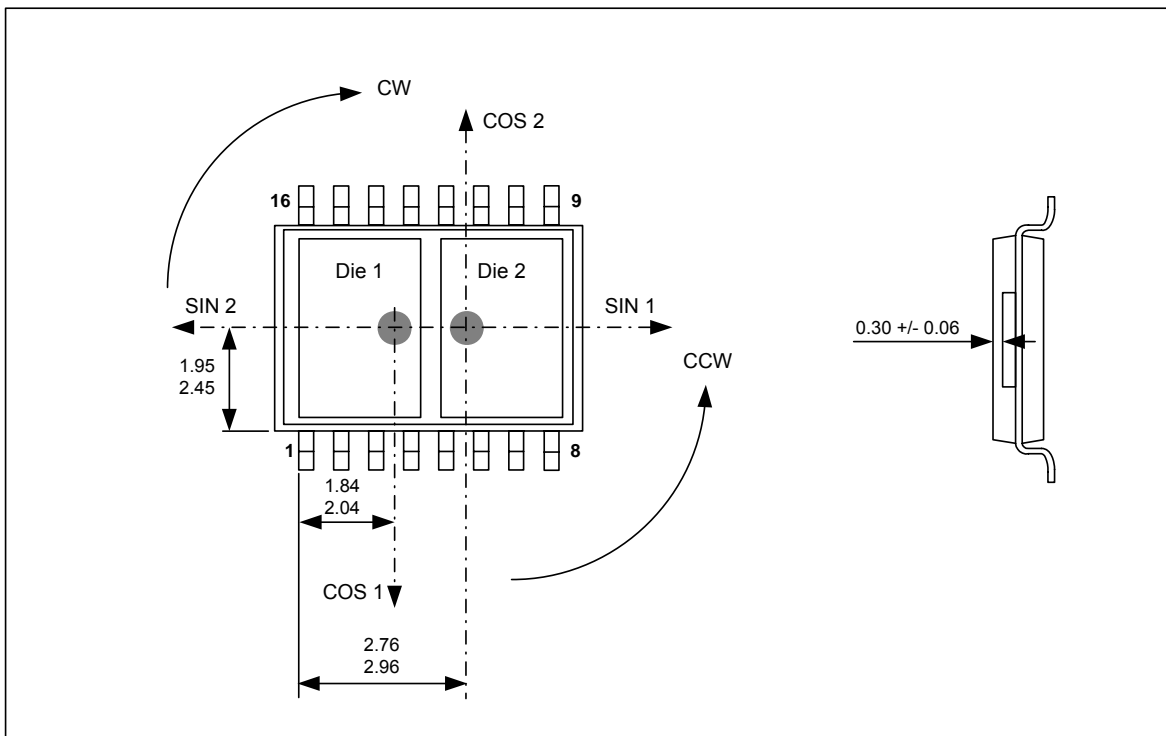

## 21. Disclaimer

Devices sold by Melexis are covered by the warranty and patent indemnification provisions appearing in its Term of Sale. Melexis makes no warranty, express, statutory, implied, or by description regarding the information set forth herein or regarding the freedom of the described devices from patent infringement. Melexis reserves the right to change specifications and prices at any time and without notice. Therefore, prior to designing this product into a system, it is necessary to check with Melexis for current information. This product is intended for use in normal commercial applications. Applications requiring extended temperature range, unusual environmental requirements, or high reliability applications, such as military, medical life-support or life-sustaining equipment are specifically not recommended without additional processing by Melexis for each application.

The information furnished by Melexis is believed to be correct and accurate. However, Melexis shall not be liable to recipient or any third party for any damages, including but not limited to personal injury, property damage, loss of profits, loss of use, interrupt of business or indirect, special incidental or consequential damages, of any kind, in connection with or arising out of the furnishing, performance or use of the technical data herein. No obligation or liability to recipient or any third party shall arise or flow out of Melexis' rendering of technical or other services.

© 2011 Melexis N.V. All rights reserved.

For the latest version of this document, go to our website at  
[www.melexis.com](http://www.melexis.com)

Or for additional information contact Melexis Direct:

Europe, Africa, Asia:  
Phone: +32 1367 0495  
E-mail: [sales\\_europe@melexis.com](mailto:sales_europe@melexis.com)

America:  
Phone: +1 603 223 2362  
E-mail: [sales\\_usa@melexis.com](mailto:sales_usa@melexis.com)

ISO/TS 16949 and ISO14001 Certified