



InvenSense Inc.

1197 Borregas Ave, Sunnyvale, CA 94089 U.S.A.
Tel: +1 (408) 988-7339 Fax: +1 (408) 988-8104
Website: www.invensense.com

Document Number: PS-MPU-6000A-00
Revision: 1.0
Release Date: 11/24/2010

MPU-6000 and MPU-6050 Product Specification Revision 1.0

CONTENTS

1	REVISION HISTORY	5
2	PURPOSE AND SCOPE	6
3	PRODUCT OVERVIEW	6
4	APPLICATIONS.....	7
5	FEATURES	8
5.1	GYROSCOPE FEATURES.....	8
5.2	ACCELEROMETER FEATURES	8
5.3	ADDITIONAL FEATURES	8
5.4	MOTION PROCESSING.....	9
5.5	CLOCKING	9
6	ELECTRICAL CHARACTERISTICS.....	10
6.1	GYROSCOPE SPECIFICATIONS	10
6.2	ACCELEROMETER SPECIFICATIONS.....	11
6.3	ELECTRICAL AND OTHER COMMON SPECIFICATIONS.....	12
6.4	ELECTRICAL SPECIFICATIONS, CONTINUED	13
6.5	ELECTRICAL SPECIFICATIONS, CONTINUED	14
6.6	ELECTRICAL SPECIFICATIONS, CONTINUED	15
6.7	I ² C TIMING CHARACTERIZATION.....	16
6.8	SPI TIMING CHARACTERIZATION (MPU-6000 ONLY)	17
6.9	ABSOLUTE MAXIMUM RATINGS	18
7	APPLICATIONS INFORMATION	19
7.1	PIN OUT AND SIGNAL DESCRIPTION.....	19
7.2	TYPICAL OPERATING CIRCUIT.....	20
7.3	BILL OF MATERIALS FOR EXTERNAL COMPONENTS	20
7.4	RECOMMENDED POWER-ON PROCEDURE	21
7.5	BLOCK DIAGRAM	22
7.6	OVERVIEW	22
7.7	THREE-AXIS MEMS GYROSCOPE WITH 16-BIT ADCs AND SIGNAL CONDITIONING.....	23
7.8	THREE-AXIS MEMS ACCELEROMETER WITH 16-BIT ADCs AND SIGNAL CONDITIONING	23
7.9	DIGITAL MOTION PROCESSOR	23
7.10	PRIMARY I ² C AND SPI SERIAL COMMUNICATIONS INTERFACES	23
7.11	AUXILIARY I ² C SERIAL INTERFACE	24
7.12	SELF-TEST.....	24



7.13	MPU-60X0 SOLUTION FOR 9-AXIS SENSOR FUSION USING I ² C INTERFACE	25
7.14	MPU-6000 USING SPI INTERFACE	26
8	PROGRAMMABLE INTERRUPTS.....	27
8.1	FREE FALL, MOTION, AND ZERO MOTION SIGNAL PATHS	28
8.2	FREE FALL INTERRUPT	28
8.3	MOTION INTERRUPT	28
8.4	ZERO MOTION INTERRUPT.....	29
9	CLOCKING	30
9.1	INTERNAL CLOCK GENERATION	30
9.2	SENSOR DATA REGISTERS	30
9.3	FIFO	30
9.4	INTERRUPTS	30
9.5	DIGITAL-OUTPUT TEMPERATURE SENSOR	31
9.6	BIAS AND LDO	31
9.7	CHARGE PUMP	31
10	DIGITAL INTERFACE	32
10.1	I ² C AND SPI (MPU-6000 ONLY) SERIAL INTERFACES	32
10.2	I ² C INTERFACE	32
10.3	I ² C COMMUNICATIONS PROTOCOL	32
10.4	I ² C TERMS	35
10.5	SPI INTERFACE (MPU-6000 ONLY)	36
11	SERIAL INTERFACE CONSIDERATIONS (MPU-6050)	37
11.1	MPU-6050 SUPPORTED INTERFACES.....	37
11.2	LOGIC LEVELS	37
11.3	LOGIC LEVELS DIAGRAM FOR AUX_VDDIO = 0	38
11.4	LOGIC LEVELS DIAGRAM FOR AUX_VDDIO = 1	39
12	ASSEMBLY	40
12.1	ORIENTATION OF AXES	40
12.2	PACKAGE DIMENSIONS	41
12.3	PCB DESIGN GUIDELINES:	42
12.4	ASSEMBLY PRECAUTIONS	43
12.4.1	GYROSCOPE SURFACE MOUNT GUIDELINES	43
12.4.2	EXPOSED DIE PAD PRECAUTIONS	43
12.4.3	TRACE ROUTING	44



12.4.4	COMPONENT PLACEMENT	44
12.4.5	PCB MOUNTING AND CROSS-AXIS SENSITIVITY	44
12.4.6	MEMS HANDLING INSTRUCTIONS	45
12.4.7	ESD CONSIDERATIONS	45
12.4.8	REFLOW SPECIFICATION	45
12.4.9	STORAGE SPECIFICATIONS	47
12.4.10	GYRO REMOVAL FROM PCB	47
12.5	PACKAGE MARKING SPECIFICATION	47
12.6	TAPE & REEL SPECIFICATION	48
12.7	LABEL	50
12.8	PACKAGING	50
13	RELIABILITY	51
13.1	QUALIFICATION TEST POLICY	51
13.2	QUALIFICATION TEST PLAN	51
14	ENVIRONMENTAL COMPLIANCE.....	52

PRELIMINARY



1 Revision History

Revision Date	Revision	Description
11/24/2010	1.0	First revision of MPU-60X0 Product Specification

PRELIMINARY

2 Purpose and Scope

This product specification provides preliminary information regarding the electrical specification and design related information for the MPU-6000™ and MPU-6050™, collectively called the MPU-60X0™ or MPU™.

Electrical characteristics are based upon design analysis and simulation results only. Specifications are subject to change without notice. Final specifications will be updated based upon characterization of production silicon. For references to register map and descriptions of individual registers, please refer to MPU-6000 Register Map and Descriptions document.

3 Product Overview

The MPU-60X0 Motion Processing Unit (MPU™) is the world's first motion processing solution with integrated 9-axis sensor fusion for handset and tablet applications, game controllers, motion pointer remote controls, and other consumer devices. The MPU-60X0 has an embedded 3-axis MEMS gyroscope, 3-axis MEMS accelerometer and Digital Motion Processor™ (DMP) hardware accelerator engine with an auxiliary I²C port that interfaces to third party digital sensors, such as magnetometers. Interfacing with a 3-axis magnetometer delivers a complete 9-axis sensor fusion output to the MPU's primary I²C or SPI port. (SPI is available on MPU-6000 only). This combines acceleration and rotational motion plus heading information into a single data stream for the application. This motion processing technology integration provides a smaller footprint and has inherent cost advantages compared to discrete gyroscope plus accelerometer solutions. The MPU-60X0 is also designed to interface with multiple non-inertial digital sensors, such as pressure sensors, on its auxiliary I²C port. The MPU-60X0 is a second generation motion processor and is footprint compatible with the MPU-30X0 family.

The MPU-60X0 features three 16-bit analog-to-digital converters (ADCs) for digitizing the gyroscope outputs and three 16-bit ADCs for digitizing the accelerometer outputs. For precision tracking of both fast and slow motions, the parts feature a user-programmable gyroscope full-scale range of ± 250 , ± 500 , ± 1000 , and $\pm 2000^\circ/\text{sec}$ (dps) and a user-programmable accelerometer full-scale range of $\pm 2g$, $\pm 4g$, $\pm 8g$, and $\pm 16g$.

An on-chip 1024 Byte FIFO helps lower system power consumption by allowing the system processor to read the sensor data in bursts and then enter a low-power mode as the FIFO collects more data. With all the necessary on-chip processing and sensor components required to support many motion-based use cases, the MPU-60X0 uniquely supports a variety of advanced motion-based applications entirely on-chip and therefore is instrumental in enabling low-power motion processing in portable applications with reduced processing requirements for the system processor. By providing an integrated sensor fusion output, the DMP in the MPU-60X0 offloads the intensive motion processing computation requirements from the system processor, minimizing the need for frequent polling of the motion sensor output.

Communication with all registers of the device is performed using either I²C at 400kHz or SPI at 1MHz (MPU-6000 only). For applications requiring faster communications, reading of the sensor and interrupt registers may be performed using SPI at 20MHz (MPU-6000 only). Additional features include an embedded temperature sensor and an on-chip oscillator with $\pm 1\%$ variation over the operating temperature range.

By leveraging its patented and volume-proven Nasiri-Fabrication platform, which integrates MEMS wafers with companion CMOS electronics through wafer-level bonding, InvenSense has driven the MPU-60X0 package size down to a revolutionary footprint of 4x4x0.9mm (QFN), while providing the highest performance, lowest noise, and the lowest cost semiconductor packaging required for handheld consumer electronic devices. The part features a robust 10,000g shock tolerance, and has programmable low-pass filters for the gyroscopes, accelerometers, and the on-chip temperature sensor.

For power supply flexibility, the MPU-60X0 operates from VDD power supply voltages of $2.5V \pm 5\%$, $3.0V \pm 5\%$, or $3.3V \pm 5\%$. Additionally, the MPU-6050 provides a VLOGIC reference pin (in addition to its analog supply pin, VDD), which sets the logic levels of its I²C interface. The VLOGIC voltage may be $1.8V \pm 5\%$ or VDD.

The MPU-6000 and MPU-6050 are identical, except that the MPU-6050 supports the I²C serial interface only, and has a separate VLOGIC reference pin. The MPU-6000 supports both I²C and SPI interfaces and has a single supply pin, VDD, which is both the device's logic reference supply and the analog supply for the part. The table below outlines these differences:

Primary Differences between MPU-6000 and MPU-6050

Part / Item	MPU-6000	MPU-6050
VDD	2.5V±5%, 3.0V±5%, or 3.3V±5%.	2.5V±5%, 3.0V±5%, or 3.3V±5%.
VLOGIC	n/a	1.71V to VDD
Serial Interfaces Supported	I ² C, SPI	I ² C
Pin 8	/CS	VLOGIC
Pin 9	AD0/SDO	AD0
Pin 23	SCL/SCLK	SCL
Pin 24	SDA/SDI	SDA

4 Applications

- *BlurFree*[™] technology (for Video/Still Image Stabilization)
- *AirSign*[™] technology (for Security/Authentication)
- *TouchAnywhere*[™] technology (for “no touch” UI Application Control/Navigation)
- *MotionCommand*[™] technology (for Gesture Short-cuts)
- Motion-enabled game and application framework
- InstantGesture[™] iG[™] gesture recognition
- Location based services, points of interest, and dead reckoning
- Handset and portable gaming
- Motion-based game controllers
- 3D remote controls for Internet connected DTVs and set top boxes, 3D mice
- Wearable sensors for health, fitness and sports
- Toys

5 Features

5.1 Gyroscope Features

The triple-axis MEMS gyroscope in the MPU-60X0 includes a wide range of features:

- Digital-output X-, Y-, and Z-Axis angular rate sensors (gyroscopes) with a user-programmable full-scale range of ± 250 , ± 500 , ± 1000 , and $\pm 2000^\circ/\text{sec}$
- External sync signal connected to the FSYNC pin supports image, video and GPS synchronization
- Integrated 16-bit ADCs provide simultaneous sampling of gyros
- Enhanced bias and sensitivity temperature stability reduces the need for user calibration
- Improved low-frequency noise performance
- Digitally-programmable low-pass filter
- Gyroscope operating current: 5mA
- Standby current: 5 μ A
- Factory calibrated sensitivity scale factor
- User self-test

5.2 Accelerometer Features

The triple-axis MEMS accelerometer in MPU-60X0 includes a wide range of features:

- Digital-output tri-axis accelerometer with a programmable full scale range of $\pm 2g$, $\pm 4g$, $\pm 8g$ and $\pm 16g$
- Integrated 16-bit ADCs provide simultaneous sampling of accelerometers while requiring no external multiplexer
- Accel normal operating current: 500 μ A
- Low power accelerometer mode current: 40 μ A at 10 Hz
- Orientation detection and signaling
- Tap detection
- User-programmable interrupts
- Free-fall interrupt
- High-G interrupt
- Zero-motion/Motion interrupt
- User self test

5.3 Additional Features

The MPU-60X0 includes the following additional features:

- 9-Axis sensor fusion via on-chip Digital Motion Processor (DMP)
- Auxiliary master I²C bus for reading data from external sensors (e.g., magnetometer)
- 5.5mA operating current for all 6 axes
- VDD supply voltages of 2.5V \pm 5%, 3.0V \pm 5%, 3.3V \pm 5%
- Flexible VLOGIC reference voltage allows for multiple I²C interface voltages (MPU-6050 only)
- Smallest and thinnest package for portable devices: 4x4x0.9mm QFN
- Minimal cross-axis sensitivity between the accelerometer and gyroscope axes
- 1024 byte FIFO reduces power consumption by allowing host processor to read the data in bursts and then go into a low-power mode as the FIFO collects more data
- Digital-output temperature sensor
- User-programmable digital filters for gyroscope, accelerometer, and temp sensor
- 10,000 g shock tolerant
- 400kHz Fast Mode I²C for communicating with all registers

- 1MHz SPI serial interface for communicating with all registers (MPU-6000 only)
- 20MHz SPI serial interface for reading of sensor and interrupt registers (MPU-6000 only)
- MEMS structure hermetically sealed and bonded at wafer level
- RoHS and Green compliant

5.4 Motion Processing

- Internal Digital Motion Processing™ (DMP™) engine supports 3D motion processing and gesture recognition algorithms
- MPU-60X0 collects the gyroscope and accelerometer data while synchronizing data sampling at a user defined rate. The total data set obtained by the MPU-60X0 includes 3-axis gyroscope data and 3-axis accelerometer data, and temperature data. The MPU calculated output can also include compass data from a digital 3-axis third party magnetometer.
- FIFO buffers the complete data set, reducing timing requirements on the system processor and saving power by letting the processor burst read the FIFO data, and then enter a low-power sleep mode while the MPU collects more data.
- Programmable interrupt supports features such as gesture recognition, panning, zooming, scrolling, zero-motion detection, tap detection, and shake detection
- Programmable low-pass filters.
- Low-power pedometer functionality allows the host processor to sleep while the DMP maintains the step count.

5.5 Clocking

- On-chip timing generator $\pm 1\%$ frequency variation over full temperature range
- Optional external clock inputs of 32.768kHz or 19.2MHz

6 Electrical Characteristics

6.1 Gyroscope Specifications

VDD = 2.5V±5%, 3.0V±5%, or 3.3V±5%, VLOGIC (MPU-6050 only) = 1.8V±5% or VDD, T_A = 25°C

PARAMETER	CONDITIONS	MIN	TYP	MAX	UNITS	NOTES
GYROSCOPE SENSITIVITY						
Full-Scale Range	FS_SEL=3		±2000		°/s	
	FS_SEL=2		±1000		°/s	
	FS_SEL=1		±500		°/s	
	FS_SEL=0		±250		°/s	
Gyroscope ADC Word Length			16		Bits	
Sensitivity Scale Factor	FS_SEL=0		131		LSB/(°/s)	
	FS_SEL=1		65.5		LSB/(°/s)	
	FS_SEL=2		32.8		LSB/(°/s)	
	FS_SEL=3		16.4		LSB/(°/s)	
Sensitivity Scale Factor Tolerance	25°C	-3		+3	%	
Sensitivity Scale Factor Variation Over Temperature			±2		%	
Nonlinearity	Best fit straight line; 25°C		0.2		%	
Cross-Axis Sensitivity			±2		%	
GYROSCOPE ZERO-RATE OUTPUT (ZRO)						
Initial ZRO Tolerance	25°C		±20		°/s	
ZRO Variation Over Temperature	-40°C to +85°C		±20		°/s	
Power-Supply Sensitivity (1-10Hz)	Sine wave, 100mVpp; VDD=2.5V		0.2		°/s	
Power-Supply Sensitivity (10 - 250Hz)	Sine wave, 100mVpp; VDD=2.5V		0.2		°/s	
Power-Supply Sensitivity (250Hz - 100kHz)	Sine wave, 100mVpp; VDD=2.5V		4		°/s	
Linear Acceleration Sensitivity	Static		0.1		°/s/g	
GYROSCOPE NOISE PERFORMANCE	FS_SEL=0					
Total RMS Noise	DLPCFG=2 (100Hz)		0.05		°/s-rms	
Low-frequency RMS noise	Bandwidth 1Hz to 10Hz		0.033		°/s-rms	
Rate Noise Spectral Density	At 10Hz		0.005		°/s/√Hz	
GYROSCOPE MECHANICAL FREQUENCIES						
X-Axis		30	33	36	kHz	
Y-Axis		27	30	33	kHz	
Z-Axis		24	27	30	kHz	
SELF TEST RESPONSE						
	X, Y, and Z axes		50		°/s	
OUTPUT DATA RATE						
	Programmable	4		8,000	Hz	
GYROSCOPE START-UP TIME						
ZRO Settling	DLPCFG=0 to ±1°/s of Final		30		ms	

6.2 Accelerometer Specifications

VDD = 2.5V±5%, 3.0V±5%, or 3.3V±5%, VLOGIC (MPU-6050 only) = 1.8V±5% or VDD, T_A = 25°C

PARAMETER	CONDITIONS	MIN	TYP	MAX	UNITS	NOTES
ACCELEROMETER SENSITIVITY						
Full-Scale Range	±2g mode		±2		g	
	±4g mode		±4		g	
	±8g mode		±8		g	
	±16g mode		±16		g	
ADC Word Length	Output in two's complement format		16		Bits	
Sensitivity Scale Factor	±2g mode		0.06		mg/LSB	
	±4g mode		0.12		mg/LSB	
	±8g mode		0.24		mg/LSB	
	±16g mode		0.49		mg/LSB	
Initial Calibration Tolerance			±3		%	
Sensitivity Change vs. Temperature	(±2g)		±0.02		%/°C	
Nonlinearity	Best Fit Straight Line		0.5		%	
Cross-Axis Sensitivity			±2		%	
ZERO-G OUTPUT						
Initial Calibration Tolerance			±50		mg	
Zero-G Level Change vs. Temperature			±1		mg/°C	
SELF TEST RESPONSE						
	X, Y, and Z axes		0.5		g	
NOISE PERFORMANCE						
Power Spectral Density	@10Hz		350		μg/√Hz	
LOW PASS FILTER RESPONSE						
	Programmable Range	5		250	Hz	
OUTPUT DATA RATE						
	Programmable Range	4		1,000	Hz	

6.3 Electrical and Other Common Specifications

VDD = 2.5V±5%, 3.0V±5%, or 3.3V±5%, VLOGIC (MPU-6050 only) = 1.8V±5% or VDD, T_A = 25°C

PARAMETER	CONDITIONS	MIN	TYP	MAX	Units	Notes
VDD POWER SUPPLY						
Operating Voltages			2.5±5%		V	
			3.0±5%		V	
			3.3±5%		V	
Normal Operating Current	Gyroscope + Accelerometer + DMP		5.5		mA	
	Gyroscope + DMP (Accelerometer disabled)		5.0		mA	
	Accelerometer only (DMP & Gyroscope disabled)		500		µA	
Accelerometer Low Power Mode Current	10Hz update rate		40		µA	
Full-Chip Idle Mode Supply Current			5		µA	
Power Supply Ramp Rate	Monotonic ramp. Ramp rate is 10% to 90% of the final value			100	ms	
VLOGIC REFERENCE VOLTAGE	MPU-6050 only					
Voltage Range	VLOGIC must be ≤VDD at all times	1.71		VDD	V	
Power Supply Ramp Rate	Monotonic ramp. Ramp rate is 10% to 90% of the final value			3	ms	
Normal Operating Current			100		µA	
START-UP TIME FOR REGISTER READ/WRITE			20	100	ms	
TEMPERATURE RANGE						
Specified Temperature Range	Performance parameters are not applicable beyond Specified Temperature Range	-40		+85	°C	
SERIAL INTERFACE						
SPI Operating Frequency, All Registers Read/Write	MPU-6000 only, Low Speed Characterization		100 ±10%		kHz	
	MPU-6000 only, High Speed Characterization		1 ±10%		MHz	
SPI Operating Frequency, Sensor and Interrupt Registers Read Only	MPU-6000 only		20 ±10%		MHz	
I ² C Operating Frequency	All registers, Fast-mode			400	kHz	
	All registers, Standard-mode			100	kHz	

6.4 Electrical Specifications, Continued

VDD = 2.5V±5%, 3.0V±5%, or 3.3V±5%, VLOGIC (MPU-6050 only) = 1.8V±5% or VDD, T_A = 25°C

PARAMETER	CONDITIONS	MIN	TYP	MAX	Units	Notes
TEMPERATURE SENSOR						
Range			-40 to +85		°C	
Sensitivity	Untrimmed		325		LSB/°C	
Temperature Offset	35°C		-3079		LSB	
Linearity	Best fit straight line (-40°C to +85°C)		±1		°C	
I²C ADDRESS						
	AD0 = 0		1101000			
	AD0 = 1		1101001			
DIGITAL INPUTS (SDI/SDA, SDO/AD0, SCLK/SCL, FSYNC, /CS, CLKIN)						
V _{IH} , High Level Input Voltage	MPU-6000	0.7*VDD			V	
	MPU-6050	0.7*VLOGIC			V	
V _{IL} , Low Level Input Voltage	MPU-6000			0.3*VDD	V	
	MPU-6050			0.3*VLOGIC	V	
C _i , Input Capacitance			< 5		pF	
DIGITAL OUTPUT (INT)						
V _{OH} , High Level Output Voltage	R _{LOAD} =1MΩ; MPU-6000	0.9*VDD			V	
	R _{LOAD} =1MΩ; MPU-6050	0.9*VLOGIC			V	
V _{OL1} , LOW-Level Output Voltage	R _{LOAD} =1MΩ; MPU-6000			0.1*VDD	V	
	R _{LOAD} =1MΩ; MPU-6050			0.1*VLOGIC	V	
V _{OL,INT1} , INT Low-Level Output Voltage	OPEN=1, 0.3mA sink Current			0.1	V	
Output Leakage Current	OPEN=1		100		nA	
t _{INT} , INT Pulse Width	LATCH_INT_EN=0		50		μs	

6.5 Electrical Specifications, Continued

Typical Operating Circuit of Section 7.2, VDD = 2.5V±5%, 3.0V±5%, or 3.3V±5%, VLOGIC (MPU-6050 only) = 1.8V±5% or VDD, T_A = 25°C

Parameters	Conditions	Typical	Units	Notes
Primary I²C I/O (SCL, SDA)				
V _{IL} , LOW-Level Input Voltage	MPU-6000	-0.5 to 0.3*VDD	V	
V _{IH} , HIGH-Level Input Voltage	MPU-6000	0.7*VDD to VDD + 0.5V	V	
V _{hys} , Hysteresis	MPU-6000	0.1*VDD	V	
V _{IL} , LOW Level Input Voltage	MPU-6050	-0.5V to 0.3*VLOGIC	V	
V _{IH} , HIGH-Level Input Voltage	MPU-6050	0.7*VLOGIC to VLOGIC + 0.5V	V	
V _{hys} , Hysteresis	MPU-6050	0.1*VLOGIC	V	
V _{OL1} , LOW-Level Output Voltage	3mA sink current	0 to 0.4	V	
I _{OL} , LOW-Level Output Current	V _{OL} = 0.4V	3	mA	
	V _{OL} = 0.6V	5	mA	
Output Leakage Current		100	nA	
t _{of} , Output Fall Time from V _{IHmax} to V _{ILmax}	C _b bus capacitance in pF	20+0.1C _b to 250	ns	
C _I , Capacitance for Each I/O pin		< 10	pF	
Auxiliary I²C I/O (AUX_CL, AUX_DA)	MPU-6050: AUX_VDDIO=0			
V _{IL} , LOW-Level Input Voltage		-0.5V to 0.3*VLOGIC	V	
V _{IH} , HIGH-Level Input Voltage		0.7*VLOGIC to VLOGIC + 0.5V	V	
V _{hys} , Hysteresis		0.1*VLOGIC	V	
V _{OL1} , LOW-Level Output Voltage	VLOGIC > 2V; 1mA sink current	0 to 0.4	V	
V _{OL3} , LOW-Level Output Voltage	VLOGIC < 2V; 1mA sink current	0 to 0.2*VLOGIC	V	
I _{OL} , LOW-Level Output Current	V _{OL} = 0.4V	1	mA	
	V _{OL} = 0.6V	1	mA	
Output Leakage Current		100	nA	
t _{of} , Output Fall Time from V _{IHmax} to V _{ILmax}	C _b bus capacitance in pF	20+0.1C _b to 250	ns	
C _I , Capacitance for Each I/O pin		< 10	pF	
Auxiliary I²C I/O (AUX_CL, AUX_DA)	MPU-6050: AUX_VDDIO=1; MPU-6000			
V _{IL} , LOW-Level Input Voltage		-0.5 to 0.3*VDD	V	
V _{IH} , HIGH-Level Input Voltage		0.7*VDD to VDD+0.5V	V	
V _{hys} , Hysteresis		0.1*VDD	V	
V _{OL1} , LOW-Level Output Voltage	1mA sink current	0 to 0.4	V	
I _{OL} , LOW-Level Output Current	V _{OL} = 0.4V	1	mA	
	V _{OL} = 0.6V	1	mA	
Output Leakage Current		100	nA	
t _{of} , Output Fall Time from V _{IHmax} to V _{ILmax}	C _b bus cap. in pF	20+0.1C _b to 250	ns	
C _I , Capacitance for Each I/O pin		< 10	pF	

6.6 Electrical Specifications, Continued

Typical Operating Circuit of Section 7.2, VDD = 2.5V±5%, 3.0V±5%, or 3.3V±5%, VLOGIC (MPU-6050 only) = 1.8V±5% or VDD, T_A = 25°C

Parameters	Conditions	Min	Typical	Max	Units	Notes
INTERNAL CLOCK SOURCE	CLK_SEL=0,1,2,3					
Gyroscope Sample Rate, Fast	DLPFCFG=0 SAMPLERATEDIV = 0		8		kHz	
Gyroscope Sample Rate, Slow	DLPFCFG=1,2,3,4,5, or 6 SAMPLERATEDIV = 0		1		kHz	
Accelerometer Sample Rate			1		kHz	
Reference Clock Output	CLKOUTEN = 1		1.024		MHz	
Clock Frequency Initial Tolerance	CLK_SEL=0, 25°C	-5		+5	%	
Frequency Variation over Temperature	CLK_SEL=1,2,3; 25°C	-1		+1	%	
	CLK_SEL=0		-15 to +10		%	
	CLK_SEL=1,2,3		±1		%	
PLL Settling Time	CLK_SEL=1,2,3		1		ms	
EXTERNAL 32.768kHz CLOCK	CLK_SEL=4					
External Clock Frequency			32.768		kHz	
External Clock Allowable Jitter	Cycle-to-cycle rms		1 to 2		µs	
Gyroscope Sample Rate, Fast	DLPFCFG=0 SAMPLERATEDIV = 0		8.192		kHz	
Gyroscope Sample Rate, Slow	DLPFCFG=1,2,3,4,5, or 6 SAMPLERATEDIV = 0		1.024		kHz	
Accelerometer Sample Rate			1.024		kHz	
Reference Clock Output	CLKOUTEN = 1		1.0486		MHz	
PLL Settling Time			1		ms	
EXTERNAL 19.2MHz CLOCK	CLK_SEL=5					
External Clock Frequency			19.2		MHz	
Gyroscope Sample Rate	Full programmable range	3.9		8000	Hz	
Gyroscope Sample Rate, Fast Mode	DLPFCFG=0 SAMPLERATEDIV = 0		8		kHz	
Gyroscope Sample Rate, Slow Mode	DLPFCFG=1,2,3,4,5, or 6 SAMPLERATEDIV = 0		1		kHz	
Accelerometer Sample Rate			1		kHz	
Reference Clock Output	CLKOUTEN = 1		1.024		MHz	
PLL Settling Time			1		ms	

6.7 I²C Timing Characterization

Typical Operating Circuit of Section 7.2, VDD = 2.5V±5%, 3.0V±5%, or 3.3V±5%, VLOGIC (MPU-6050 only) = 1.8V±5% or VDD, T_A = 25°C

Parameters	Conditions	Min	Typical	Max	Units	Notes
I²C TIMING						
f _{SCL} , SCL Clock Frequency	I ² C FAST-MODE C _b bus cap. from 10 to 400pF			400	kHz	
t _{HD,STA} , (Repeated) START Condition Hold Time		0.6			μs	
t _{LOW} , SCL Low Period		1.3			μs	
t _{HIGH} , SCL High Period		0.6			μs	
t _{SU,STA} , Repeated START Condition Setup Time		0.6			μs	
t _{HD,DAT} , SDA Data Hold Time		0			μs	
t _{SU,DAT} , SDA Data Setup Time		100			ns	
t _r , SDA and SCL Rise Time		20+0.1C _b		300	ns	
t _f , SDA and SCL Fall Time		20+0.1C _b		300	ns	
t _{SU,STO} , STOP Condition Setup Time		0.6			μs	
t _{BUF} , Bus Free Time Between STOP and START Condition		1.3			μs	
C _b , Capacitive Load for each Bus Line				< 400	pF	
t _{VD,DAT} , Data Valid Time					0.9	μs
t _{VD,ACK} , Data Valid Acknowledge Time					0.9	μs

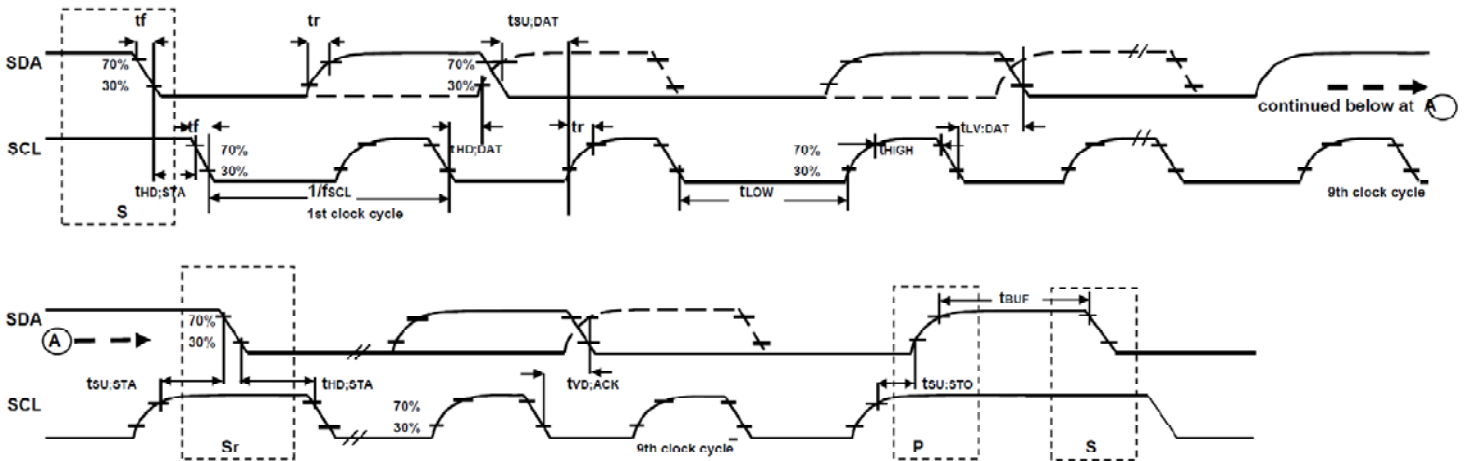

I²C Bus Timing Diagram

6.8 SPI Timing Characterization (MPU-6000 only)

Typical Operating Circuit of Section 7.2, $V_{DD} = 2.5V \pm 5\%$, $3.0V \pm 5\%$, or $3.3V \pm 5\%$, VLOGIC (MPU-6050 only) = $1.8V \pm 5\%$ or V_{DD} , $T_A = -40^\circ\text{C}$ to $+85^\circ\text{C}$, unless otherwise noted.

Parameters	Conditions	Min	Typical	Max	Units	Notes
SPI TIMING						
f_{SCLK} , SCLK Clock Frequency				1	MHz	
t_{LOW} , SCLK Low Period		400			ns	
t_{HIGH} , SCLK High Period		400			ns	
$t_{\text{SU:CS}}$, CS Setup Time		8			ns	
$t_{\text{HD:CS}}$, CS Hold Time		500			ns	
$t_{\text{SU:SDI}}$, SDI Setup Time		11			ns	
$t_{\text{HD:SDI}}$, SDI Hold Time		7			ns	
$t_{\text{VD:SDO}}$, SDO Valid Time	$C_{\text{load}} = 20\text{pF}$			100	ns	
$t_{\text{HD:SDO}}$, SDO Hold Time	$C_{\text{load}} = 20\text{pF}$	4			ns	
$t_{\text{DIS:SDO}}$, SDO Output Disable Time				10	ns	

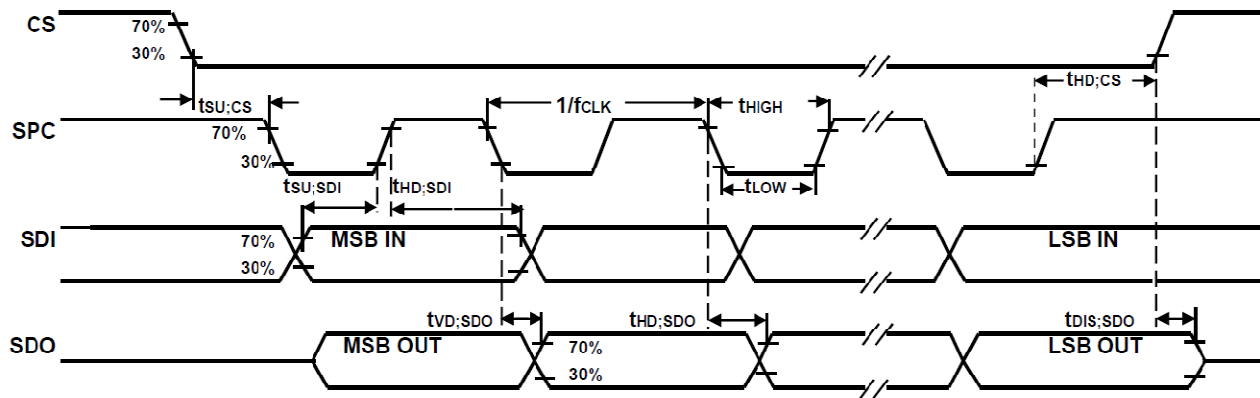
SPI Bus Timing Diagram

6.9 Absolute Maximum Ratings

Stress above those listed as “Absolute Maximum Ratings” may cause permanent damage to the device. These are stress ratings only and functional operation of the device at these conditions is not implied. Exposure to the absolute maximum ratings conditions for extended periods may affect device reliability.

Parameter	Rating
Supply Voltage, VDD	-0.5V to +6V
VLOGIC Input Voltage Level (MPU-6050)	-0.5V to VDD + 0.5V
REGOUT	-0.5V to 2V
Input Voltage Level (CLKIN, AUX_DA, AD0, FSYNC, INT, SCL, SDA)	-0.5V to VDD + 0.5V
CPOUT (2.5V ≤ VDD ≤ 3.6V)	-0.5V to 30V
Acceleration (Any Axis, unpowered)	10,000g for 0.3ms
Operating Temperature Range	-40°C to +105°C
Storage Temperature Range	-40°C to +125°C
Electrostatic Discharge (ESD) Protection	2kV (HBM); 200V (MM)
Latch-up	60mA @ 125°C JEDEC Condition “B”

7 Applications Information

7.1 Pin Out and Signal Description

Pin Number	MPU-6000	MPU-6050	Pin Name	Pin Description
1	Y	Y	CLKIN	Optional external reference clock input. Connect to GND if unused.
6	Y	Y	AUX_DA	I ² C master serial data, for connecting to external sensors
7	Y	Y	AUX_CL	I ² C Master serial clock, for connecting to external sensors
8	Y		/CS	SPI chip select (0=SPI mode)
8		Y	VLOGIC	Digital I/O supply voltage
9	Y		AD0 / SDO	I ² C Slave Address LSB (AD0); SPI serial data output (SDO)
9		Y	AD0	I ² C Slave Address LSB (AD0)
10	Y	Y	REGOUT	Regulator filter capacitor connection
11	Y	Y	FSYNC	Frame synchronization digital input
12	Y	Y	INT	Interrupt digital output (totem pole or open-drain)
13	Y	Y	VDD	Power supply voltage and Digital I/O supply voltage
18	Y	Y	GND	Power supply ground
19, 21, 22	Y	Y	RESV	Reserved. Do not connect.
20	Y	Y	CPOUT	Charge pump capacitor connection
23	Y		SCL / SCLK	I ² C serial clock (SCL); SPI serial clock (SCLK)
23		Y	SCL	I ² C serial clock (SCL)
24	Y		SDA / SDI	I ² C serial data (SDA); SPI serial data input (SDI)
24		Y	SDA	I ² C serial data (SDA)
2, 3, 4, 5, 14, 15, 16, 17	Y	Y	NC	Not internally connected. May be used for PCB trace routing.

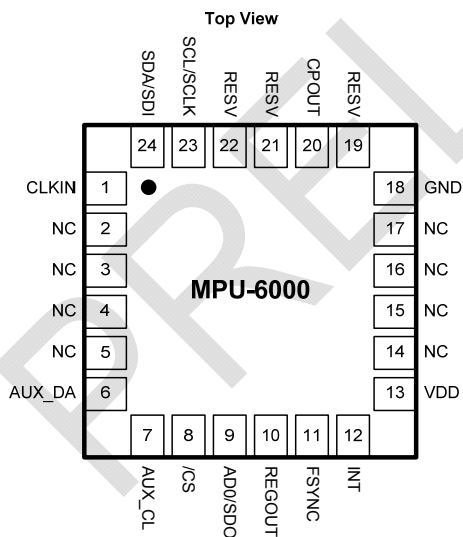

QFN Package
24-pin, 4mm x 4mm x 0.9mm

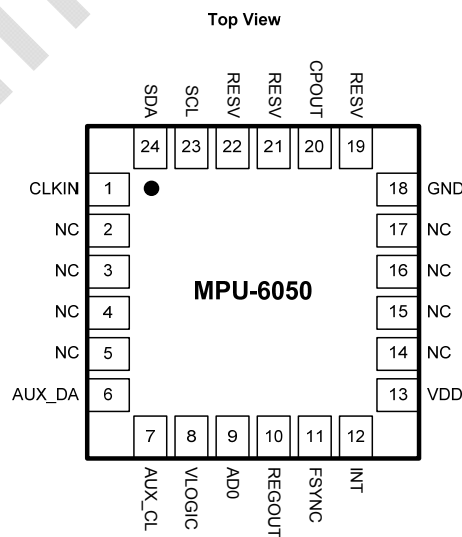

QFN Package
24-pin, 4mm x 4mm x 0.9mm

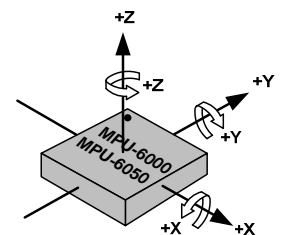

Orientation of Axes of Sensitivity and
Polarity of Rotation

7.2 Typical Operating Circuit

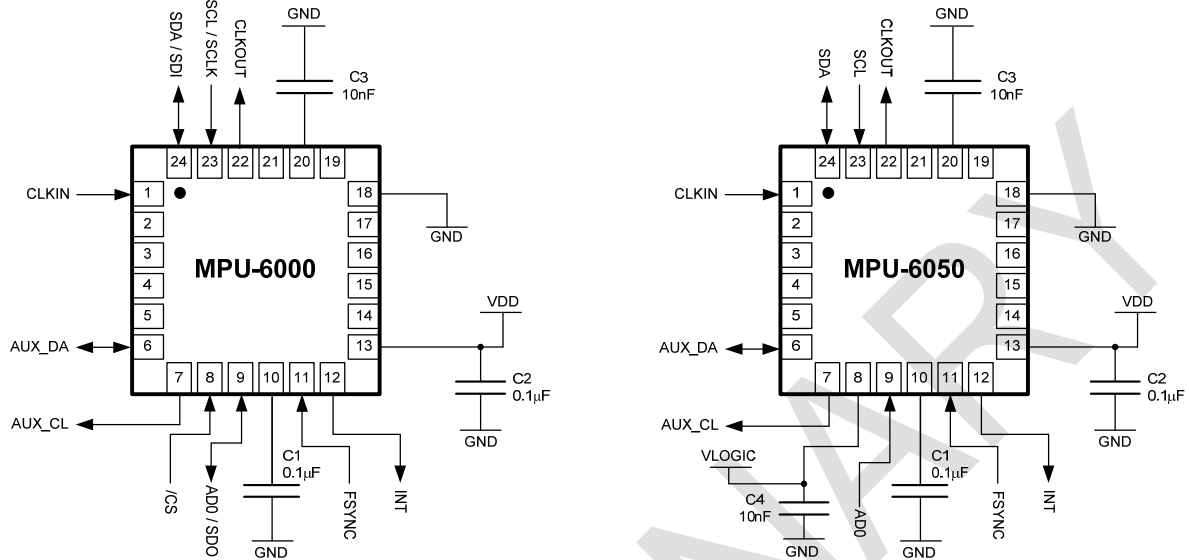

Typical Operating Circuits

7.3 Bill of Materials for External Components

Component	Label	Specification	Quantity
Regulator Filter Capacitor (Pin 10)	C1	Ceramic, X7R, 0.1µF ±10%, 2V	1
VDD Bypass Capacitor (Pin 13)	C2	Ceramic, X7R, 0.1µF ±10%, 4V	1
Charge Pump Capacitor (Pin 20)	C3	Ceramic, X7R, (10nF or 2.2nF**) ±10%, 50V	1
VLOGIC Bypass Capacitor (Pin 8)	C4*	Ceramic, X7R, 10nF ±10%, 4V	1

* MPU-6050 Only.

** Currently, the part has been characterized only with 10nF capacitor. Characterization with a 2.2nF value is pending.

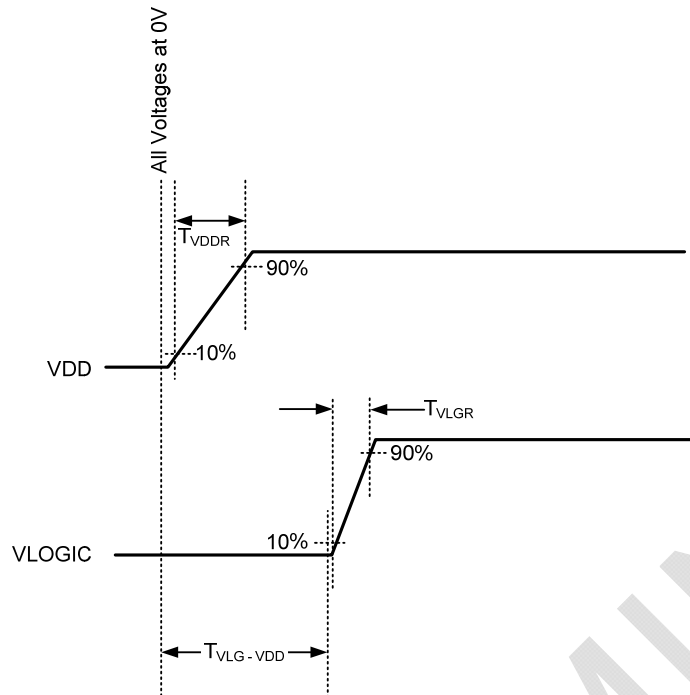
7.4 Recommended Power-on Procedure

Power-Up Sequencing

1. T_{VDDR} is VDD rise time: Time for VDD to rise from 10% to 90% of its final value
2. T_{VDDR} is $\leq 100\text{msec}$
3. T_{VLGR} is VLOGIC rise time: Time for VLOGIC to rise from 10% to 90% of its final value
4. T_{VLGR} is $\leq 3\text{msec}$
5. $T_{VLG-VDD}$ is the delay from the start of VDD ramp to the start of VLOGIC rise
6. $T_{VLG-VDD}$ is ≥ 0 ; VLOGIC amplitude must always be \leq VDD amplitude
7. VDD and VLOGIC must be monotonic ramps

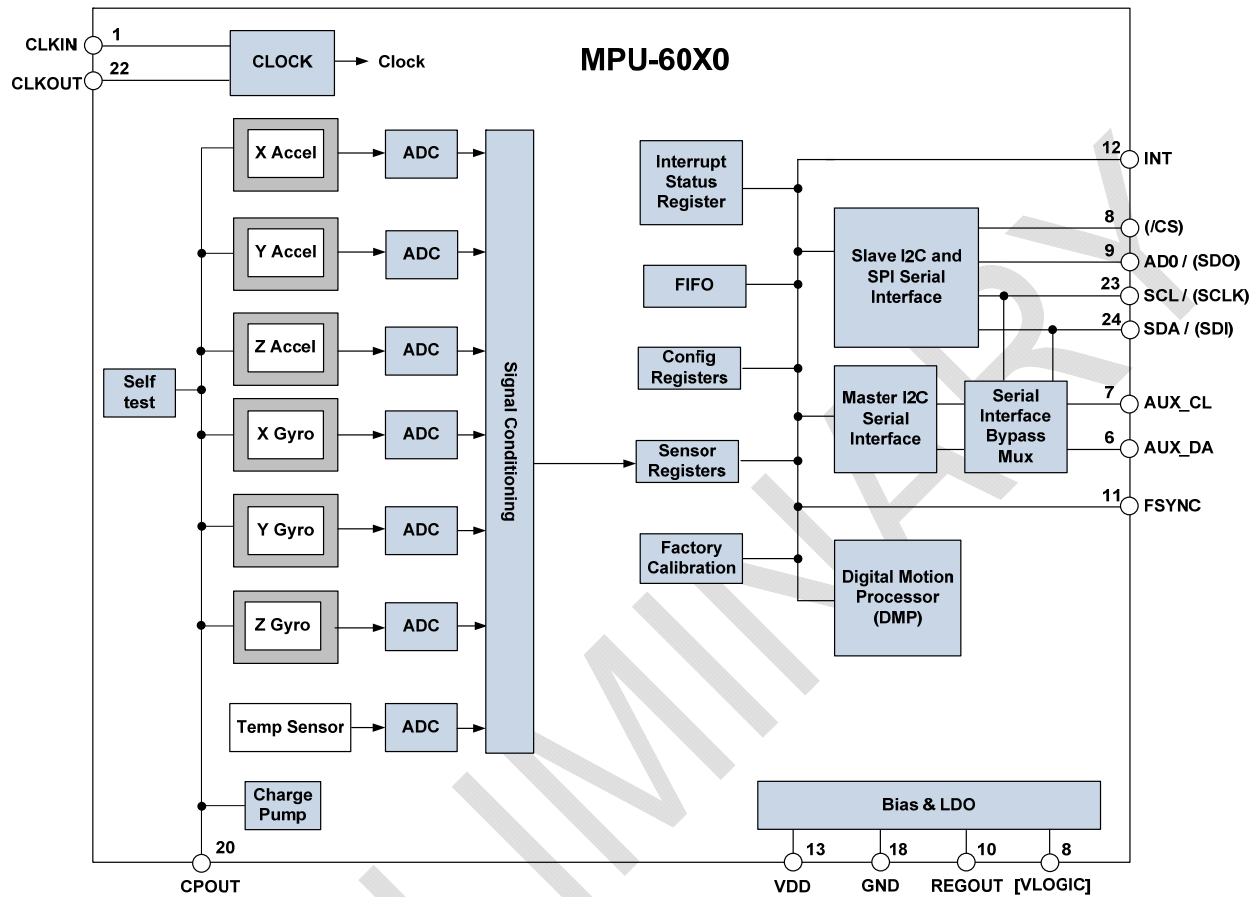
7.5 Block Diagram



Note: Pin names in round brackets () apply only to MPU-6000
 Pin names in square brackets [] apply only to MPU-6050

7.6 Overview

The MPU-60X0 is comprised of the following key blocks and functions:

- Three-axis MEMS rate gyroscope sensor with 16-bit ADCs and signal conditioning
- Three-axis MEMS accelerometer sensor with 16-bit ADCs and signal conditioning
- Digital Motion Processor (DMP) engine
- Primary I²C and SPI (MPU-6000 only) serial communications interfaces
- Auxiliary I²C serial interface for 3rd party magnetometer & other sensors
- Clocking
- Sensor Data Registers
- FIFO
- Interrupts
- Digital-Output Temperature Sensor
- Self-test
- Bias and LDO
- Charge Pump

7.7 Three-Axis MEMS Gyroscope with 16-bit ADCs and Signal Conditioning

The MPU-60X0 consists of three independent vibratory MEMS rate gyroscopes, which detect rotation about the X, Y, and Z axes. When the gyros are rotated about any of the sense axes, the Coriolis Effect causes a vibration that is detected by a capacitive pickoff. The resulting signal is amplified, demodulated, and filtered to produce a voltage that is proportional to the angular rate. This voltage is digitized using individual on-chip 16-bit Analog-to-Digital Converters (ADCs) to sample each axis. The full-scale range of the gyro sensors may be digitally programmed to ± 250 , ± 500 , ± 1000 , or ± 2000 degrees per second (dps). The ADC sample rate is programmable from 8,000 samples per second, down to 3.9 samples per second, and user-selectable low-pass filters enable a wide range of cut-off frequencies.

7.8 Three-Axis MEMS Accelerometer with 16-bit ADCs and Signal Conditioning

The tri-axis accelerometer uses separate proof masses for each axis. Acceleration along a particular axis induces displacement on the respective proof mass, and capacitive sensors detect the displacement differentially. The architecture reduces the susceptibility to fabrication variations as well as to thermal drift. When the device sits on a flat surface, it will measure 0g on the X- and Y-axes and +1g on the Z-axis. Accelerometer scale factor is calibrated at the factory and is nominally independent of supply voltage. Each sensor has a dedicated sigma-delta ADC for providing digital outputs. The full scale range of the digital output can be adjusted to $\pm 2g$, $\pm 4g$, $\pm 8g$, or $\pm 16g$.

7.9 Digital Motion Processor

The embedded Digital Motion Processor (DMP) is located within the MPU-60X0 and offloads computation of motion processing algorithms from the host processor. The DMP acquires data from accelerometers, gyroscopes, and additional sensors such as magnetometers, and processes the data. The resulting data can be read from the DMP's registers, or can be buffered in a FIFO. The DMP has access to one of the MPU's external pins, which can be used for generating interrupts.

The purpose of the DMP is to offload both timing requirements and processing power from the host processor. Typically, motion processing algorithms should be run at a high rate, often around 200Hz, in order to provide accurate results with low latency. This is required even if the application updates at a much lower rate; for example, a low power user interface may update as slowly as 5Hz, but the motion processing should still run at 200Hz. The DMP can be used as a tool in order to minimize power, simplify timing and the software architecture, and save valuable MIPS on the host processor for use in the application.

7.10 Primary I²C and SPI Serial Communications Interfaces

The MPU-60X0 communicates to a system processor using either SPI (MPU-6000 only) or I²C serial interfaces, and the device always acts as a slave when communicating to the system processor. The logic level for communications to the master is set by the voltage on the VLOGIC pin – (MPU-6050) or by VDD (MPU-6000). The LSB of the of the I²C slave address is set by pin 9 (AD0).

7.11 Auxiliary I²C Serial Interface

The MPU-60X0 has an auxiliary I²C bus for communicating to an off-chip 3-axis digital output magnetometer or other sensors. This bus has two operating modes: I²C Master Mode, where the MPU-60X0 acts as a master to an external sensor(s) connected to the auxiliary I²C bus; and Pass-Through Mode, where the MPU-60X0 directly connects the primary and auxiliary I²C buses together, to allow the system processor to directly communicate with the external sensor(s).

Auxiliary I²C Bus Modes of Operation:

- **I²C Master Mode:** allows the MPU-60X0 to directly access the data registers of external digital sensors, such as a magnetometer. In this mode, the MPU-60X0 directly obtains data from auxiliary sensors, allowing the on-chip DMP to generate sensor fusion data without intervention from the system applications processor.

For example, In I²C master mode, the MPU-60X0 can be configured to perform burst reads, returning the following data from a magnetometer:

- X magnetometer data (2 bytes)
- Y magnetometer data (2 bytes)
- Z magnetometer data (2 bytes)

The I²C master can be configured to read up to 24 bytes from up to 5 auxiliary sensors.

- **Pass-Through Mode:** allows an external system processor to act as master and directly communicate to the external sensor connected to the auxiliary I²C bus pins (AUX_DA and AUX_CL). This is useful for configuring the external sensor, or for keeping the MPU-60X0 in a low-power mode, when only the external sensor is to be used. In this mode, the auxiliary I²C bus control logic (third-party sensor interface block) of the MPU-60X0 is disabled, and the auxiliary I²C pins AUX_DA and AUX_CL (Pins 6 and 7) are connected to the main I²C bus (Pins 23 and 24) through analog switches.

Auxiliary I²C Bus IO Logic Levels

The logic level of the auxiliary I²C bus can be programmed to be either VDD or VLOGIC (VLOGIC on MPU-6050 only). See Section 10.2 for a detailed description of this feature.

7.12 Self-Test

Self-test allows for the testing of the mechanical and electrical portions of the sensors. The self-test for each measurement axis can be activated by controlling the bits of the GYRO_CONFIG and ACCEL_CONFIG control registers. When self-test is activated, the electronics cause the sensors to be actuated and produce an output signal. The sensor reading is determined by the sum of the sensor output and the self-test response. The self-test response for each accelerometer axis is defined in the specification table to be nominally 0.5g. Similarly, for the gyro axes, self test allows the proof masses to be moved equivalent to a pre-defined Coriolis force, resulting in a change in sensor output. The self-test response for each gyroscope axis is defined in the specification table to be nominally 50°/s.

7.13 MPU-60X0 Solution for 9-axis Sensor Fusion Using I²C Interface

In the figure below, the system processor is an I²C master to the MPU-60X0. In addition, the MPU-60X0 is an I²C master to the optional external compass sensor. The MPU-6000 has limited capabilities as an I²C Master, and depends on the system processor to manage the initial configuration of any auxiliary sensors. The MPU-6000 has an interface bypass multiplexer, which connects the system processor I²C bus pins 23 and 24 (SDA and SCL) directly to the auxiliary sensor I²C bus pins 6 and 7 (AUX_DA and AUX_CL).

Once the auxiliary sensors have been configured by the system processor, the interface bypass multiplexer should be disabled so the MPU-6000 auxiliary I²C master can take control of the sensor I²C bus and gather data from the auxiliary sensors.

I²C master control is discussed in more detail in Section 13 (Register Descriptions).

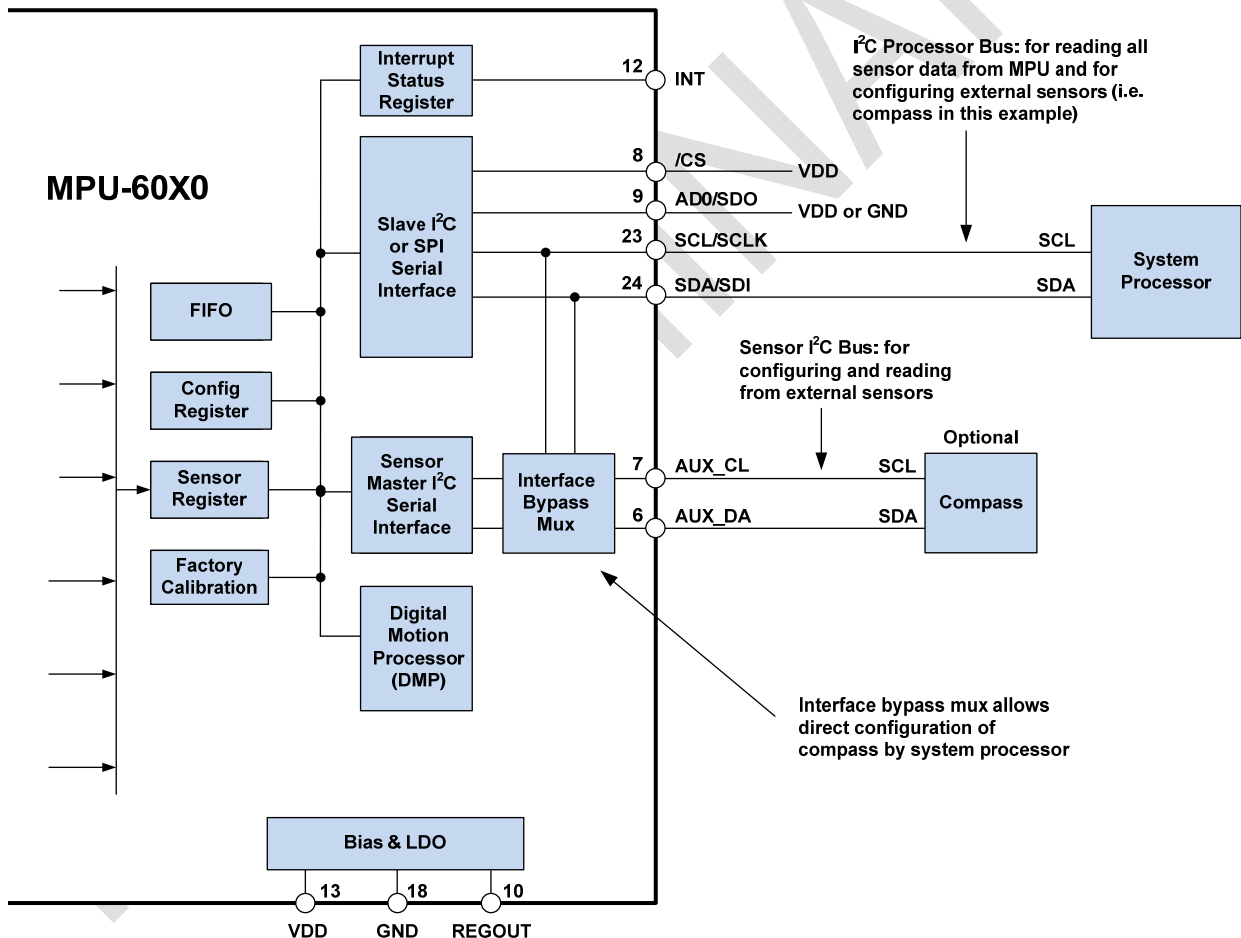

7.14 MPU-6000 Using SPI Interface

In the figure below, the system processor is an SPI master to the MPU-6000. Pins 8, 9, 23, and 24 are used to support the /CS, SDO, SCLK, and SDI signals for SPI communications. Because these SPI pins are shared with the I²C slave pins (9, 23 and 24), the system processor cannot access the auxiliary I²C bus through the interface bypass multiplexer, which connects the processor I²C interface pins to the sensor I²C interface pins.

Since the MPU-6000 has limited capabilities as an I²C Master, and depends on the system processor to manage the initial configuration of any auxiliary sensors, another method must be used for programming the sensors on the auxiliary sensor I²C bus pins 6 and 7 (AUX_DA and AUX_CL).

When using SPI communications between the MPU-6000 and the system processor, configuration of devices on the I²C sensor bus can be achieved by performing single byte read and write transactions on any device and register on the auxiliary I²C bus by using I2C Slave 4 Control (see Registers 49 to 53). Once the external sensors are configured, the MPU-6000 has the capability to perform single or multi-byte reads using the sensor I²C bus. The Slave 0 to Slave 3 controllers may have the read result written to the FIFO buffer as well as to the sensor registers.

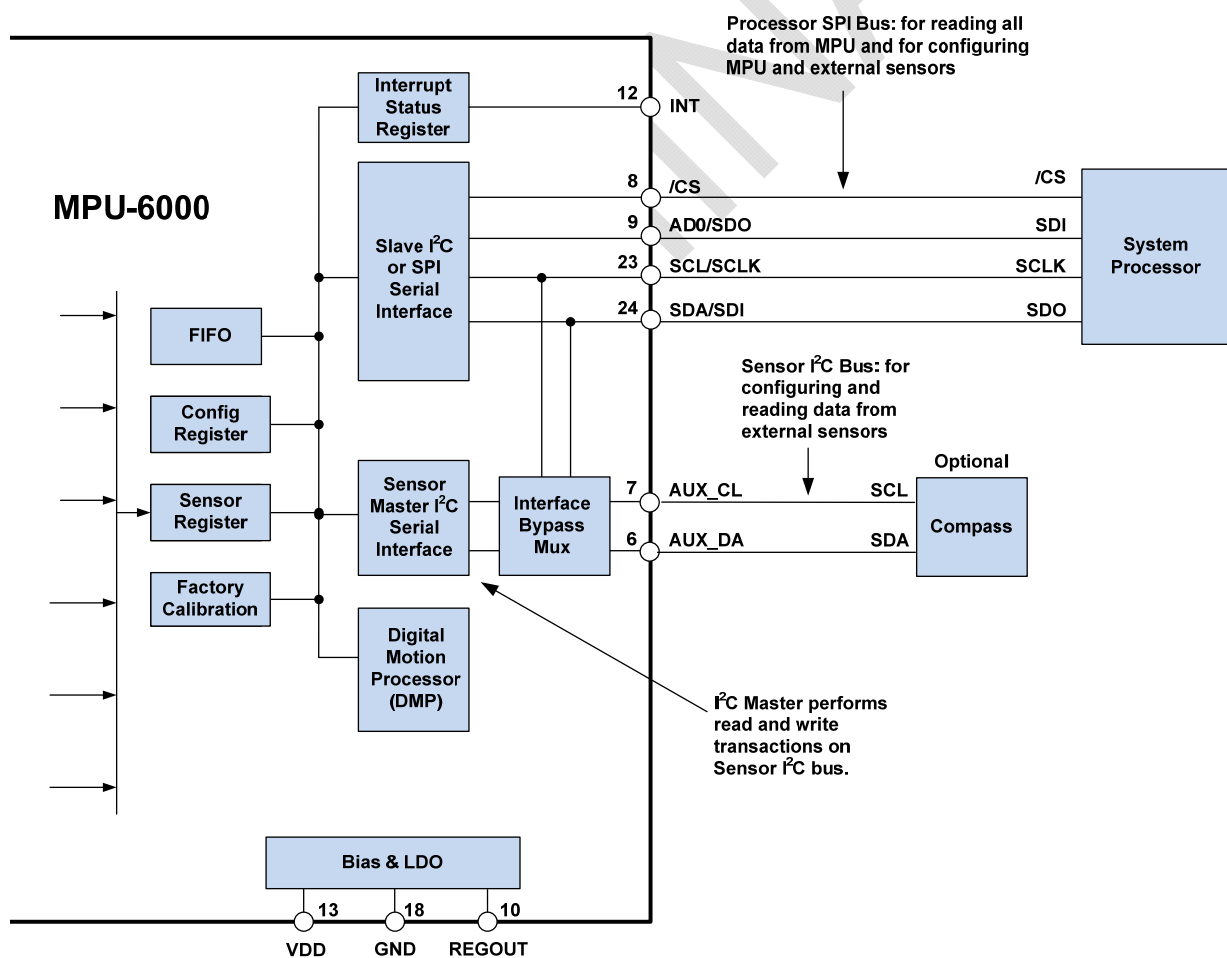

8 Programmable Interrupts

The MPU-60X0 has a programmable interrupt system which can generate an interrupt signal on the INT pin. Status flags indicate the source of an interrupt. Interrupt sources may be enabled and disabled individually.

Table of Interrupt Sources

Interrupt Name	Module
Free Fall Detection	Free Fall
Motion Detection	Motion
Zero Motion Detection	Zero Motion
FIFO Overflow	FIFO
PLL Ready	PLL
DMP Interrupt	DMP
Data Ready	Sensor Registers
I ² C Master errors: Lost Arbitration, NACKs	I ² C Master
I ² C Slave 4	I ² C Master

Interrupts are described in the register description (Section 13) which provides more information about their enable/disable register and flag register. Some interrupt sources are explained in detail below.

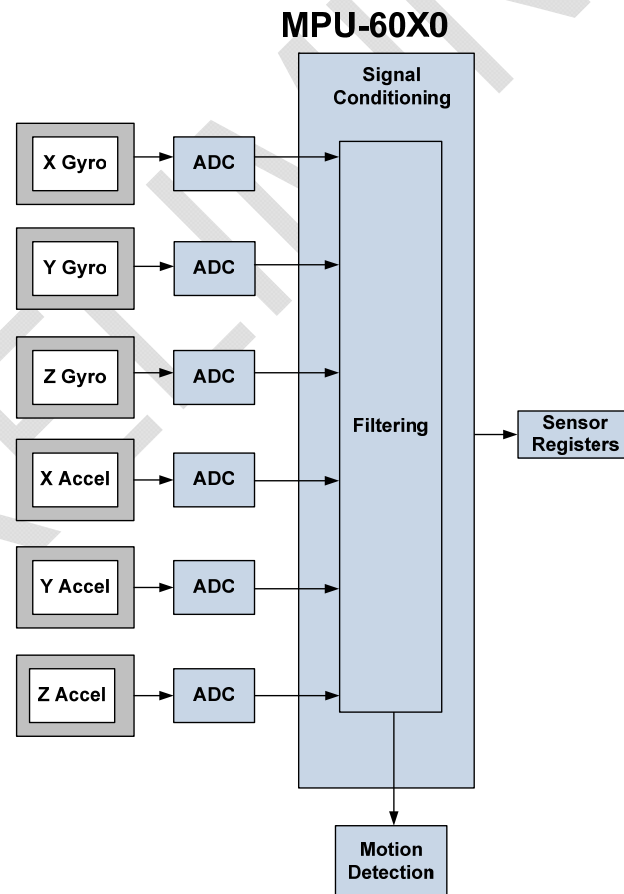

8.1 Free Fall, Motion, and Zero Motion Signal Paths

The diagram below shows the signal path for the gyroscope and accelerometer sensors. Note that each digital low pass filter (DLPF) is configured identically, as is each sample rate divider and digital high pass filter (DHPF).

8.2 Free Fall Interrupt

Free fall is detected by checking if the accelerometer measurement from all three axes has an absolute value below a user-programmable threshold (acceleration threshold). For each sample where this condition is true (a qualifying sample), a counter is incremented. For each sample where this condition is false (a non-qualifying sample), the counter is decremented. Once the counter reaches a user-programmable threshold (the counter threshold), the Free Fall interrupt is triggered, and a flag is set. The flag is cleared once the counter has decremented to zero. The counter does not increment above the counter threshold or decrement below zero.

The user is given several configuration parameters to fine tune Free Fall detection. Both, the acceleration threshold and counter threshold, are user configurable. The FF_THR register allows the user to set a threshold in steps of 1mg. The FF_DUR register allows the user to set duration in steps of 1 ms.

The decrement rate for non-qualifying samples may also be configured. The MOT_DETECT_CTRL register allows the user to specify whether a non-qualifying sample makes the counter reset to zero, or decrement in steps of 1, 2, or 4.

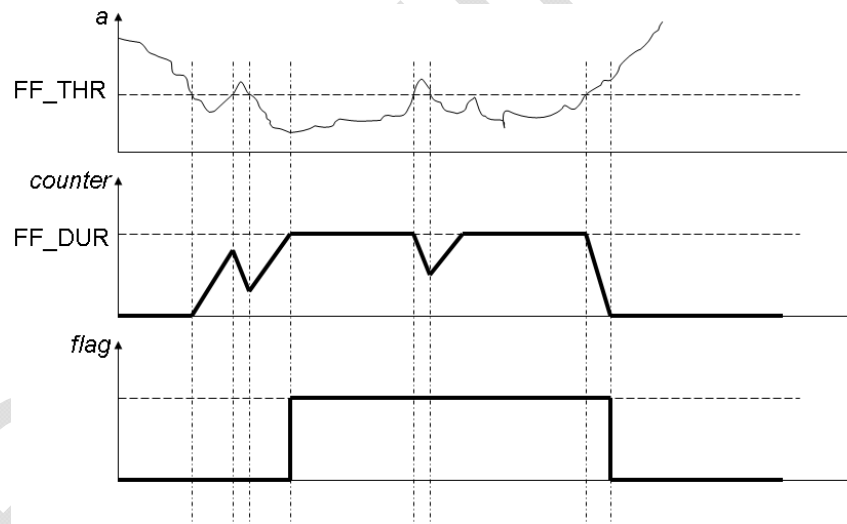

The plots in the figure above show an example acceleration input signal (simplified to only show one axis), qualifying sample counter, and Free Fall flag.

8.3 Motion Interrupt

The MPU-60X0 provides Motion detection capability that works in a similar manner to Free Fall detection. Accelerometer measurements are passed through a configurable digital high pass filter (DHPF) in order to eliminate bias due to gravity. A qualifying motion sample is one where the high passed sample from any axis has an absolute value exceeding a user-programmable threshold. A counter increments for each qualifying sample, and decrements for each non-qualifying sample. Once the counter reaches a user-programmable

counter threshold, a motion interrupt is triggered. The axis and polarity which caused the interrupt to be triggered is flagged in the MOT_DETECT_STATUS register.

Like with Free Fall detection, Motion detection has a configurable acceleration threshold MOT_THR specified in steps of 1 mg. The counter threshold MOT_DUR is specified in steps of 1 ms. The decrement rate has the same options as Free Fall detection, and is specified in the MOT_DETECT_CTRL register.

8.4 Zero Motion Interrupt

Zero Motion detection capability uses the digital high pass filter (DHPF) and a similar threshold scheme to Free Fall detection. Each axis of the high passed accelerometer measurement must have an absolute value less than a threshold specified in the ZRMOT_THR register. This increments a counter, which generates an interrupt when reaching the threshold specified in ZRMOT_DUR.

Unlike Free Fall or Motion detection, Zero Motion detection triggers an interrupt both when Zero Motion is first detected and when Zero Motion is no longer detected. While Free Fall and Motion are indicated with a flag which clears after being read, reading the state of the Zero Motion detected from the MOT_DETECT_STATUS register does not clear its status.

PRELIMINARY

9 Clocking

9.1 Internal Clock Generation

The MPU-60X0 has a flexible clocking scheme, allowing for a variety of internal or external clock sources for the internal synchronous circuitry. This synchronous circuitry includes the signal conditioning and ADCs, the DMP, and various control circuits and registers. An on-chip PLL provides flexibility in the allowable inputs for generating this clock.

Allowable internal sources for generating the internal clock are:

- An internal relaxation oscillator
- Any of the X, Y, or Z gyros (MEMS oscillators with a variation of $\pm 1\%$ over temperature)

Allowable external clocking sources are:

- 32.768kHz square wave
- 19.2MHz square wave

Selection of source for generating the internal synchronous clock depends on the availability of external sources and the requirements for power consumption and clock accuracy. Most likely, these requirements will vary by mode of operation. For example, in one mode, where the biggest concern is power consumption, one may wish to operate the Digital Motion Processor of the MPU-60X0 to process accelerometer data, while keeping the gyros off. In this case, the internal relaxation oscillator is a good clock choice. However, in another mode, where the gyros are active, selecting the gyros as the clock source provides for a more accurate clock source.

Clock accuracy is important, since timing errors directly affect the distance and angle calculations performed by the Digital Motion Processor (or by extension, by any processor).

There are also start-up conditions to consider. When the MPU-60X0 first starts up, the device uses its internal clock until programmed to operate from another source. This allows the user, for example, to wait for the MEMS oscillators to stabilize before they are selected as the clock source.

9.2 Sensor Data Registers

The sensor data registers contain the latest gyro, accelerometer, auxiliary sensor, and temperature data. They are read-only registers, and are accessed via the serial interface. Data from these registers may be read anytime, however, the interrupt function may be used to determine when new data is available.

9.3 FIFO

The MPU-60X0 contains a 1024-byte FIFO register that is accessible via the Serial Interface. The FIFO configuration register determines what data goes into it, with possible choices being gyro data, accelerometer data, temperature readings, auxiliary sensor readings, and FSYNC input. A FIFO counter keeps track of how many bytes of valid data are contained in the FIFO. The FIFO register supports burst reads. The interrupt function may be used to determine when new data is available.

9.4 Interrupts

Interrupt functionality is configured via the Interrupt Configuration register. Items that are configurable include the INT pin configuration, the interrupt latching and clearing method, and triggers for the interrupt. Items that can trigger an interrupt are (1) Clock generator locked to new reference oscillator (used when switching clock sources); (2) Digital Motion Processor Done (programmable function); (3) new data is available to be read (from the FIFO and Data registers); (4) accelerometer event interrupts; and (5) the MPU-60X0 did not

receive an acknowledge from an auxiliary sensor on the secondary I²C bus. The interrupt status can be read from the Interrupt Status register.

9.5 Digital-Output Temperature Sensor

An on-chip temperature sensor and ADC are used to measure the MPU-60X0 die temperature. The readings from the ADC can be read from the FIFO or the Sensor Data registers.

9.6 Bias and LDO

The bias and LDO section generates the internal supply and the reference voltages and currents required by the MPU-60X0. Its two inputs are an unregulated VDD of 2.1V to 3.6V and a VLOGIC logic reference supply voltage of 1.71V to VDD (MPU-6050 only). The LDO output is bypassed by a capacitor at REGOUT. For further details on the capacitor, please refer to the [Bill of Materials for External Components](#) section.

9.7 Charge Pump

An on-board charge pump generates the high voltage required for the MEMS oscillators. Its output is bypassed by a capacitor at CPOUT. For further details on the capacitor, please refer to the [Bill of Materials for External Components](#) section.

10 Digital Interface

10.1 I²C and SPI (MPU-6000 only) Serial Interfaces

The internal registers and memory of the MPU-6000/MPU-6050 can be accessed using either I²C at 400 kHz or SPI at 1MHz (MPU-6000 only). SPI operates in four-wire mode.

Serial Interface

Pin Number	MPU-6000	MPU-6050	Pin Name	Pin Description
8	Y		/CS	SPI chip select (0=SPI enable)
8		Y	VLOGIC	Digital I/O supply voltage. VLOGIC must be ≤ VDD at all times.
9	Y		AD0 / SDO	I ² C Slave Address LSB (AD0); SPI serial data output (SDO)
9		Y	AD0	I ² C Slave Address LSB
23	Y		SCL / SCLK	I ² C serial clock (SCL); SPI serial clock (SCLK)
23		Y	SCL	I ² C serial clock
24	Y		SDA / SDI	I ² C serial data (SDA); SPI serial data input (SDI)
24		Y	SDA	I ² C serial data

Note:

To prevent switching into I²C mode when using SPI (MPU-6000), the I²C interface should be disabled by setting the *I2C_IF_DIS* configuration bit. Setting this bit should be performed immediately after waiting the time specified by the “Start-Up Time for Register Read/Write” in Section 3.2.

10.2 I²C Interface

I²C is a two-wire interface comprised of the signals serial data (SDA) and serial clock (SCL). In general, the lines are open-drain and bi-directional. In a generalized I²C interface implementation, attached devices can be a master or a slave. The master device puts the slave address on the bus, and the slave device with the matching address acknowledges the master.

The MPU-60X0 always operates as a slave device when communicating to the system processor, which thus acts as the master. SDA and SCL lines typically need pull-up resistors to VDD. The maximum bus speed is 400 kHz.

The slave address of the MPU-60X0 is b110100X which is 7 bits long. The LSB bit of the 7 bit address is determined by the logic level on pin AD0. This allows two MPU-60X0s to be connected to the same I²C bus. When used in this configuration, the address of the one of the devices should be b1101000 (pin AD0 is logic low) and the address of the other should be b1101001 (pin AD0 is logic high).

10.3 I²C Communications Protocol

START (S) and STOP (P) Conditions

Communication on the I²C bus starts when the master puts the START condition (S) on the bus, which is defined as a HIGH-to-LOW transition of the SDA line while SCL line is HIGH (see figure below). The bus is considered to be busy until the master puts a STOP condition (P) on the bus, which is defined as a LOW to HIGH transition on the SDA line while SCL is HIGH (see figure below).

Additionally, the bus remains busy if a repeated START (Sr) is generated instead of a STOP condition.

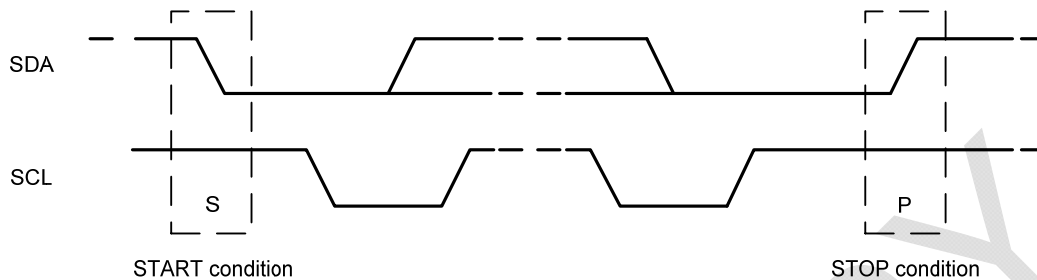

START and STOP Conditions

Data Format / Acknowledge

I²C data bytes are defined to be 8-bits long. There is no restriction to the number of bytes transmitted per data transfer. Each byte transferred must be followed by an acknowledge (ACK) signal. The clock for the acknowledge signal is generated by the master, while the receiver generates the actual acknowledge signal by pulling down SDA and holding it low during the HIGH portion of the acknowledge clock pulse.

If a slave is busy and cannot transmit or receive another byte of data until some other task has been performed, it can hold SCL LOW, thus forcing the master into a wait state. Normal data transfer resumes when the slave is ready, and releases the clock line (refer to the following figure).

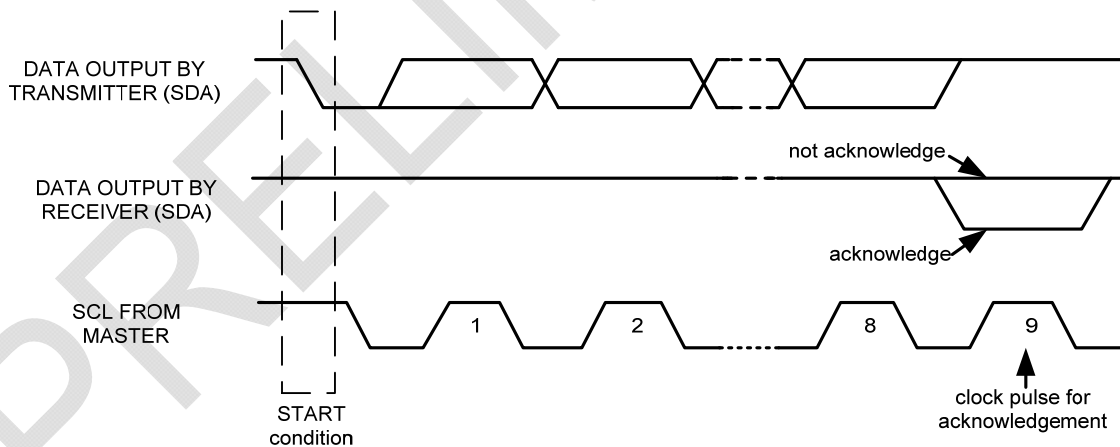

Acknowledge on the I²C Bus

Communications

After beginning communications with the START condition (S), the master sends a 7-bit slave address followed by an 8th bit, the read/write bit. The read/write bit indicates whether the master is receiving data from or is writing to the slave device. Then, the master releases the SDA line and waits for the acknowledge signal (ACK) from the slave device. Each byte transferred must be followed by an acknowledge bit. To acknowledge, the slave device pulls the SDA line LOW and keeps it LOW for the high period of the SCL line. Data transmission is always terminated by the master with a STOP condition (P), thus freeing the communications line. However, the master can generate a repeated START condition (Sr), and address another slave without first generating a STOP condition (P). A LOW to HIGH transition on the SDA line while SCL is HIGH defines the stop condition. All SDA changes should take place when SCL is low, with the exception of start and stop conditions.

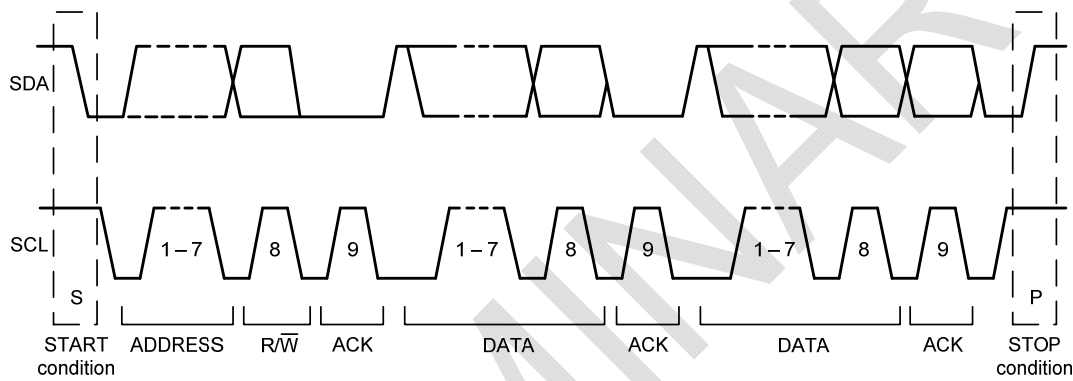

Complete I²C Data Transfer

To write the internal MPU-60X0 registers, the master transmits the start condition (S), followed by the I²C address and the write bit (0). At the 9th clock cycle (when the clock is high), the MPU-60X0 acknowledges the transfer. Then the master puts the register address (RA) on the bus. After the MPU-60X0 acknowledges the reception of the register address, the master puts the register data onto the bus. This is followed by the ACK signal, and data transfer may be concluded by the stop condition (P). To write multiple bytes after the last ACK signal, the master can continue outputting data rather than transmitting a stop signal. In this case, the MPU-60X0 automatically increments the register address and loads the data to the appropriate register. The following figures show single and two-byte write sequences.

Single-Byte Write Sequence

Master	S	AD+W		RA		DATA		P
Slave			ACK		ACK		ACK	

Burst Write Sequence

Master	S	AD+W		RA		DATA		DATA		P
Slave			ACK		ACK		ACK		ACK	

To read the internal MPU-60X0 registers, the master sends a start condition, followed by the I²C address and a write bit, and then the register address that is going to be read. Upon receiving the ACK signal from the MPU-60X0, the master transmits a start signal followed by the slave address and read bit. As a result, the MPU-60X0 sends an ACK signal and the data. The communication ends with a not acknowledge (NACK) signal and a stop bit from master. The NACK condition is defined such that the SDA line remains high at the 9th clock cycle. The following figures show single and two-byte read sequences.

Single-Byte Read Sequence

Master	S	AD+W		RA		S	AD+R			NACK	P
Slave			ACK		ACK			ACK	DATA		

Burst Read Sequence

Master	S	AD+W		RA		S	AD+R			ACK		NACK	P
Slave			ACK		ACK			ACK	DATA		DATA		

10.4 I²C Terms

Signal	Description
S	Start Condition: SDA goes from high to low while SCL is high
AD	Slave I ² C address
W	Write bit (0)
R	Read bit (1)
ACK	Acknowledge: SDA line is low while the SCL line is high at the 9 th clock cycle
NACK	Not-Acknowledge: SDA line stays high at the 9 th clock cycle
RA	MPU-60X0 internal register address
DATA	Transmit or received data
P	Stop condition: SDA going from low to high while SCL is high

10.5 SPI Interface (MPU-6000 only)

SPI is a 4-wire synchronous serial interface that uses two control and two data lines. The MPU-6000 always operates as a Slave device during standard Master-Slave SPI operation. With respect to the Master, the Serial Clock output (SCLK), the Data Output (SDO) and the Data Input (SDI) are shared among the Slave devices. The Master generates an independent Chip Select (/CS) for each Slave device; /CS goes low at the start of transmission and goes back high at the end. The Serial Data Output (SDO) line remains in a high-impedance (high-z) state when the device is not selected so it does not interfere with any active devices.

SPI Operational Features

1. Data is delivered MSB first and LSB last
2. Data is latched on rising edge of SCLK
3. Data should be transitioned on the falling edge of SCLK
4. SCLK frequency is 1MHz max
5. SPI read and write operations are completed in 16 or more clock cycles (two or more bytes). The first byte contains the SPI Address, and the following byte(s) contain(s) the SPI data. The first bit of the first byte contains the Read/Write bit and indicates the Read (1) or Write (0) operation. The following 7 bits contain the Register Address. In cases of multiple-byte Read/Writes, data is two or more bytes:

SPI Address format

MSB							LSB
R/W	A6	A5	A4	A3	A2	A1	A0

SPI Data format

MSB							LSB
D7	D6	D5	D4	D3	D2	D1	D0

6. Supports Single or Burst Read/Writes.

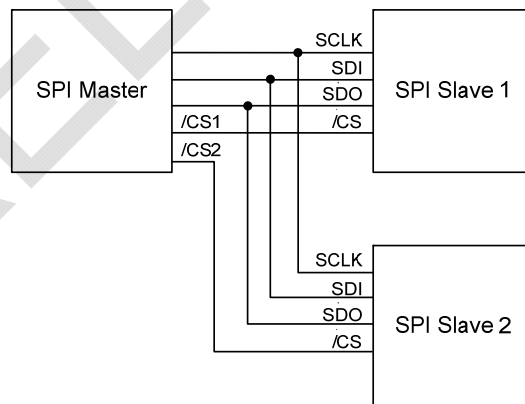

Typical SPI Master / Slave Configuration

Each SPI slave requires its own Chip Select (/CS) line. SDO, SDI and SCLK lines are shared. Only one /CS line is active (low) at a time ensuring that only one slave is selected at a time. The /CS lines of other slaves are held high which causes their respective SDO pins to be high-Z.

11 Serial Interface Considerations (MPU-6050)

11.1 MPU-6050 Supported Interfaces

The MPU-6050 supports I²C communications on both its primary (microprocessor) serial interface and its auxiliary interface.

11.2 Logic Levels

The MPU-6050 I/O logic levels are set to be either VDD or VLOGIC, as shown in the table below.

I/O Logic Levels vs. *AUX_VDDIO*

<i>AUX_VDDIO</i>	MICROPROCESSOR LOGIC LEVELS (Pins: SDA, SCL, AD0, CLKIN, INT)	AUXILLARY LOGIC LEVELS (Pins: AUX_DA, AUX_CL)
0	VLOGIC	VLOGIC
1	VLOGIC	VDD

Note: The power-on-reset value for *AUX_VDDIO* is 0.

VLOGIC may be set to be equal to VDD or to another voltage, such that at all times VLOGIC is \leq VDD. When *AUX_VDDIO* is set to 0 (its power-on-reset value), VLOGIC is the power supply voltage for both the microprocessor system bus and the auxiliary I²C bus, as shown in the figure of Section 10.2.1. When *AUX_VDDIO* is set to 1, VLOGIC is the power supply voltage for the microprocessor system bus and VDD is the supply for the auxiliary I²C bus, as shown in the figure of Section 10.2.2.

11.3 Logic Levels Diagram for $AUX_VDDIO = 0$

The figure below depicts a sample circuit with a third party magnetometer attached to the auxiliary I²C bus. It shows logic levels and voltage connections for $AUX_VDDIO = 0$. Note: Actual configuration will depend on the auxiliary sensors used.

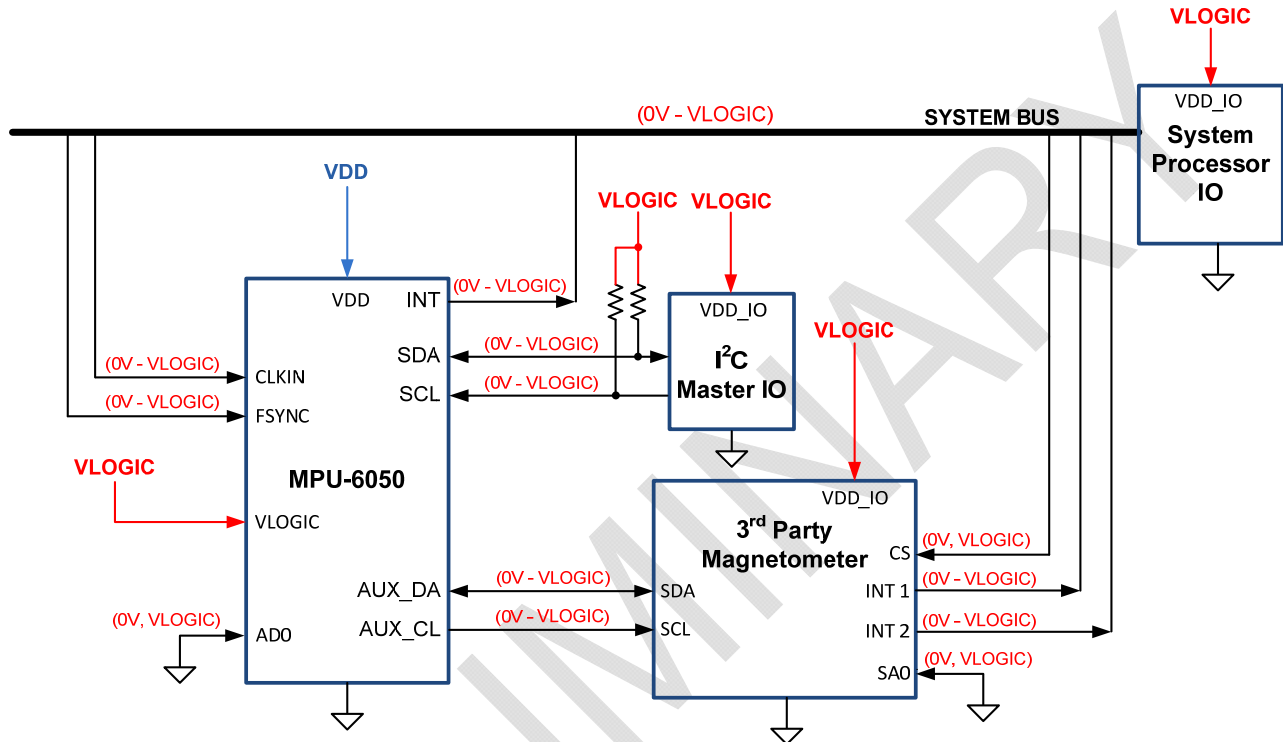

I/O Levels and Connections for $AUX_VDDIO = 0$

Notes:

1. AUX_VDDIO determines the IO voltage levels of AUX_DA and AUX_CL (0 = set output levels relative to VLOGIC)
2. Other MPU-6050 logic IO is always referenced to VLOGIC.

11.4 Logic Levels Diagram for $AUX_VDDIO = 1$

The figure below depicts a sample circuit with a third party magnetometer attached to the auxiliary I²C bus. It shows logic levels and voltage connections for $AUX_VDDIO = 1$. This configuration is useful when the auxiliary sensor has only one supply for logic and power. Note: Actual configuration will depend on the auxiliary sensors used.

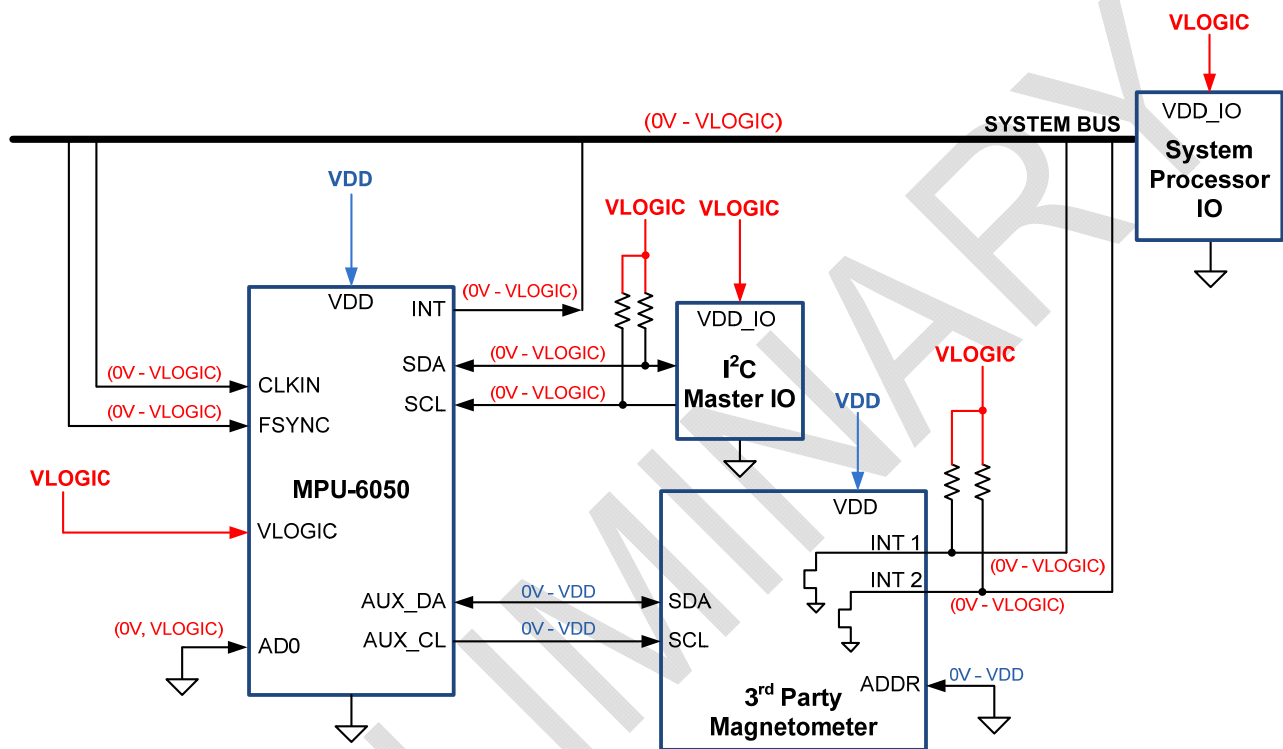

Voltage/Configuration	Configuration 1	Configuration 2
VLOGIC	1.8V±5%	3.0V±5%
VDD	2.5V±5%	3.0V±5%
AUX_VDDIO	1	1

I/O Levels and Connections for Two Example Power Configurations ($AUX_VDDIO = 1$)
Notes:

1. AUX_VDDIO determines the IO voltage levels of AUX_DA and AUX_CL . $AUX_VDDIO = 1$ sets output levels relative to VDD.
2. Other MPU-6050 logic IO is always referenced to VLOGIC.
3. Third-party auxiliary device logic levels are referenced to VDD. Setting INT1 and INT2 to open drain configuration provides voltage compatibility when $VDD \neq VLOGIC$. When $VDD = VLOGIC$, INT1 and INT2 may be set to push-pull outputs, and external pull-up resistors are not needed.

12 Assembly

This section provides general guidelines for assembling InvenSense Micro Electro-Mechanical Systems (MEMS) gyros packaged in Quad Flat No leads package (QFN) surface mount integrated circuits.

12.1 Orientation of Axes

The diagram below shows the orientation of the axes of sensitivity and the polarity of rotation. Note the pin 1 identifier in the figure.

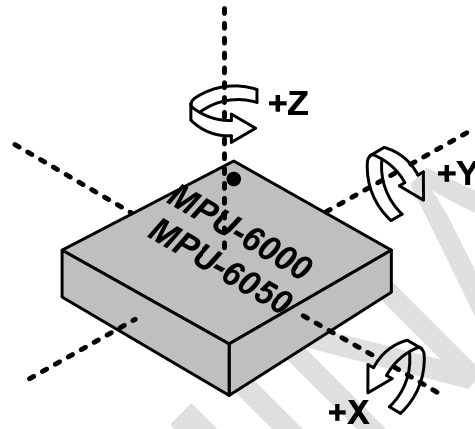

**Orientation of Axes of Sensitivity
and Polarity of Rotation**

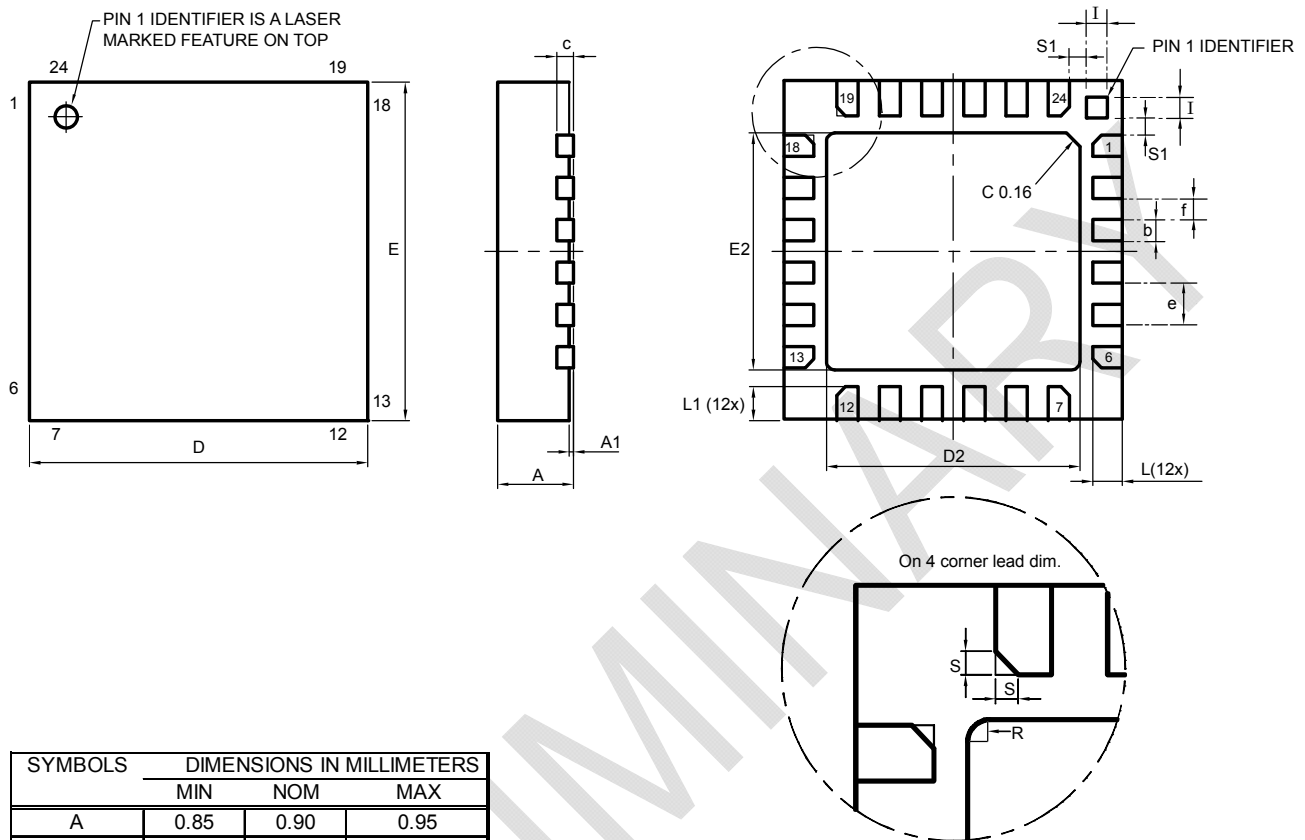
12.2 Package Dimensions

SYMBOLS	DIMENSIONS IN MILLIMETERS		
	MIN	NOM	MAX
A	0.85	0.90	0.95
A1	0.00	0.02	0.05
b	0.18	0.25	0.30
c	---	0.20 REF.	---
D	3.90	4.00	4.10
D2	2.95	3.00	3.05
E	3.90	4.00	4.10
E2	2.75	2.80	2.85
e	---	0.50	---
f (e-b)	0.20	0.25	0.32
L	0.30	0.35	0.40
L1	0.35	0.40	0.45
l	0.20	0.25	0.30
R	0.05	---	0.10
s	0.05	---	0.15
S1	0.15	0.20	0.25

12.3 PCB Design Guidelines:

The Pad Diagram is shown below using a JEDEC type extension with solder rising on the outer edge. The Pad Dimensions Table shows pad sizing (mean dimensions) recommended for the MPU-60X0 product.

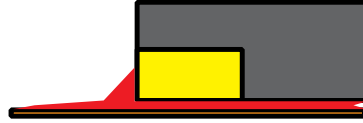

JEDEC type extension with solder rising on outer edge

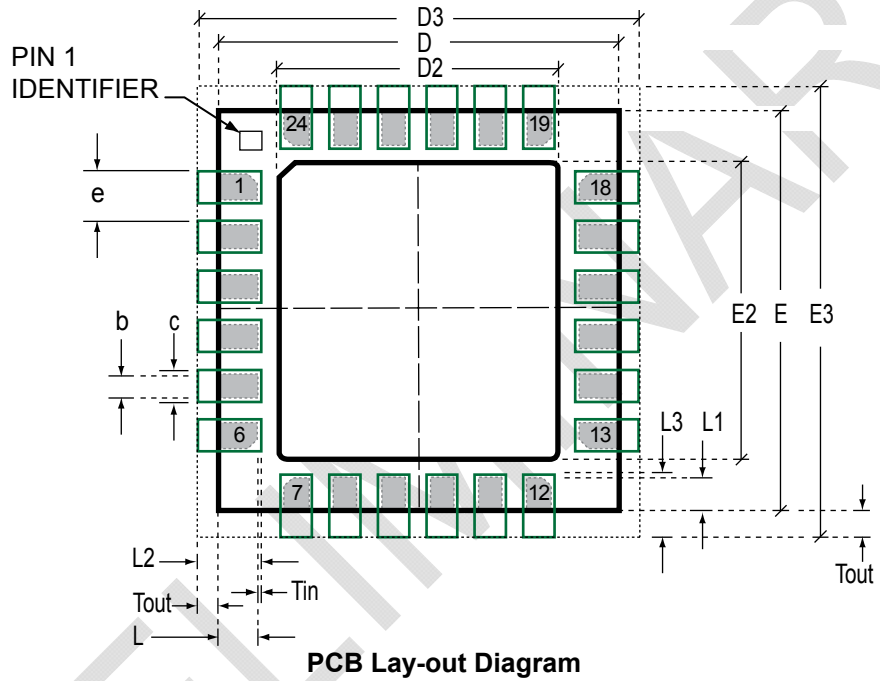

SYMBOLS	DIMENSIONS IN MILLIMETERS	NOM
Nominal Package I/O Pad Dimensions		
e	Pad Pitch	0.50
b	Pad Width	0.25
L	Pad Length	0.35
L1	Pad Length	0.40
D	Package Width	4.00
E	Package Length	4.00
D2	Exposed Pad Width	3.00
E2	Exposed Pad Length	2.80
I/O Land Design Dimensions (Guidelines)		
D3	I/O Pad Extent Width	4.80
E3	I/O Pad Extent Length	4.80
c	Land Width	0.35
Tout	Outward Extension	0.40
Tin	Inward Extension	0.05
L2	Land Length	0.80
L3	Land Length	0.85

PCB Dimensions Table (for PCB Lay-out Diagram)

12.4 Assembly Precautions

12.4.1 Gyroscope Surface Mount Guidelines

InvenSense MEMS Gyros sense rate of rotation. In addition, gyroscopes sense mechanical stress coming from the PCB. This PCB stress is minimized with simple design rules:

When using MEMS gyroscope components in plastic packages, package stress due to PCB mounting and assembly could affect the output offset and its value over a wide range of temperatures. This is caused by the mismatch between the Coefficient of Linear Thermal Expansion (CTE) of the package material and the PCB. Care must be taken to avoid package stress due to mounting.

Traces connected to pads should be as much symmetric as possible. Symmetry and balance for pad connection will help component self alignment and will lead to better control of solder paste reduction after reflow.

Any material used in the surface mount assembly process of the MEMS gyroscope should be free of restricted RoHS elements or compounds. Pb-free solders should be used for assembly.

12.4.2 Exposed Die Pad Precautions

The MPU-60X0 has very low active and standby current consumption. The exposed die pad is not required for heat sinking, and should not be soldered to the PCB since soldering to it contributes to performance

changes due to package thermo-mechanical stress. There is no electrical connection between the pad and the CMOS.

12.4.3 Trace Routing

Testing indicates that 3-Volt peak-to-peak signals run under the gyro package or directly on top of the package of frequencies from DC to 1MHz do not affect the operation of the MEMS gyro. However, routing traces or vias under the MEMS gyro package, such that they run under the exposed die pad, is prohibited.

12.4.4 Component Placement

Do not place large insertion components such as keyboard or similar buttons, connectors, or shielding boxes at a distance of less than 6 mm from the MEMS gyro. Maintain generally accepted industry design practices for component placement near the MPU-60X0 to prevent noise coupling and thermo-mechanical stress.

12.4.5 PCB Mounting and Cross-Axis Sensitivity

Orientation errors of the gyroscope mounted to the printed circuit board can cause cross-axis sensitivity in which one gyro responds to rotation about another axis, for example, the X-axis gyroscope responding to rotation about the Y or Z axes. The orientation mounting errors are illustrated in the figure below.

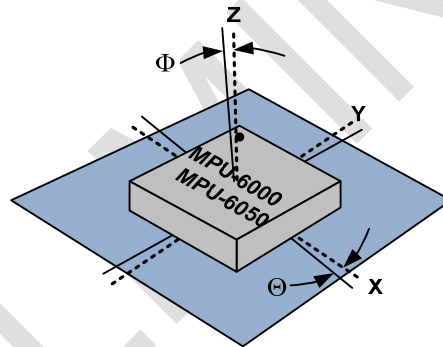

Package Gyro Axes (.....) Relative to PCB Axes (———) with Orientation Errors (θ and Φ)

The table below shows the cross-axis sensitivity as a percentage of the specified gyroscope's sensitivity for a given orientation error.

Cross-Axis Sensitivity vs. Orientation Error

Orientation Error (θ or Φ)	Cross-Axis Sensitivity ($\sin\theta$ or $\sin\Phi$)
0°	0%
0.5°	0.87%
1°	1.75%

The specification for cross-axis sensitivity in Section 3 includes the effect of the die orientation error with respect to the package.

12.4.6 MEMS Handling Instructions

MEMS (Micro Electro-Mechanical Systems) are a time-proven, robust technology used in hundreds of millions of consumer, automotive and industrial products. MEMS devices consist of microscopic moving mechanical structures. They differ from conventional IC products, even though they can be found in similar packages. Therefore, MEMS devices require different handling precautions than conventional ICs prior to mounting onto printed circuit boards (PCBs).

The MPU-60X0 gyroscope has been qualified to a shock tolerance of 10,000g. InvenSense packages its gyroscopes as it deems proper for protection against normal handling and shipping. It recommends the following handling precautions to prevent potential damage.

- Do not drop individually packaged gyroscopes, or trays of gyroscopes onto hard surfaces. Components placed in trays could be subject to *g*-forces in excess of 10,000g if dropped.
- Printed circuit boards that incorporate mounted gyroscopes should not be separated by manually snapping apart. This could also create *g*-forces in excess of 10,000g.

12.4.7 ESD Considerations

Establish and use ESD-safe handling precautions when unpacking and handling ESD-sensitive devices.

- Store ESD sensitive devices in ESD safe containers until ready for use. The Tape-and-Reel moisture-sealed bag is an ESD approved barrier. The best practice is to keep the units in the original moisture sealed bags until ready for assembly.

Restrict all device handling to ESD protected work areas that measure less than 200V static charge. Ensure that all workstations and personnel are properly grounded to prevent ESD.

12.4.8 Reflow Specification

Qualification Reflow: The MPU-60X0 gyroscope was qualified in accordance with IPC/JEDEC J-STD-020D.01. This standard classifies proper packaging, storage and handling to avoid subsequent thermal and mechanical damage during assembly solder reflow attachment. Classification specifies a sequence consisting of a bake cycle, a moisture soak cycle in a temperature humidity oven, followed by three solder reflow cycles and functional testing for qualification. All temperatures refer to the topside of the QFN package, as measured on the package body surface. The peak solder reflow classification temperature requirement is (260 +5/-0°C) for lead-free soldering of components measuring less than 1.6 mm thick.

Production Reflow: Check the recommendations of your solder manufacturer. For optimum results, production solder reflow processes should reduce exposure to high temperatures, and use lower ramp-up and ramp-down rates than those used in the component qualification profile shown for reference below.

Production reflow should never exceed the maximum constraints listed in the table and shown in the figure below that were used for the qualification profile, as these represent the maximum tolerable ratings for the device.

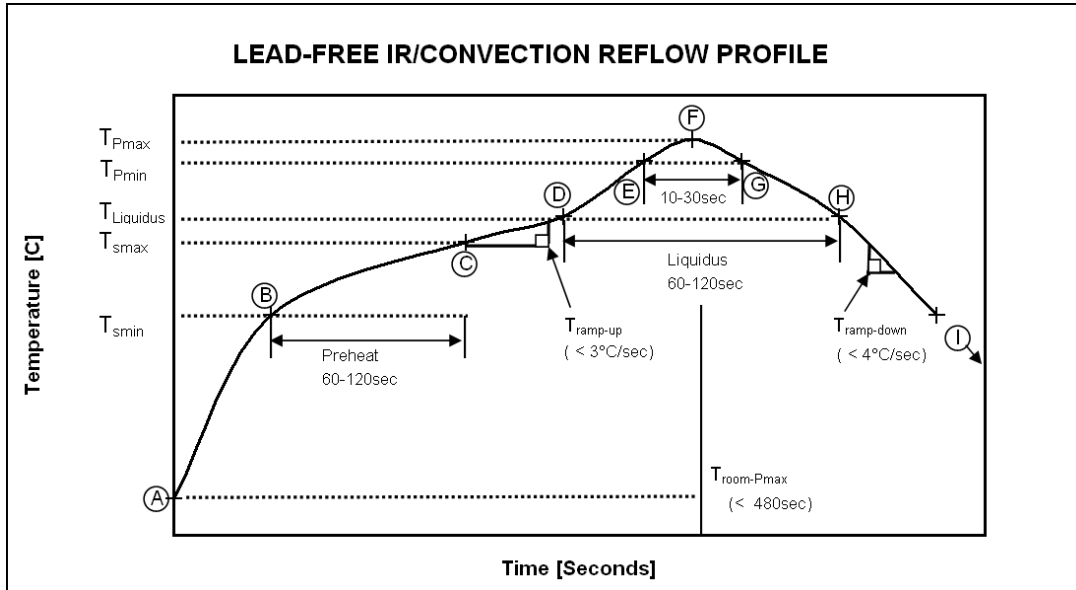
Temperature Set Points for IR / Convection Reflow Corresponding to Figure Above

Step	Setting	CONSTRAINTS		
		Temp (°C)	Time (sec)	Rate (°C/sec)
A	T_{room}	25		
B	T_{Smin}	150		
C	T_{Smax}	200	$60 < t_{\text{BC}} < 120$	
D	T_{Liquidus}	217		$r_{(T_{\text{Liquidus}}-T_{\text{Pmax}})} < 3$
E	T_{Pmin} [255°C, 260°C]	255		$r_{(T_{\text{Liquidus}}-T_{\text{Pmax}})} < 3$
F	T_{Pmax} [260°C, 265°C]	260	$t_{\text{AF}} < 480$	$r_{(T_{\text{Liquidus}}-T_{\text{Pmax}})} < 3$
G	T_{Pmin} [255°C, 260°C]	255	$10 < t_{\text{EG}} < 30$	$r_{(T_{\text{Pmax}}-T_{\text{Liquidus}})} < 4$
H	T_{Liquidus}	217	$60 < t_{\text{DH}} < 120$	
I	T_{room}	25		

Note: T_{Pmax} must not exceed the Classification temperature (260°C).

For suppliers T_{Pmax} must equal or exceed the classification temperature.

12.4.9 Storage Specifications

The storage specification of the MPU-60X0 gyroscope conforms to IPC/JEDEC J-STD-020D.01 Moisture Sensitivity Level (MSL) 3.

Calculated shelf-life in moisture-sealed bag	12 months -- Storage conditions: <40°C and <90% RH
After opening moisture-sealed bag	168 hours -- Storage conditions: ambient ≤30°C at 60%RH

12.4.10 Gyro Removal from PCB

Never apply high mechanical force while removing MEMS gyros from PCB. Otherwise, the QFN package leads can be removed and failure analysis of the gyro unit will be impossible. Tweezers are practical.

Do not apply a pulling force upward. Instead apply a gentle force sideward while heating. When sufficient heat has been applied, the unit will start to slide sideways and can now be pulled gently upwards with the tweezers.

In any case, mechanical or thermo-mechanical overstress during manual handling and soldering, (especially contact between the soldering iron or hot air gun and the package) has to be avoided.

If safe removal of the suspected component is not possible or deemed too risky, send the whole PCB or the part of the PCB containing the defective component back to InvenSense. If requested, we will return the PCB after we have removed the gyro.

12.5 Package Marking Specification

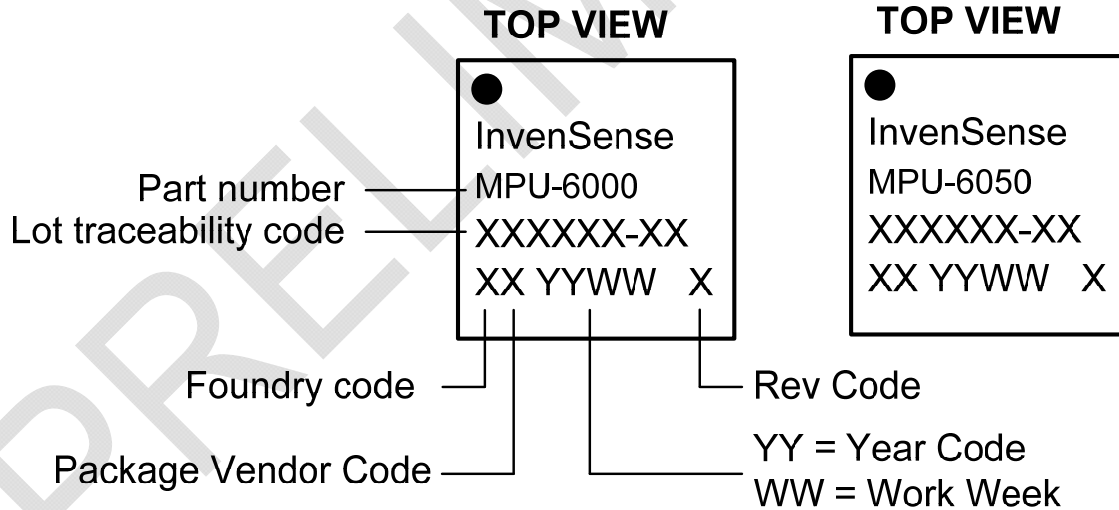

Package Marking Specification

12.6 Tape & Reel Specification

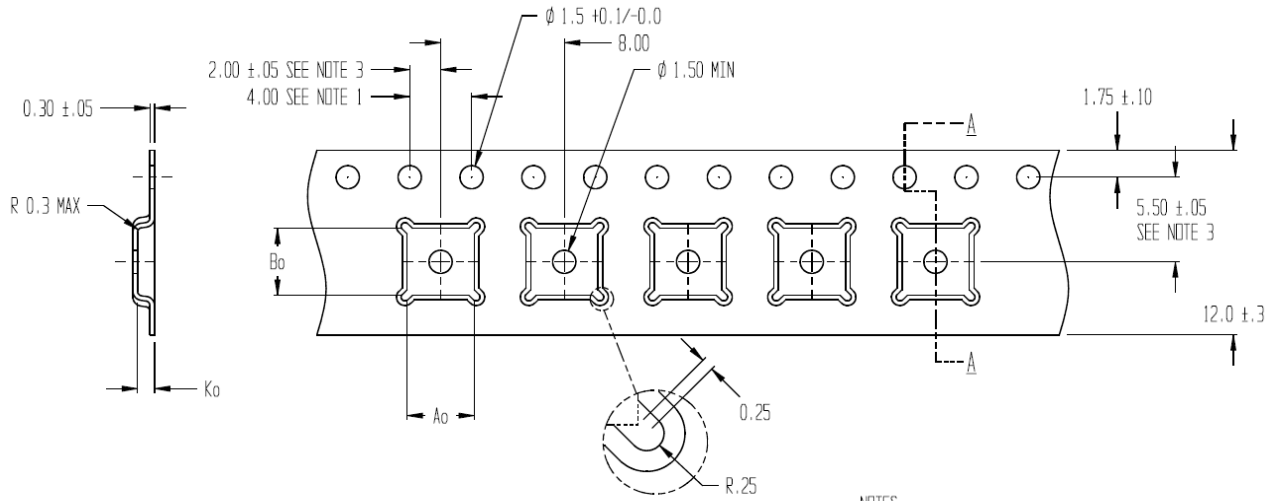

SECTION A - A

$A_o = 4.35$
 $B_o = 4.35$
 $K_o = 1.1$

TOLERANCES - UNLESS NOTED 1PL ± 0.2 2PL ± 0.10

ALL DIMENSIONS IN MILLIMETERS

Tape Dimensions

NOTES:

1. 10 SPROCKET HOLE PITCH CUMULATIVE TOLERANCE ± 0.2
2. CAMBER IN COMPLIANCE WITH EIA 481
3. POCKET POSITION RELATIVE TO SPROCKET HOLE MEASURED AS TRUE POSITION OF POCKET, NOT POCKET HOLE

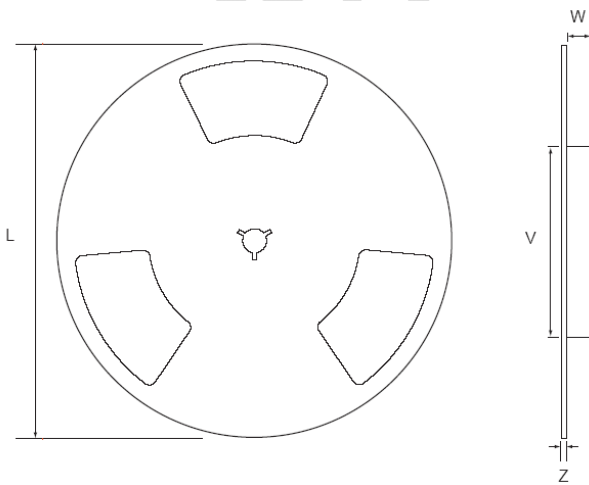

Reel Outline Drawing

Reel Dimensions and Package Size

PKG SIZE	REEL (mm)			
	L	V	W	Z

4x4	330	100	13.2	2.2
-----	-----	-----	------	-----

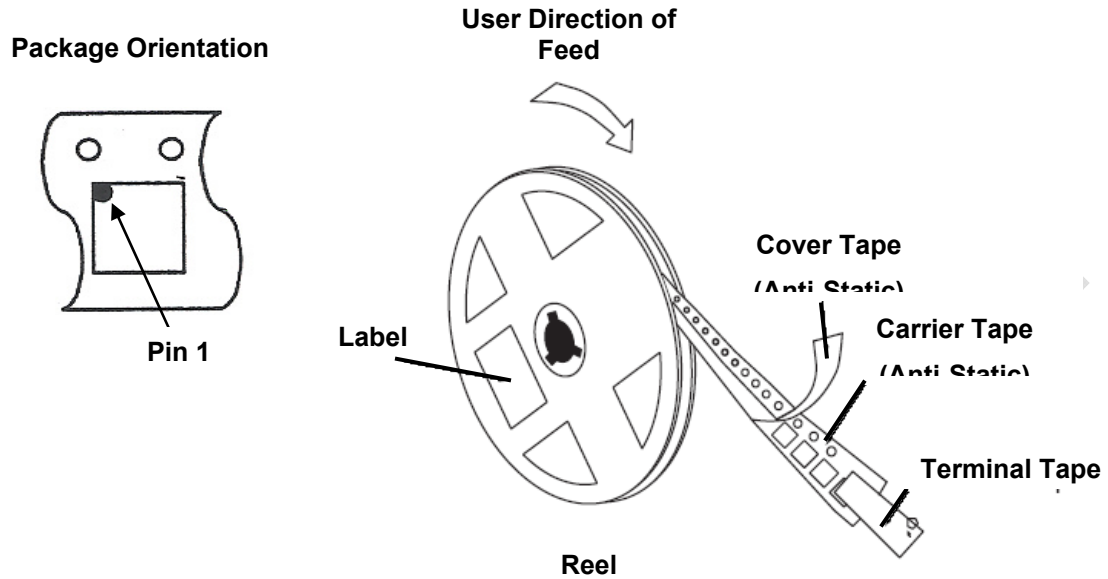
Tape and Reel Specification
Reel Specifications

Quantity Per Reel	5,000
Reels per Box	1
Boxes Per Carton (max)	3 full pizza boxes packed in the center of the carton, buffered by two empty pizza boxes (front and back).
Pcs/Carton (max)	15,000

12.7 Label

InvenSense		
DEVICE (IP) : MPU-6000	P.O.:	REEL QTY (Q) : 5000
LOT 1 (1T) : 123456-A	D/C (D) : 1234	QTY (Q) : 5000
LOT 2 (1T) :	D/C (D) :	QTY (Q) :
Reel Date : 13/10/09		QC STAMP



Location of Label

12.8 Packaging



Moisture Barrier Bag
With Labels

- ← Anti-static Label
- ← Moisture-Sensitive
- ← Caution Label
- ← Tape & Reel Label



Moisture-Sensitive Caution Label



Reel in Box



Box with Tape & Reel Label

13 Reliability

13.1 Qualification Test Policy

InvenSense's products complete a Qualification Test Plan before being released to production. The Qualification Test Plan for the MPU-60X0 followed the JEDEC 47G.01 Standards, "Stress-Test-Driven Qualification of Integrated Circuits," with the individual tests described below.

13.2 Qualification Test Plan

Accelerated Life Tests

TEST	Method/Condition	Lot Quantity	Sample / Lot	Acc / Reject Criteria
High Temperature Operating Life (HTOL/LFR)	JEDEC JESD22-A108C, Dynamic, 3.63V biased, T _j >125°C [read-points 168, 500, 1000 hours]	3	77	(0/1)
Highly Accelerated Stress Test ⁽¹⁾ (HAST)	JEDEC JESD22-A118 Condition A, 130°C, 85%RH, 33.3 psia., unbiased, [read-point 96 hours]	3	77	(0/1)
High Temperature Storage Life (HTS)	JEDEC JESD22-A103C, Cond. A, 125°C, Non-Biased Bake [read-points 168, 500, 1000 hours]	3	77	(0/1)

Device Component Level Tests

TEST	Method/Condition	Lot Quantity	Sample / Lot	Acc / Reject Criteria
ESD-HBM	JEDEC JESD22-A114F, (1.5KV)	1	3	(0/1)
ESD-MM	JEDEC JESD22-A115-A, (200V)	1	3	(0/1)
Latch Up	JEDEC JESD78B Level 2, 125C, +/- 60mA	1	6	(0/1)
Mechanical Shock	JEDEC JESD22-B104C, Mil-Std-883H, method 2002.5, Cond. E, 10,000g's, 0.2ms, ±X, Y, Z – 6 directions, 5 times/direction	3	5	(0/1)
Vibration	JEDEC JESD22-B103B, Variable Frequency (random), Cond. B, 5-500Hz, X, Y, Z – 4 times/direction	3	5	(0/1)
Temperature Cycling (TC) ⁽¹⁾	JEDEC JESD22-A104D Condition N, [-40°C to +85°C], Soak Mode 2 [5'], 100 cycles	3	77	(0/1)

Board Level Tests

TEST	Method/Condition	Lot Quantity	Sample / Lot	Acc / Reject Criteria
Board Mechanical Shock	JEDEC JESD22-B104C, Mil-Std-883H, method 2002.5, Cond. E, 10000g's, 0.2ms, +X, Y, Z – 6 directions, 5 times/direction	1	5	(0/1)
Board Temperature Cycling (TC) ⁽¹⁾	JEDEC JESD22-A104D Condition N, [-40°C to +85°C], Soak Mode 2 [5'], 100 cycles	1	40	(0/1)



(1) Tests are preceded by MSL3 Preconditioning in accordance with JEDEC JESD22-A113F

14 Environmental Compliance

The MPU-60X0 is RoHS and Green compliant.

The MPU-60X0 is in full environmental compliance as evidenced in report HS-MPU-6000A, Materials Declaration Data Sheet.

Environmental Declaration Disclaimer:

InvenSense believes this environmental information to be correct but cannot guarantee accuracy or completeness. Conformity documents for the above component constitutes are on file. InvenSense subcontracts manufacturing and the information contained herein is based on data received from vendors and suppliers, which has not been validated by InvenSense.

PRELIMINARY



This information furnished by InvenSense is believed to be accurate and reliable. However, no responsibility is assumed by InvenSense for its use, or for any infringements of patents or other rights of third parties that may result from its use. Specifications are subject to change without notice. InvenSense reserves the right to make changes to this product, including its circuits and software, in order to improve its design and/or performance, without prior notice. InvenSense makes no warranties, neither expressed nor implied, regarding the information and specifications contained in this document. InvenSense assumes no responsibility for any claims or damages arising from information contained in this document, or from the use of products and services detailed therein. This includes, but is not limited to, claims or damages based on the infringement of patents, copyrights, mask work and/or other intellectual property rights.

Certain intellectual property owned by InvenSense and described in this document is patent protected. No license is granted by implication or otherwise under any patent or patent rights of InvenSense. This publication supersedes and replaces all information previously supplied. Trademarks that are registered trademarks are the property of their respective companies. InvenSense sensors should not be used or sold in the development, storage, production or utilization of any conventional or mass-destructive weapons or for any other weapons or life threatening applications, as well as in any other life critical applications such as medical equipment, transportation, aerospace and nuclear instruments, undersea equipment, power plant equipment, disaster prevention and crime prevention equipment.

InvenSense® is a registered trademark of InvenSense, Inc. MPU™, MPU-6000™, MPU-6050™, MPU-60X0™, Motion Processing Unit™, Digital Motion Processing™, and DMP™ are trademarks of InvenSense, Inc.

©2010 InvenSense, Inc. All rights reserved.

