



InvenSense Inc.
1197 Borregas Ave, Sunnyvale, CA 94089 U.S.A.
Tel: +1 (408) 988-7339 Fax: +1 (408) 988-8104
Website: www.invensense.com

PS-ISZ-0650B-00-02
Release Date: 07/08/09

ISZ-650 Single-Axis Z-Gyro Product Specification

A printed copy of this document is
NOT UNDER REVISION CONTROL
unless it is dated and stamped in red ink as,
"REVISION CONTROLLED COPY."



TABLE OF CONTENTS

1. REVISION HISTORY	4
2. PURPOSE AND SCOPE	5
3. PRODUCT OVERVIEW	5
4. FEATURES	5
5. FUNCTIONAL BLOCK DIAGRAM	6
6. FUNCTIONAL DESCRIPTION	6
6.1 OVERVIEW	6
6.2 RATE SENSOR	6
6.3 OSCILLATOR CIRCUIT	6
6.4 AMPLITUDE CONTROL	6
6.5 CORIOLIS SENSE	7
6.6 DEMODULATOR	7
6.7 LOW-PASS FILTER	7
6.8 AUTO ZERO	7
6.9 TEMPERATURE SENSOR	7
6.10 CHARGE PUMP	7
6.11 MEMORY TRIM	7
6.12 SCALE FACTOR	7
6.13 REFERENCE VOLTAGE	7
6.14 ANALOG OUTPUTS	7
7. SPECIFICATION	8
7.1 SPECIFIED PARAMETERS	8
7.2 SPECIFIED PARAMETERS, CONTINUED	9
7.3 RECOMMENDED OPERATING CONDITIONS	9
7.4 ABSOLUTE MAXIMUM RATINGS	9
7.5 REFERENCE CIRCUIT	10
8. APPLICATION INFORMATION	11
8.1 PIN OUT AND SIGNAL DESCRIPTION	11
8.2 DESIGN CONSIDERATIONS	12
8.2.1 POWER SUPPLY REJECTION RATIO	12
8.2.2 POWER SUPPLY FILTERING	12
8.2.3 AMPLITUDE CONTROL	12
8.2.4 TEMPERATURE SENSOR	12
8.2.5 INTERNAL LOW-PASS FILTER	12



8.2.6	EXTERNAL LOW-PASS CIRCUITRY	13
8.2.7	GYRO OUTPUTS	13
8.2.8	AUTO ZERO	13
8.2.9	HIGH IMPEDANCE NODES	14
8.2.10	CHARGE PUMP	14
8.2.11	PROPER INTERFACE CLEANING	14
8.2.12	ACOUSTIC NOISE SENSITIVITY	14
8.2.13	ELECTROSTATIC DISCHARGE SENSITIVITY	14
9.	ASSEMBLY	15
9.1	PACKAGE DIMENSIONS	15
9.2	PACKAGE MARKING SPECIFICATION	16
9.3	TAPE & REEL SPECIFICATION	16
9.4	LABEL	18
9.5	PACKING	18
9.6	TRACE ROUTING	19
9.7	SOLDERING EXPOSED DIE PAD	19
9.8	COMPONENT PLACEMENT	19
9.9	AGC NODE	19
9.10	MEMS HANDLING INSTRUCTIONS	19
9.11	GYROSCOPE SURFACE MOUNT GUIDELINES	19
9.12	PCB MOUNTING AND CROSS-AXIS SENSITIVITY	19
9.13	REFLOW SPECIFICATION	21
9.14	STORAGE SPECIFICATIONS	22
10.	RELIABILITY	22
10.1	QUALIFICATION TEST POLICY	22
10.2	QUALIFICATION TEST PLAN	22
11.	ENVIRONMENTAL COMPLIANCE	23

	ISZ-650 Single-Axis Z-Gyroscope Product Specification	PS-ISZ-0650B-00-02 Release Date: 07/08/09
---	--	--

1. Revision History

Revision Date	Revision	Description
02/04/09	01	Initial Release
07/08/09	02	Reversed orientation of positive Z-axis rotation; removed package landing diagram; new solder reflow specifications; updated environmental compliance section; updated qualification test policy; moved disclaimer to end of document and changed wording; various other figure and wording changes.



2. Purpose and Scope

This document is a preliminary product specification, providing a description, specifications, and hardware design related information relating to the ISZ-650 gyroscope.

Electrical characteristics in this preliminary document are based upon simulation results and limited characterization data of advanced samples only. Specifications are subject to change without notice. Final specifications will be updated based upon characterization of final silicon.

3. Product Overview

The ISZ-650 is a state-of-the-art single-axis Z-gyroscope designed specifically for complex motion sensing in 3D-input devices and gaming controllers. The ISZ-650 gyroscope utilizes state-of-the-art MEMS fabrication with wafer-scale integration technology. This technology combines completed MEMS wafers and completed CMOS electronic wafers together using a patented and proprietary wafer-scale bonding process that simultaneously provides electrical connections and hermetically sealed enclosures. This unique and novel fabrication technique is the key enabling technology that allows for the design and manufacture of high performance, integrated MEMS gyroscopes in a very small and economical package. Integration at the wafer-level minimizes parasitic capacitances, allowing for improved signal-to-noise over a discrete solution. With the addition of the new patent-pending Auto Zero feature for minimizing bias drift over temperature, the ISZ-650 offers unparalleled gyroscope performance in 3D-input and gaming applications.

4. Features

By integrating the control electronics with the sensor elements at the wafer level, the ISZ-650 gyroscope supports a rich feature set including:

- Z-axis (yaw rate) gyro on a single chip
- Two separate analog outputs for standard and high sensitivity:
 - Z-Out Pin: 2000°/s full scale range
0.5mV/°/s sensitivity
 - Z4.5Out Pin: 440°/s full scale range
2.27mV/°/s sensitivity
- Integrated amplifiers and low-pass filter
- Auto-Zero function
- On-chip temperature sensor
- High vibration rejection over a wide frequency range
- High cross-axis isolation by proprietary MEMS design
- 3V single-supply operation
- Hermetically sealed for temperature and humidity resistance
- 10,000 g shock tolerant
- Smallest single axis gyro package at 4 x 5 x 1.2mm
- RoHS and Green Compliant

5. Functional Block Diagram

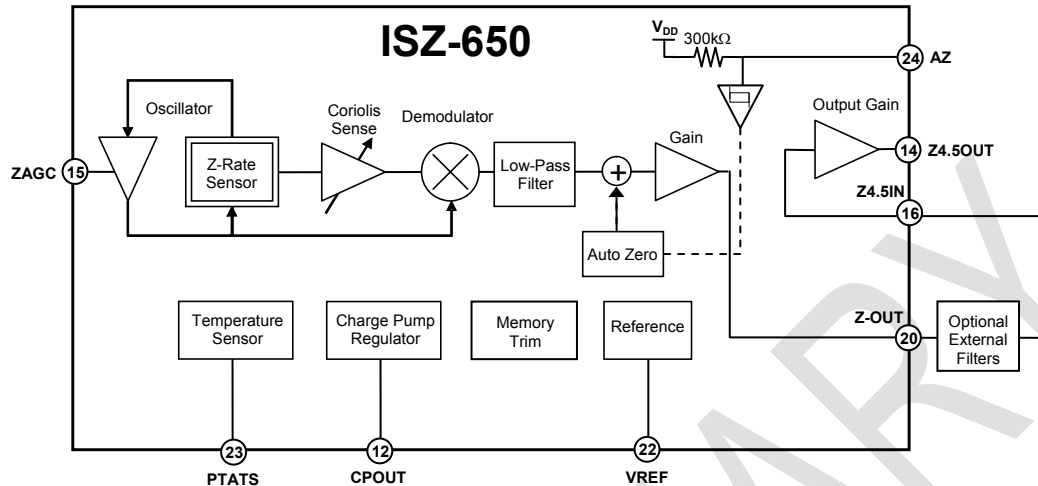

Figure 1

6. Functional Description

6.1 Overview

The ISZ-650 gyroscope consists of a dual-mass, vibratory MEMS gyroscope. The gyroscope measures rotation rate about the Z-axis, the axis normal to the surface of the package.

The gyroscope's proof-masses are electrostatically oscillated at resonance. An internal automatic gain control circuit precisely controls the oscillation of the proof masses. When the sensor is rotated about the Z-axis, the Coriolis Effect causes a vibration that can be detected by a capacitive pickoff. The resulting signal is amplified, demodulated, and filtered to produce an analog voltage that is proportional to the angular rate.

6.2 Rate Sensor

The mechanical structure for detecting angular rate about the Z-axis is fabricated using InvenSense's proprietary bulk silicon technology. The structure is covered and hermetically sealed at the wafer level. The cover shields the gyro from electromagnetic and radio frequency interferences (EMI/RFI). The dual-mass design inherently rejects any signal caused by linear acceleration.

6.3 Oscillator Circuit

The oscillator circuit generates electrostatic forces to vibrate the structure at resonance. The circuit detects the vibration by measuring the capacitance between the oscillating structure and a fixed electrode. The oscillator circuit switches in quadrature phase with the capacitance measurement in order to vibrate at resonance.

6.4 Amplitude Control

The scale factor of the gyroscope depends on the amplitude of the mechanical motion and the trim setting of the internal programmable gain stages. The oscillation circuit precisely controls the amplitude to maintain constant sensitivity over the operating temperature range.



6.5 Coriolis Sense

Rotating the sensor about the Z-axis results in a Coriolis force on the Z-rate sensor. The Coriolis force causes the mechanical structure to vibrate in-plane. The resulting vibration is detected by measuring the capacitance change between the mechanical structure and fixed electrodes. This signal is converted to a voltage waveform by means of low-noise charge integrating amplifier and amplification stages.

6.6 Demodulator

The output of the Coriolis sense is an amplitude modulated waveform. The amplitude corresponds to the rotation rate, and the carrier frequency is the mechanical drive frequency. The synchronous demodulator converts the Coriolis sense waveform to the low-frequency, angular rate signal.

6.7 Low-Pass Filter

After the demodulation stage, there is a low-pass filter. This filter attenuates noise and high frequency artifacts before final amplification.

6.8 Auto Zero

The Auto Zero function is used to reduce DC offset caused by bias drift. The implementation of this function will vary by application requirement. Pin 24 (AZ) is used to set the Auto Zero function, resetting the bias to approximately VREF.

6.9 Temperature Sensor

A built-in Proportional-To-Absolute-Temperature (PTAT) sensor provides temperature information on Pin 23.

6.10 Charge Pump

The on-chip charge pump generates the voltage required to oscillate the mechanical structure.

6.11 Memory Trim

The on-chip memory is used to select the gyro's sensitivity, calibrate the sensitivity, null DC offsets and select the low-pass filter option

6.12 Scale Factor

The Rate-Out of the gyro is not ratiometric to the supply voltage. The scale factor is calibrated at the factory and is nominally independent of supply voltage.

6.13 Reference Voltage

The gyro includes a bandgap reference circuit. The output voltage is typically 1.35V and is nominally independent of temperature. The zero-rate signal is nominally equal to the reference value.

6.14 Analog Outputs

The ISZ-650 gyro has two Z-outputs (Z-OUT and Z4.5OUT), with scale factors and full-scale sensitivities that vary by a factor of 4.5, as detailed in Section 8.2.7.

Having two sensitivities and two full-scale ranges for the one axis allows the end user to have one output that can be used for faster motions (over a full scale range of $\pm 2000^\circ/\text{sec}$), and a second output that can be used for slower motions (over a full scale range of $\pm 440^\circ/\text{sec}$). Thus a lower-resolution analog-to-digital converter (ADC) may be used to digitize the motion, with the gain of 4.5 in the Z4.5OUT output effectively giving the user additional two-plus bits of resolution.



**ISZ-650 Single-Axis Z-Gyroscope
Product Specification**

PS-ISZ-0650B-00-02
Release Date: 07/08/09

7. Specification

7.1 Specified Parameters

All parameters specified are @ VDD = 3.0 V and T_A = 25°C. External LPF @ 2kHz.

PARAMETER	CONDITIONS	MIN	TYP	MAX	UNITS
SENSITIVITY					
Full-Scale Range	At Z-OUT At Z4.5OUT		±2000 ±440		°/s °/s
Sensitivity	At Z-OUT At Z4.5OUT		0.5 2.27		mV/°/s mV/°/s
Initial Calibration Tolerance	At Z-OUT		±6		%
Calibration Drift Over Specified Temperature	At Z-OUT		±10		%
Nonlinearity	At Z-OUT, Best Fit Straight Line		0.5		% of FS
Cross-axis Sensitivity			±1		%
REFERENCE					
Voltage (VREF)			1.35		V
Tolerance			±50		mV
Load Drive			100		µA
Capacitive Load Drive	Load directly connected to VREF		100		pF
Power Supply Rejection	VDD= 2.7V to 3.3V		1		mV/V
Reference Drift Over Specified Temperature			±5		mV
ZERO-RATE OUTPUT (ZRO)					
Static Output (Bias)	Factory Set		1.35		V
Initial Calibration Tolerance	Relative to VREF		±20		mV
			±150		
ZRO Drift Over Specified Temperature			±20		mV
Power Supply Sensitivity	@ 50 Hz		10		°/sec/V
FREQUENCY RESPONSE					
High Frequency Cutoff	Internal LPF -90°		140		Hz
LPF Phase Delay	10Hz		-4.5		°
MECHANICAL FREQUENCY					
Z-Axis Resonant Frequency		26	30	34	kHz
NOISE PERFORMANCE					
Total RMS Noise	Bandwidth 1Hz to 1kHz, At Z-OUT		0.3		mV rms
OUTPUT DRIVE CAPABILITY					
Output Voltage Swing	Load = 100kΩ to VDD/2	0.05		VDD-0.05	V
Capacitive Load Drive			100		pF
Output Impedance			200		Ω
POWER ON-TIME					
Zero-Rate Output	Settling to ±3°/s		50	200	ms
AUTO ZERO CONTROL					
AZ Logic High	Rising Input		1.9		V
AZ Logic Low	Falling Input		0.9		V
Auto Zero Pulse Duration		2		1500	µsec
Offset Settle Time After Auto Zero			7		msec

	ISZ-650 Single-Axis Z-Gyroscope Product Specification	PS-ISZ-0650B-00-02 Release Date: 07/08/09
---	--	--

7.2 Specified Parameters, continued

All parameters specified are @ VDD = 3.0 V and T_A = 25°C. External LPF @ 2kHz.

PARAMETER	CONDITIONS	MIN	TYP	MAX	UNITS
POWER SUPPLY (VDD) Operating Voltage Range Quiescent Supply Current Supply Current Change Over Specified Temperature		2.7	3.0 4.5 ±1	3.3	V mA mA
TEMPERATURE SENSOR Sensitivity Offset Output Impedance	Range -20 to +85°C		4 1.25 12		mV/°C V kΩ
TEMPERATURE RANGE Specified Temperature Range		-20		+85	°C

7.3 Recommended Operating Conditions

Parameter	Min	Typ	Max	Unit
Power Supply Voltage (VDD)	2.7	3.0	3.3	V
Power Supply Voltage (VDD) Rise Time (10% - 90%)			20	ms

7.4 Absolute Maximum Ratings

Stress above those listed as “Absolute Maximum Ratings” may cause permanent damage to the device. This is a stress rating only and functional operation of the device under these conditions is not implied. Exposure to the absolute maximum rating conditions for extended periods may affect device reliability.

Parameter	Rating
Supply Voltage	-0.3V to +3.6V
Acceleration (Any Axis, unpowered)	10,000g for 0.3ms
Operating Temperature Range	-40 to +105°C
Storage Temperature Range	-40 to +125°C

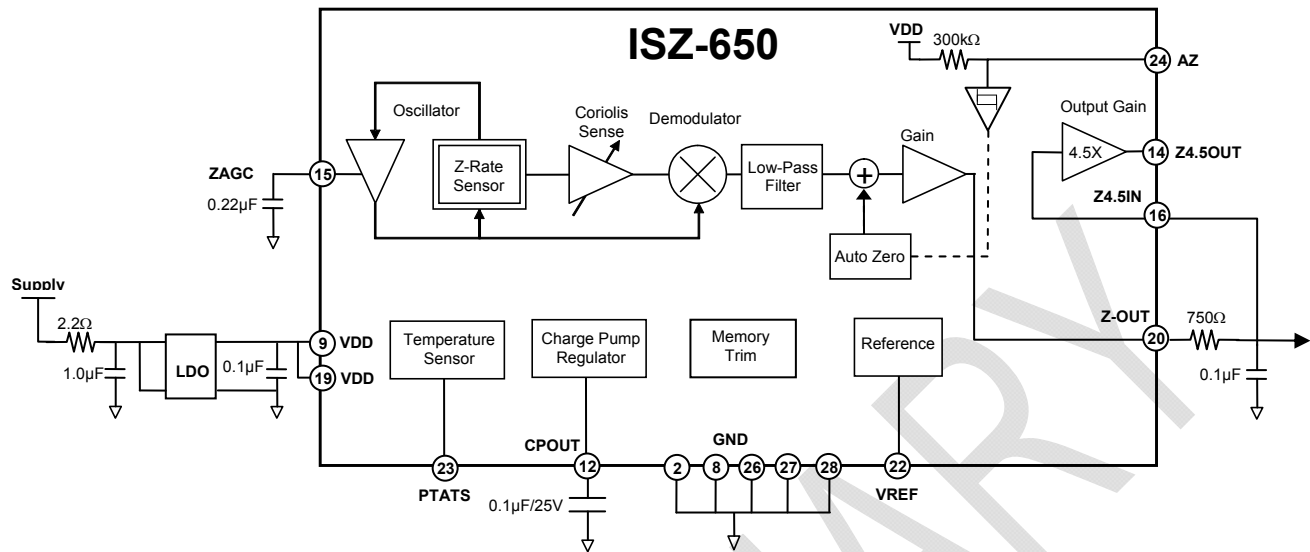
7.5 Reference Circuit

Figure 2
Bill of Material for External Components

Component	Specification
Low Pass Filter Capacitor	0.1μF ±20% / 10V
AGC Capacitor	0.22μF ±10% / 10V
VDD Bypass Capacitor	0.1μF ±20% / 10V
Charge Pump Capacitor	0.1μF ±20% / 25V
LDO Input Filter Capacitor	1.0μF / Ratings Dependent upon Supply Voltage
LDO Input Filter Resistor	2.2Ω ±1%
Low Pass Filter Resistor	750Ω ±1%

8. Application Information

8.1 Pin Out and Signal Description

Number	Pin	Description
2, 8, 26, 27, 28	GND	Ground
9, 19	VDD	Positive supply voltage
12	CPOUT	Charge pump capacitor connection
14	Z4.5OUT	Z-axis output of the 4.5X amplifier ($\pm 440^\circ/\text{sec}$ FSR)
15	ZAGC	Amplitude control capacitor connection
16	Z4.5IN	Z-axis input to the 4.5X amplifier
20	Z-OUT	Rate output for rotation about the Z-axis ($\pm 2000^\circ/\text{sec}$ FSR)
22	VREF	Precision reference output
23	PTATS	Temperature Sensor Output
24	AZ	Auto Zero control pin
10, 11, 13, 21, 25	RESV	Reserved. Do not connect.
1, 3, 4, 5, 6, 7, 17, 18	NC	Not internally connected. May be used for PCB trace routing.

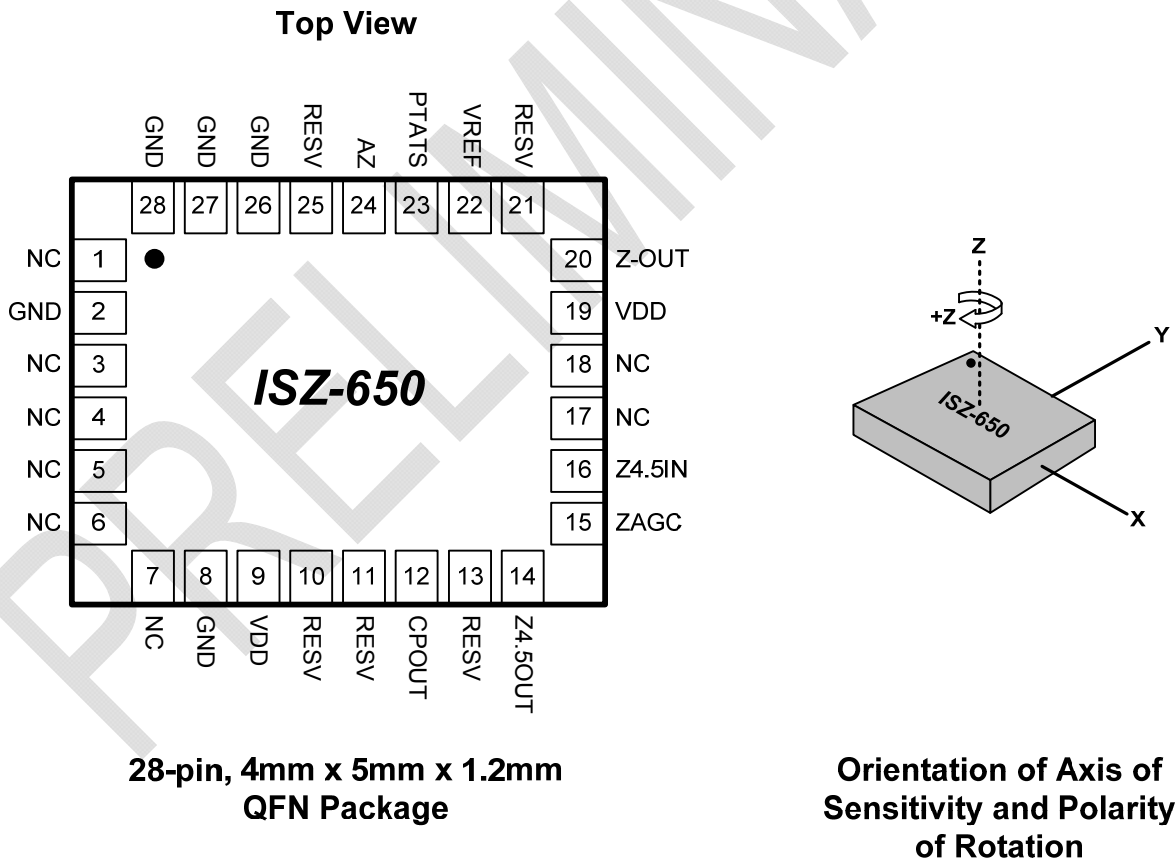

Figure 3

8.2 Design Considerations

8.2.1 Power Supply Rejection Ratio

The gyro is most susceptible to power supply noise (ripple) at frequencies less than 100Hz. At less than 100Hz, the PSRR is determined by the overall internal gain of the gyroscope. Above 100Hz, the PSRR is determined by the characteristics of the on-chip low-pass filter. Above 1kHz, the PSRR is relatively constant except for a narrow frequency range corresponding to the resonant frequency of the Z-gyroscope.

8.2.2 Power Supply Filtering

The Power Supply Voltage (VDD) rise time (10% - 90%) must be less than 20ms at VDD (Pins 9 and 19) for proper device operation.

The ISZ-650 gyroscope should be isolated from system power supply noise by a combination of an RC filter that attenuates high frequency noise and a Low Drop Out linear regulator (LDO) that attenuates low frequency noise. Figure 4 shows a typical configuration.

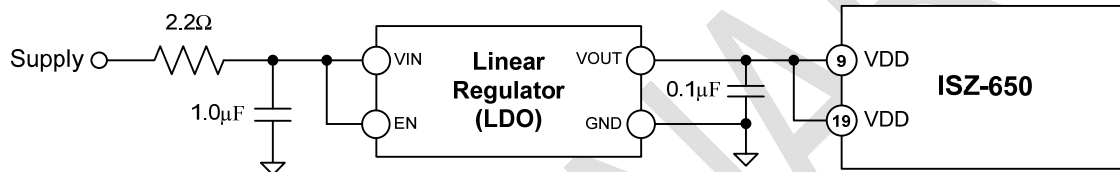

Figure 4

The low-pass RC filter should be chosen such that it provides significant attenuation of system noise at high frequencies. The LDO should be a low noise regulator ($<100\mu\text{V}/\text{rtHz}$) that exhibits good noise rejection at low frequencies.

8.2.3 Amplitude Control

The scale factor of the gyroscope depends on the amplitude of the mechanical motion and the trim setting of the internal programmable gain stages. The oscillation circuit precisely controls the amplitude to maintain constant sensitivity over the specified temperature range. The capacitor connected to Pin 15 (ZAGC) is a compensation capacitor for the amplitude control loop.

8.2.4 Temperature Sensor

A built-in Proportional-To-Absolute-Temperature (PTAT) sensor provides temperature information on Pin 23 (PTATS). The temperature sensor output signal is analog, and has a bias of approximately 1.25V at room temperature, and increases at a rate of $4\text{mV}/^\circ\text{C}$. The output impedance is nominally $12\text{k}\Omega$ and is therefore not designed to drive low impedance loads. If necessary, the output can be externally buffered with a low offset-drift buffer, and optionally a low-pass filter to minimize noise.

8.2.5 Internal Low-Pass Filter

After the demodulation stage, there is a low-pass filter. This filter limits noise and high frequency artifacts from the demodulator before final amplification. The following graph shows the typical gain and phase response. The low-pass filter has been designed for a nominally flat gain up to the cutoff frequency while still achieving a low phase delay at 10Hz and 30Hz.

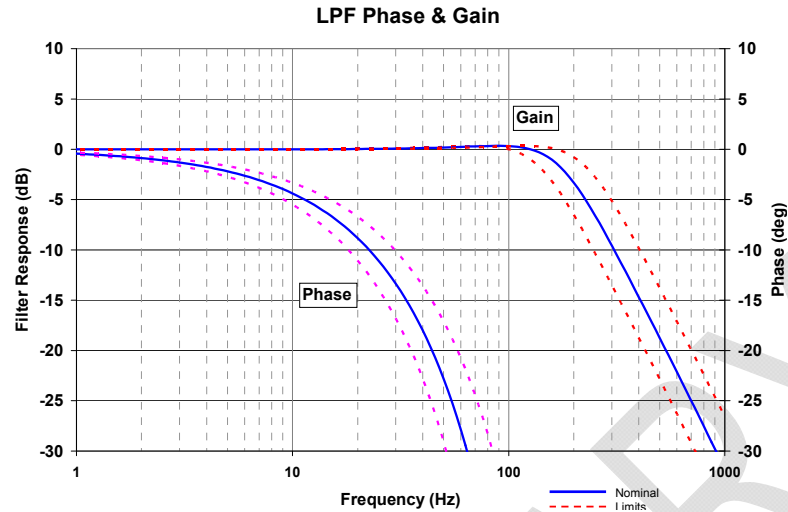

Figure 5

8.2.6 External Low-Pass Circuitry

To further attenuate high-frequency noise, an optional external low-pass filter may be used.

8.2.7 Gyro Outputs

The ISZ-650 gyro has two Z-outputs, with scale factors and full-scale sensitivities as summarized below.

Axis	Gyro Output	Sensitivity (mV/°/s)	Full-Scale Range (±°/s)
Z	Z-OUT	0.5	2000
	Z4.5OUT	2.27	440

Having two sensitivities and two full-scale ranges for one axis allows the end user to have one output that can be used for faster motions such as full-motion gaming (over a full scale range of ±2000°/sec), and a second output that can be used for slower motions such as for gesture and menu-navigation functionality (over a full scale range of ±440°/sec). Thus a lower-resolution analog-to-digital converter (ADC) may be used to digitize the motion, with the gain of 4.5 in the Z4.5OUT output effectively giving the user additional two-plus bits of resolution.

The ISZ-650 gyro outputs are independent of supply voltage (i.e. they are not ratiometric).

Gyro rotation rate is calculated as:

$$\frac{(\text{Gyro Output Voltage} - \text{Gyro Zero-Rate Out})}{\text{Sensitivity}}$$

where the Zero-Rate Output (ZRO) is nominally VREF. There is a temperature dependence to ZRO, and an initial accuracy to ZRO.

8.2.8 Auto Zero

Auto Zero (AZ) is a function that is used to maximize the gyro's dynamic range when using the Z4.5OUT output.

AZ works by keeping the gyro's Zero-Rate Output (ZRO) close to VREF, and thus allows the user to achieve a wider usable signal range, without using an external analog high pass filter.

When activated, the Auto Zero circuit internally nulls the ZRO to approximately VREF. The typical usage of Auto Zero is in conditions where:

1. The gyro's motion is known, such as when:
 - a. The gyro is stationary.
 - b. Other sensors can report angular rotation rate.
2. The DC value of the gyro output is not important, but only the AC value is. In this case, a digital ac filter may be used to extract the gyro data, which provides a higher-quality output than is possible with an analog R-C filter.

The Auto Zero function is initiated on the rising edge of the AZ pin. The Auto Zero settling time is typically 7ms. This time includes the time required for nulling the ZRO and for the settling of the internal low pass filter (LPF). If the external LPF bandwidth is less than 200Hz, the Auto Zero settling time will be longer than specified.

The AZ pulse width should meet the specified minimum time requirement of 2 μ s to start the Auto Zero function, and should be shorter than the maximum specified time of 1,500 μ s. The Auto Zero pulse should occur after the start-up period to cancel any initial calibration error.

8.2.9 High Impedance Nodes

The ZAGC pin is a high impedance node (>1Mohm). Any coating, glue or epoxy on this pin or on the capacitor connected to this pin, will affect part performance and should be avoided.

8.2.10 Charge Pump

The on-chip charge pump requires a capacitor for stable operation. This capacitor should be 0.1 μ F and rated for 25V.

8.2.11 Proper Interface Cleaning

Proper cleaning of PCB solder pads prior to assembly is recommended. PCB surface contaminants at pin 15 may affect part performance.

8.2.12 Acoustic Noise Sensitivity

The ISZ-650 gyroscope is insensitive to vibration except for a narrow frequency range near the gyro's resonant frequency and at odd multiples of the resonant frequency. The typical bandwidth of the acoustic sensitivity is 200Hz. It is recommended that products using the ISZ-650 gyroscope along with mechanical actuators be designed such that the acoustic noise in the 20kHz to 31kHz range be attenuated by the product's enclosure avoids these frequency ranges.

8.2.13 Electrostatic Discharge Sensitivity

The ISZ-650 gyroscope can be permanently damaged by an electrostatic discharge. ESD precautions for handling and storage are recommended.

9. Assembly

9.1 Package Dimensions

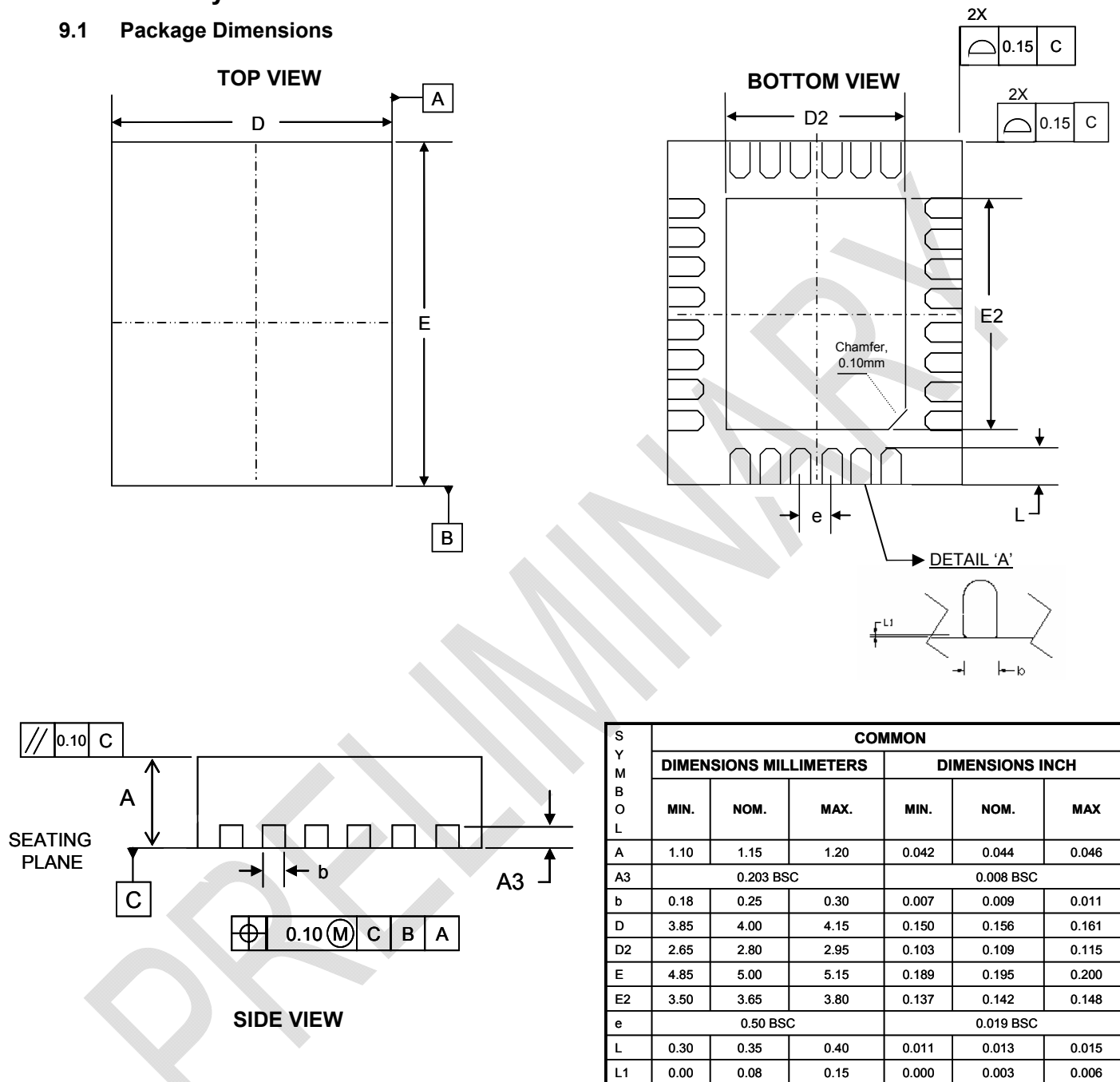
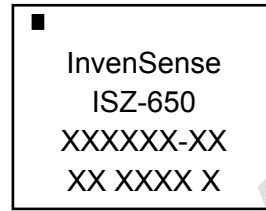

Figure 6

9.2 Package Marking Specification

- Line 1 = Company Name
- Line 2 = Part Number
- Line 3 = Lot Traceability Code
- Line 4 = Fabricator, Assembly, Date Code, Revision



Top View

9.3 Tape & Reel Specification

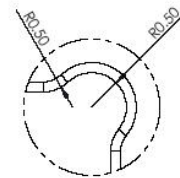
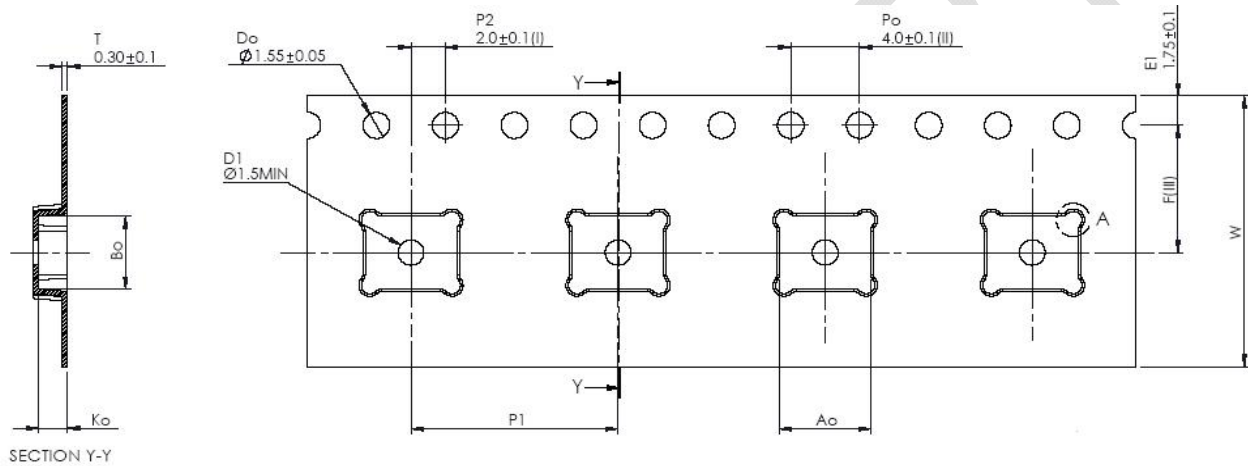

DETAIL 'A'

- (I) Measured from centerline of sprocket hole to centerline of pocket.
 - (II) Cumulative tolerance of 10 sprocket holes is ± 0.20 .
 - (III) Measured from centerline of sprocket holes to centerline of pocket.
 - (IV) Other material available.
- ALL DIMENSIONS IN MILLIMETERS UNLESS OTHERWISE STATED.

PKG SIZE	CARRIER TAPE (mm)							
	Tape Width (W)	Pocket Pitch (P1)	Ao	Bo	Ko	F	Leader Length (Min.)	Trailer Length (Min.)
4x5	16.00 ±0.3	12.00 ±0.1	5.30 ±0.1	4.30 ±0.1	1.65 ±0.1	7.50 ±0.1	300	300

Figure 7

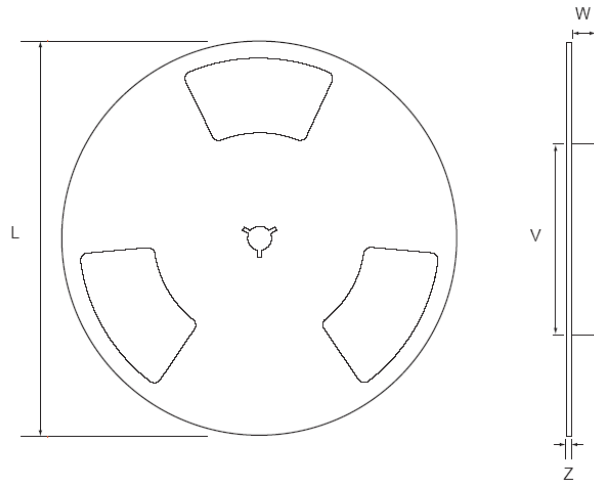

Figure 8

PKG SIZE	REEL (mm)			
	L	V	W	Z
4x5	330	100	16.4	3.0

Package Orientation

User Direction of Feed

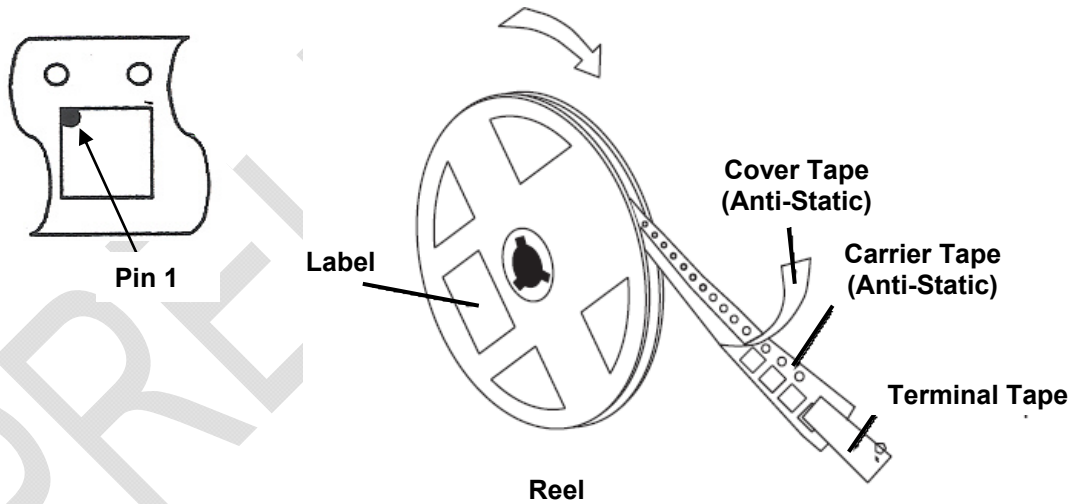

Figure 9

Quantity Per Reel	5000
Reels per Pizza Box	1
Pizza Boxes Per Carton (max)	3 full pizza boxes packed in the center of the carton, buffered by two empty pizza boxes (front and back).
Pieces/Carton (max)	15,000

9.4 Label

InvenSense

DEVICE (1P) : ISZ-650A	P.O.:	REEL QTY (Q) :3000
		
LOT 1 (IT) : 123456-7	D/C (D) : 0925	QTY (Q) : 3000
		
LOT 2 (IT) :	D/C (D) :	QTY (Q) :
		
Reel Date : 24/06/09		QC STAMP



Location of Label

9.5 Packing



Moisture Barrier Bag
With Labels

Anti-static Label
Moisture-Sensitive
Caution Label
Tape & Reel Label



Moisture-Sensitive Caution Label



Reel in Pizza Box



Pizza Box with Tape & Reel Label



9.6 Trace Routing

Routing traces or vias under the gyro package such that they run under the exposed die pad is prohibited.

9.7 Soldering Exposed Die Pad

The exposed die pad is internally connected to VSS, and should not be soldered to the PCB since soldering to it contributes to performance changes due to package thermo-mechanical stress.

9.8 Component Placement

There are no specific design considerations other than generally accepted industry design practices for component placement near the ISZ-650 gyroscope to prevent noise coupling.

9.9 AGC Node

The gyro pin marked ZAGC is a high impedance node that is sensitive to current leakage, which can impact gyroscope performance. Care should be taken to ensure that this node is not contaminated by residue such as flux and is clean.

9.10 MEMS Handling Instructions

MEMS (Micro Electro-Mechanical Systems) are a time-proven, robust technology used in hundreds of millions of consumer, automotive and industrial products. MEMS devices consist of microscopic moving mechanical structures. They differ from conventional IC products even though they can be found in similar packages. Therefore, MEMS devices require different handling precautions than conventional ICs prior to mounting onto printed circuit boards (PCBs).

InvenSense's ISZ-650 gyroscopes have a shock tolerance of 10,000g. InvenSense packages its gyroscopes as it deems proper for protection against normal handling and shipping. It recommends the following handling precautions to prevent potential damage:

- Individually packaged gyroscopes or trays of gyroscopes should not be dropped on hard surfaces. Components placed in trays could be subject to *g*-forces in excess of 10,000g if dropped.
- Printed circuit boards that incorporate mounted gyroscopes should not be separated by manually snapping apart. This could also create *g*-forces in excess of 10,000g.

9.11 Gyroscope Surface Mount Guidelines

Any material used in the surface mount assembly process of the MEMS gyroscope should be free of restricted RoHS elements or compounds. Pb-free solders should be used for assembly.

In order to assure gyroscope performance, several industry standard guidelines need to be considered for surface mounting. These guidelines are for both printed circuit board (PCB) design and surface mount assembly and are available from packaging and assembly houses.

When using MEMS gyroscope components in plastic packages, package stress due to PCB mounting and assembly could affect the output offset and its value over a wide range of temperatures. This is caused by the mismatch between the Coefficient Temperature Expansion (CTE) of the package material and the PCB. Care must be taken to avoid package stress due to mounting.

9.12 PCB Mounting and Cross-Axis Sensitivity

Orientation errors of the gyroscope mounted to the printed circuit board can cause cross-axis sensitivity in which one gyro responds to rotation about another axis, for example, the Z-axis gyroscope responding to rotation about the X or Y axes. The orientation mounting errors are illustrated in the figure below.

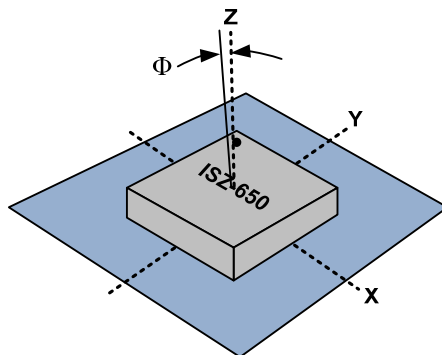

Package Gyro Axes (.....) Relative to PCB Axes (———) with Orientation Error (Φ)

Figure 10

The table below shows the cross-axis sensitivity as a percentage of the specified gyroscope's sensitivity for a given orientation error.

Cross-Axis Sensitivity vs. Orientation Error

Orientation Error (Φ)	Cross-Axis Sensitivity ($\sin\Phi$)
0°	0%
0.5°	0.87%
1°	1.75%

The specification for cross-axis sensitivity in Section 7 includes the effect of the die orientation error with respect to the package.

9.13 Reflow Specification

The approved solder reflow curve shown in the figure below conforms to IPC/JEDEC J-STD-020D.01 (Moisture/Reflow Sensitivity Classification for Non hermetic Solid State Surface Mount Devices) with a maximum peak temperature ($T_c = 260^{\circ}\text{C}$). This is specified for component-supplier reliability qualification testing using lead-free solder for package thicknesses less than 1.6 mm. The reliability qualification pre-conditioning used by InvenSense incorporates three of these conforming reflow cycles. All temperatures refer to the topside of the QFN package, as measured on the package body surface. Customer solder-reflow processes should use the solder manufacturer's recommendations, making sure to never exceed the constraints listed in the table and figure below, as these represent the maximum tolerable ratings for the device. For optimum results, production solder reflow processes should use lower temperatures, reduced exposure times to high temperatures, and lower ramp-up and ramp-down rates than those listed below.

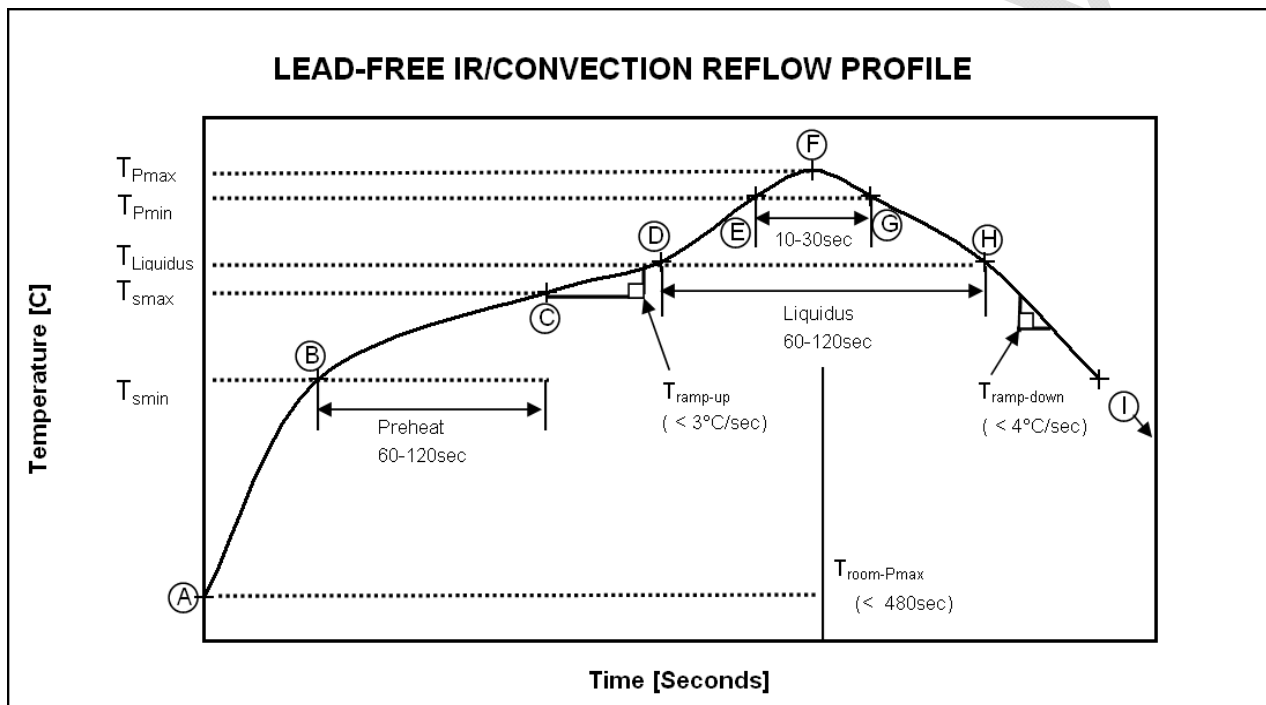

Approved IR/Convection Solder Reflow Curve

Temperature Set Points for IR / Convection Reflow Corresponding to Figure Above

Step	Setting	CONSTRAINTS		
		Temp ($^{\circ}\text{C}$)	Time (sec)	Rate ($^{\circ}\text{C}/\text{sec}$)
A	T_{room}	25		
B	T_{Smin}	150		
C	T_{Smax}	200	$60 < t_{\text{BC}} < 120$	
D	T_{Liquidus}	217		$r_{(\text{TL}-\text{TPmax})} < 3$
E	T_{Pmin} [$\leq T_{\text{Pmax}}-5^{\circ}\text{C}, 255^{\circ}\text{C}$]	255		$r_{(\text{TL}-\text{TPmax})} < 3$
F	T_{Pmax} [260 $^{\circ}\text{C}$]	260 -0/+5 $^{\circ}\text{C}$	$t_{\text{AF}} < 480$	$r_{(\text{TL}-\text{TPmax})} < 3$
G	T_{Pmin}	255	$t_{\text{EG}} < 30$	$r_{(\text{TPmax}-\text{TL})} < 6$
H	T_{Liquidus}	217	$60 < t_{\text{DH}} < 120$	
I	T_{room}	25		

	ISZ-650 Single-Axis Z-Gyroscope Product Specification	PS-ISZ-0650B-00-02 Release Date: 07/08/09
---	--	--

9.14 Storage Specifications

The storage specification of the ISZ-650 gyroscope conforms to Moisture Sensitivity Level (MSL) 3, as defined by IPC/JEDEC J-STD-020D.01.

Storage Specifications for ISZ-650

Calculated shelf-life in moisture-sealed bag	12 months -- Storage conditions: <40°C and <90% RH
After opening moisture-sealed bag	168 hours -- Storage conditions: ambient ≤30°C at 60% RH

10. Reliability

10.1 Qualification Test Policy

InvenSense's products complete a Qualification Test Plan before being released to production. The Qualification Test Plan follows the JEDEC 47D Standards, "Stress-Test-Driven Qualification of Integrated Circuits," with the individual tests described below.

10.2 Qualification Test Plan

Accelerated Life Tests

Test	Method/Condition	Lot Quantity	Samples / Lot	Accept / Reject Criteria
High Temperature Operating Life (HTOL/LFR)	JEDEC JESD22-A108C, Dynamic, 3.63V biased, T _j >125°C [read-points 168, 500, 1000 hours]	3	77	(1/2)
Steady-State Temperature Humidity Unbiased Life ⁽¹⁾	JEDEC JESD22-A101C, 85°C/85%RH [read-points 168, 500, 1000 hours]	3	77	(1/2)
High Temperature Storage Life	JEDEC JESD22-A103C, Cond. A, 125°C Non-Bias Bake [read-points 168, 500, 1000 hours]	3	77	(1/2)

Device Component Level Tests

Test	Method/Condition	Lot Quantity	Samples / Lot	Accept / Reject Criteria
ESD-HBM	JEDEC JESD22-A114F, Class 2 (2KV)	1	15	(0/1)
ESD-MM	JEDEC JESD22-A115-A, Class B (200V)	1	12	(0/1)
Latch Up	JEDEC JESD78B Class 1 (25°C), Level 1 (+/- 100mA)	1	6	(0/1)
Mechanical Shock	JEDEC JESD22-B104C, Mil-Std-883, method 2002, Cond. D, 10,000g's, 0.3ms, ±X,Y,Z – 6 directions, 5 times/direction	3	5	(0/1)
Vibration	JEDEC JESD22-B103B, Variable Frequency (random), Cond. B, 5-500Hz, X,Y,Z – 4 times/direction	3	5	(0/1)
Temperature Cycling ⁽¹⁾	JEDEC JESD22-A104D Condition N, -40°C to +85°C, Soak Mode 2, 100 cycles	3	77	(1/2)

(1) Tests are preceded by MSL3 Preconditioning in accordance with JEDEC JESD22-A113F

	ISZ-650 Single-Axis Z-Gyroscope Product Specification	PS-ISZ-0650B-00-02 Release Date: 07/08/09
---	--	--

11. Environmental Compliance

The ISZ-650 gyroscope is RoHS and Green compliant.

Assembler: Lingsen Precision Industries, Inc.
Package Type: QFN 28L 4x5x1.2mm
Package Total Mass (mg): 61.25

Component	Substance	CAS Number	Percent (%)	Material Weight (mg)	Amount of Substance (mg)
-----------	-----------	------------	-------------	----------------------	--------------------------

Semiconductor Device

Silicon Chip	Doped Silicon (Si)	7440-21-3	100	6.94	6.94
--------------	--------------------	-----------	-----	------	------

Lead Frame (ASM 28N C7025AG, with JAU JANQ Matte Sn Finish)

Base Metal	Copper (Cu)	7440-50-8	Balance	10.32	9.964
Base Metal	Iron (Fe)	7439-89-6	2.1-2.6		0.227
Base Metal	Phosphorus (P)	7723-14-0	0.015-0.15		0.009
Base Metal	Zinc (Zn)	7440-66-6	0.05-0.20		0.013
Finish Plating	Matte Tin (Sn)	7440-31-5	1.04		0.107

Bond Wire (Sumitomo Metal Mining 1.0MIL (2KM) SGL-2 Gold Wire)

Gold Metal	Gold (Au)	7440-57-5	>99.99	1.12	1.120
------------	-----------	-----------	--------	------	-------

Die Attach Adhesive (Henkel Ablebond 2025D)

Filler	Dimethyl Siloxane, Dimethylvinylsiloxy-Terminated	068083-19-2	Balance	0.78	0.679
Filler	Trimethylated Silica	068909-20-6	7-13		0.078
Filler	Dimethyl, Methylhydrogen Siloxane, Hydrogen-Terminated	069013-23-6	1-5		0.023

Mold Compound (Sumitomo Bakelite GREEN EME-G770H)

Filler	Epoxy Resin-1	Trade Secret	2-5	42.14	1.475
Filler	Epoxy Resin-2	Trade Secret	1-3		0.843
Filler	Phenol Resin	Trade Secret	2-5		1.475
Hardener	Silica	60676-86-0	Balance		33.84
Coloring Material	Carbon Black	1333-86-4	Approx. 0.2		0.084
Filler	Metal Hydroxide	Trade Secret	1-10		2.318
-	Others	-	Max. 5		2.107

Test results for RoHS banned substances/compounds:

Substance/Compound	Test Method	Die	Lead-frame	Bond Wire	Die Attach Adhesive	Mold Compound
Hexavalent Chromium	EPA3060A/ 7196A	Not Available	ND(<5)	ND(<2)	ND(<1)	ND (<2)
Cadmium	EN1122 Method B:2001	Not Available	ND(<5)	ND(<2)	ND(<2)	ND (<2)
Mercury	US EPA 3052	Not Available	ND(<5)	ND(<2)	ND(<2)	ND (<2)
Lead	US EPA 3050B	Not Available	ND(<10)	ND(<2)	ND(<2)	ND (<2)
PBBs	EPA3540B/ 3550B	Not Available	ND(<250)	ND(<5)	ND(<5)	ND(<5)
PBDEs	EPA3540B/ 3550B	Not Available	ND(<250)	ND(<5)	ND(<5)	ND(<5)

ND = Not Detected

Environmental Declaration Disclaimer:

InvenSense believes this environmental information to be correct but cannot guarantee accuracy or completeness. Conformity documents for the above component are on file. InvenSense subcontracts manufacturing and the information contained herein is based on data received from vendors and suppliers. This information has not been validated by InvenSense.



**ISZ-650 Single-Axis Z-Gyroscope
Product Specification**

PS-ISZ-0650B-00-02
Release Date: 07/08/09

This information furnished by InvenSense is believed to be accurate and reliable. However, no responsibility is assumed by InvenSense for its use, or for any infringements of patents or other rights of third parties that may result from its use. Specifications are subject to change without notice. InvenSense reserves the right to make changes to this product, including its circuits and software, in order to improve its design and/or performance, without prior notice. InvenSense makes no warranties, neither expressed nor implied, regarding the information and specifications contained in this document. InvenSense assumes no responsibility for any claims or damages arising from information contained in this document, or from the use of products and services detailed therein. This includes, but is not limited to, claims or damages based on the infringement of patents, copyrights, mask work and/or other intellectual property rights.

Certain intellectual property owned by InvenSense and described in this document is patent protected. No license is granted by implication or otherwise under any patent or patent rights of InvenSense. This publication supersedes and replaces all information previously supplied. Trademarks that are registered trademarks are the property of their respective companies. InvenSense sensors should not be used or sold in the development, storage, production or utilization of any conventional or mass-destructive weapons or for any other weapons or life threatening applications, as well as in any other life critical applications such as medical equipment, transportation, aerospace and nuclear instruments, undersea equipment, power plant equipment, disaster prevention and crime prevention equipment.

InvenSense™ is a registered trademark of InvenSense, Inc. ISZ™ and ISZ-650™ are trademarks of InvenSense, Inc.

©2009 InvenSense, Inc. All rights reserved.