

Typical Applications

- Remote Keyless Entry (RKE)
- Remote Lighting Controls
- On-Site Paging
- Asset Tracking
- Wireless Alarm and Security Systems
- Long Range RFID
- Automated Resource Management

Features

- 315/418/433.92 MHz versions
- Low Cost
- 1.5-12V operation
- 5mA current consumption at 3V
- Small size.
- 0dBm output power at 3V
- 4800 baud operation

Description

The RCT-433-AS is ideal for remote control applications where low cost and longer range are required. The transmitter operates from a 1.5-12V supply, making it ideal for battery-powered applications. The transmitter employs a SAW-stabilized oscillator, ensuring accurate frequency control for best range performance. Output power and harmonic emissions are easy to control, making FCC and ETSI compliance easy. The manufacturing-friendly SMT style package and low-cost make the RCT-433-AS suitable for high volume applications. The RCT-433-ASB is suitable for IR reflow ovens and hot air soldering.



RCT-433-AS



RCT-433-ASB

Ordering Information

Frequency	Part Number
433.92 MHz	RCT-433-AS
433.92 MHz	RCT-433-ASB

Domestic and international orders:

Mouser Electronics 1-800-346-6873 (<http://www.mouser.com>)
Future Electronics (<http://www.futureelectronics.com>)

For a Radiotronics Representative in your area please visit www.radiotronics.com and visit our corporate information page.

Document Control

Created By	Steve Montgomery	05/21/02
Engineering Review	Tom Marks	8/21/03
Marketing Review	Bryan Montgomery	8/21/03
Approved - Engineering	Tom Marks	8/21/03
Approved - Marketing	Bryan Montgomery	8/21/03

Revision History

Revision	Author	Date	Description
1.1.0	SJM	05/21/02	Document Created
1.2.0	BFA	07/30/03	Revision
1.3.0	SJM	8/21/03	Revision. Added troubleshooting and design tips.
1.4.0	GWH	6/7/05	Added RCT-433-ASB specification to datasheet.

Pin Out Diagram

Pin Description

Pin No.	Pin Name	Description
1	ANT	50 ohm antenna output. The antenna port impedance affects output power and harmonic emissions. An L-C low-pass filter may be needed to sufficiently filter harmonic emissions.
2	GND	Transmitter ground. Connect to ground plane.
3	DATA	Digital data input. This input is CMOS compatible and should be driven with CMOS level inputs.
4	VCC	Pin 4 provides operating voltage for the transmitter. VCC should be bypassed with a .01uF ceramic capacitor and filtered with a 4.7uF tantalum capacitor. Noise on the power supply will degrade transmitter noise performance.

Mechanical Drawing

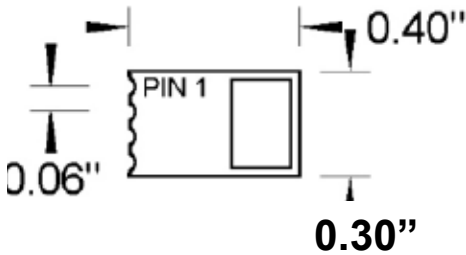

Figure 1: Mechanical Drawing of RCT-433-AS

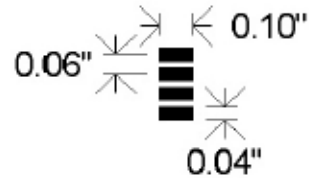

Figure 2: Suggested Pad Layout

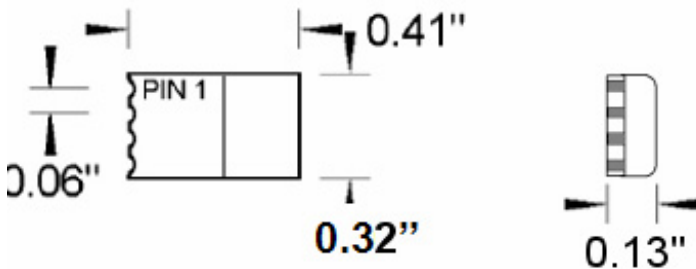

Figure 3: Mechanical Drawing of RCT-433-ASB

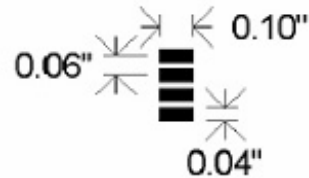

Figure 4: Suggested Pad Layout

RCT-433-ASB Reflow Details

The RCT-433-ASB is suitable for reflow ovens and heat guns. To prevent damage to the module through excess heat, the reflow oven temperature profiling is very important. A suggested oven profile is detailed in figure 5 below.

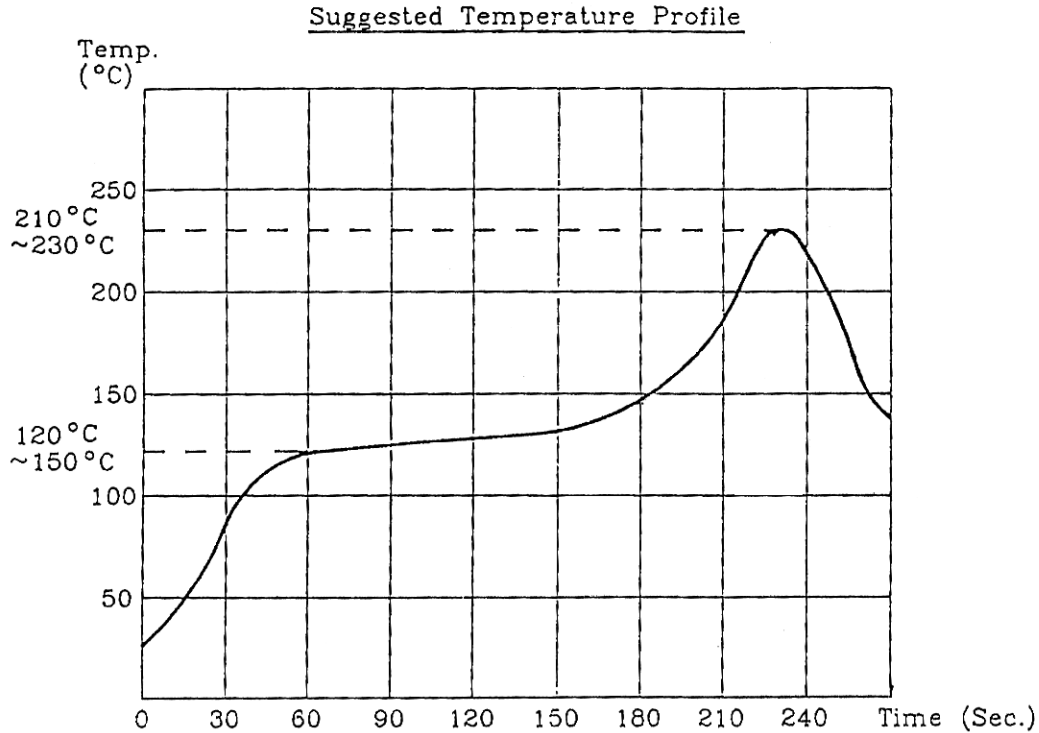

Figure 5: RCT-433-ASB Reflow Oven Temperature Profile

Absolute Maximum Ratings

Parameter	Min	Max	Units
Power Supply and All Input Pins	-0.3	+15	VDC
Storage Temperature	-50	100	°C
Soldering Temperature (10sec) ₁	NA	350	°C

NOTES 1) The RCT-433-AS is hand solder only. The Transmitter is not suitable for IR reflow or hot air soldering. The RCT-433-ASB is suitable for IR reflow and hot air soldering.

Detailed Electrical Specifications

Parameter (General)	Symbol	Min	Typ.	Max	Units	Notes
Operating Voltage	V_{cc}	1.5	3.0	12	Volts DC	
Operating Current DATA=VCC	I_{cc}	---	4.5	---	mA	@3V
Operating Current DATA=GND	I_{cc}	---	100	---	uA	@3V
Frequency Accuracy	TOL_{fc}	-75	0	+75	Khz	@3V
Center Frequency	F_c	---	315.0 418.0 433.92	---	MHz	RCT-315-AS RCT-418-AS RCT-433-AS
Output Power		---	0		dBm	@3V
Baud Rate – NRZ		DC	---	4800	BPS	

Theory of Operation

OOK Modulation

OOK modulation is a binary form of amplitude modulation. When a logical 0 (data line low) is being sent, the transmitter is off, fully suppressing the carrier. In this state, the transmitter current is very low, less than 1mA.

When a logical 1 is being sent, the carrier is fully on. In this state, the module current consumption is at its highest, about 4.5mA with a 3V power supply.

OOK is the modulation method of choice for remote control applications where power consumption and cost are the primary factors. Because OOK transmitters draw no power when they transmit a 0, they exhibit significantly better power consumption than FSK transmitters.

OOK data rate is limited by the start-up time of the oscillator. High-Q oscillators which have very stable center frequencies take longer to start-up than low-Q oscillators. The start-up time of the oscillator determines the maximum data rate that the transmitter can send.

DESIGN HINT “Using the RCT-433-AS with a microcontroller UART”: Data should be inverted when using the transmitter with a UART. The normal marking state of a UART is a logic 1, which will cause constant transmission. By inverting the data, the transmitter will be off in a marking state and on in a spacing state (logical 0), ensuring that the transmitter is on only when data is being sent. The output of the receiver would also need to be inverted to properly recover data.

SAW stabilized oscillator

The transmitter is basically a negative resistance LC oscillator whose center frequency is tightly controlled by a SAW resonator. SAW (Surface Acoustic Wave) resonators are fundamental frequency devices that resonate at frequencies much higher than crystals.

The output of the oscillator is derived directly from the collector of the oscillator transistor. It is, therefore, very sensitive to VSWR. The module is designed to work with a 50 ohm load, which exhibits a VSWR of 1. The designer must ensure that the antenna exhibits no more than a VSWR of 2 to guarantee operation. This is particularly true for PCB trace antennas. If the module does not appear to have any output at the antenna port, it is likely that the antenna does not meet this requirement.

TROUBLESHOOTING HINT:

If the module appears to have no output at the antenna port, try the following: disconnect the antenna and put a 1000pF cap in series with a 51 ohm resistor to ground. This will ensure that the transmitter is properly loaded. Then look at the output with a scope and you should see the oscillator working. If it is working, the antenna is not properly tuned and that is the reason that the module is not working properly. If not, then check the power supply and data input for proper voltage levels.

Data Rate

The oscillator start-up time is on the order of 40uSec, which limits the maximum data rate to 4.8 kbit/sec.

TROUBLESHOOTING HINT:

If the module appears to have a good output, but your data rate is corrupted, that could be a sign that the start-up time of the oscillator is too long. The load on the antenna affects oscillator start-up time. To determine the start-up time of the oscillator, use a 2 channel digital storage oscilloscope. Attach channel 1 to the data input and channel 2 to the antenna output (don't worry, it won't affect the antenna VSWR). Trigger the scope on a rising edge on channel 1. Now, toggle the data pin from low to high and capture the resulting waveform. You should see a square edge on channel 1 and the oscillator ring-up on channel 2. Measure the time between the rising edge on channel 1 and when the oscillator waveform is at its full voltage swing, and you have the start-up time. To determine if the antenna is the problem, remove it and place a 1000pF cap in series with a 51-ohm resistor to ground and repeat the test. If the start-up time is correct with the test load, the problem is the antenna.

Power Supply

The RCT-433-AS is designed to operate from a 1.5 -12V power supply. It is crucial that this power supply be very quiet. The power supply should be bypassed using a 0.01uF low-ESR ceramic capacitor and a 4.7uF ceramic capacitor. These capacitors should be placed as close to the power pins as possible.

Antenna Output

Pin 1 is a 50 ohm antenna output. It will support most antenna types, including printed antennas integrated directly onto the PCB. The performance of the different antennas varies. There are many good application notes available that describe external and PCB trace antennas. We maintain a list in the technical support section of our website.

DESIGN HINT “Antenna traces”:

Any time a trace is longer than $1/8^{\text{th}}$ the wavelength of the frequency it is carrying, it should be a 50 ohm micro strip. This ensures that a proper match is maintained between the transmitter output and the antenna.

DESIGN HINT “Harmonic Filter”:

The impedance at the antenna power affects the VSWR, power output, and harmonic output of the transmitter. In most cases, the output of the transmitter may need a low-pass LC filter to reduce harmonic emissions. A good calculator is available on line at <http://www-users.cs.york.ac.uk/~fisher/lcfilter/>. Calculate the filter for a 3dB cut-off of the module’s center frequency plus 10%. For example, the cut-off for a 433.92 MHz module would be about 470 MHz.

DESIGN HINT “T-Pad”:

The RCT-433-AS transmitter can be sensitive to unbalanced or unmatched loads and could fail to operate or operate intermittently in this condition. Try to match your antenna load as close to 50 ohms as possible. Use a T-pad if necessary to give the transmitter a close 50 ohm match before your antenna. A T-pad will also act as an attenuator. See figure 6 below, for a T-pad match/attenuator circuit.

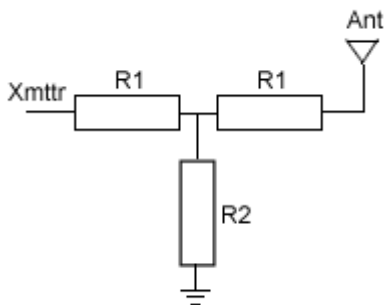

Figure 6: T-pad Example.

Resistor values in this T-pad example are:

R1 - 10 ohms.

R3 - 150 ohms.

Contact Information

Address: 207 Industrial Blvd
Moore, Oklahoma 73160

Phone: 405-794-7730
Fax: 405-794-7477
www: www.radiotronix.com
sales: sales@radiotronix.com

Technical Support Policy

Radiotronix has built a solid technical support infrastructure so that you can get answers to your questions when you need them.

Our primary technical support tools are the support forum and knowledge base found on our website. We are continuously updating these tools. To find the latest information about these technical support tools, please visit <http://www.radiotronix.com/support/>

Our technical support engineers are available Mon-Fri between 9:30 am and 4:30 pm central standard time. The best way to reach a technical support engineer is to send an email by visiting the Support page at <http://www.radiotronix.com/support/>. E-mail support requests are given priority because we can handle them more efficiently than phone support requests.

For customers that would prefer to talk directly to a support engineer, we do offer phone support free of charge. All support requests are placed in a queue and returned in the order that they are received.