

8 - 15 GHz Doubler with Amplifier

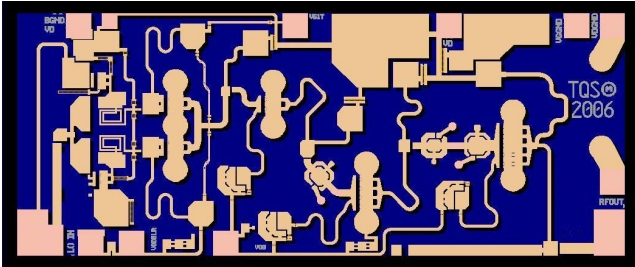

Key Features

- RF Output Frequency Range: 16-30 GHz
- Input Frequency Range: 8 - 15 GHz
- 22 dBm Nominal Pout
- 20 dB Gain
- 10 dBc Input Frequency Isolation
- Bias: Vd = 5 V, Id = 150 mA, Vg = -0.5 V Typical
- Technology: 3MI 0.25 um Power PHEMT
- Chip Dimensions: 2.068 x 0.88 x 0.1 mm

Measured Performance

Bias conditions: Vd = 5 V, Id = 150 mA, Vdbl = -0.8 V, Vg = -0.5 V Typical

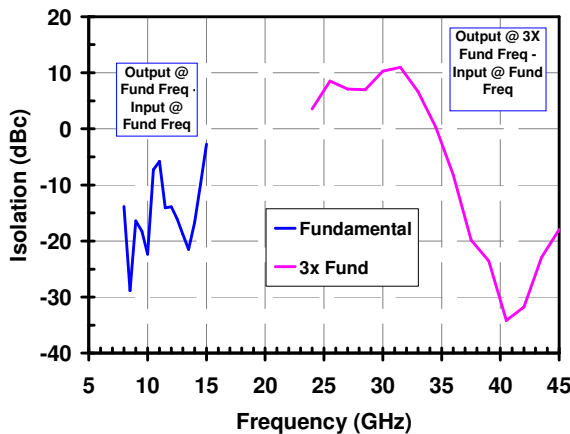
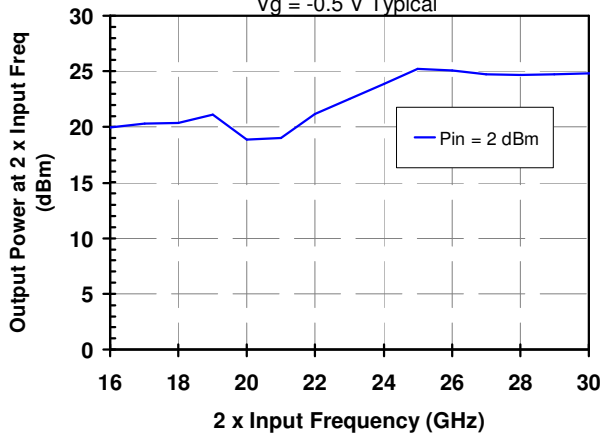

Primary Applications

- Point-to-Point Radio
- Ka Band Sat-Com

Product Description

The TriQuint TGC4403 MMIC combines a frequency doubler with a 3-stage amplifier, operating at input frequencies of 8 - 15 GHz. With greater than 30 dBc suppression measured at the output between the input frequency and doubled frequency, the TGC4403 achieves 22 dBm output power, with 2 dBm input power. This performance makes this doubler ideally suited for Point to Point Radios and Ka Band satellite ground terminal applications. The TGC4403 utilizes TriQuint's robust 0.25um power pHEMT process coupled with 3 layer Metal Inteconnect (3MI) technology. The TGC4403 provides the frequency doubling function in an extremely compact (< 1.8 mm²) chip footprint.

Each device is 100% DC and RF tested on-wafer to ensure performance compliance. The device is available in chip form.

The TGC4403 has a protective surface passivation layer providing environmental robustness.

Lead-free and RoHS compliant.

Datasheet subject to change without notice.

Table I
Absolute Maximum Ratings 1/

Symbol	Parameter	Value	Notes
Vd-Vg	Drain to Gate Voltage	12 V	
Vd	Drain Voltage	8 V	2/
Vdbl	Doubler Voltage Range	-5 to 0 V	
Vg	Gate Voltage Range	-5 to 0 V	
Id	Positive Current	280 mA	2/
Ig	Gate Current Range	-1 to 23.mA	
Idbl	Doubler Current Range	-0.6 to 16.8 mA	
Pin	Input Continuous Wave Power	18.2 dBm	2/

- 1/ These ratings represent the maximum operable values for this device. Stresses beyond those listed under "Absolute Maximum Ratings" may cause permanent damage to the device and / or affect device lifetime. These are stress ratings only, and functional operation of the device at these conditions is not implied.
- 2/ Combinations of supply voltage, supply current, input power, and output power shall not exceed the maximum power dissipation listed in Table IV.

Table II
Recommended Operating Conditions

Symbol	Parameter 1/	Value
Vd	Drain Voltage	5 V
Id	Drain Current (quiescent)	150 mA
Id_drive	Drain Current with RF input = 2 dBm	170 mA
Vg	Gate Voltage	-0.5 V
Vdbl	Doubler Voltage	-0.8 V

- 1/ See assembly diagram for bias instructions.

Table III
RF Characterization Table

Bias: Vd = 5 V, Id = 150 mA, Vg = -0.5 V, Vdbl = -0.8 V Typical

SYMBOL	PARAMETER	TEST CONDITIONS	MIN	NOMINAL	MAX	UNITS
RF_Freq	Input Frequency Range		8	-	15	GHz
Gain	Conversion Gain	f = 16 GHz	-	17	-	dB
		f = 18 - 22 GHz	14	18	-	
		f = 24 GHz	19	21	-	
		f = 26 - 28 GHz	21	24	-	
		f = 30 GHz	-	20	-	
IRL	Input Return Loss	f = 16 - 30 GHz	-	7	-	dB
ORL	Output Return Loss	f = 16 - 30 GHz	-	7	-	dB
Pout	Output Power (RFin = 2 dBm)	f = 16 GHz	-	20	-	dBm
		f = 18 - 20 GHz	16	20	-	
		f = 22 GHz	21	26	-	
		f = 24 - 28 GHz	23	26	-	
		f = 30 GHz	-	22	-	
Isol	Isolation	f = 16 - 28 GHz	0	10	-	dBc

Table IV
Power Dissipation and Thermal Properties

Parameter	Test Conditions	Value	Notes
Maximum Power Dissipation	Tbaseplate = 70 °C	Pd = 1.42 W Tchannel = 150 °C Tm = 1.0E+6 Hrs	1/ 2/
Thermal Resistance, θ_{jc}	Vd = 5 V Id = 150 mA Pd = 0.75 W	θ_{jc} = 56.3 (°C/W) Tchannel = 112 °C Tm = 3.4E+7 Hrs	
Thermal Resistance, θ_{jc} Under RF Drive	Vd = 5 V Id = 170 mA Pout = 22 dBm Pd = 0.69 W	θ_{jc} = 56.3 (°C/W) Tchannel = 109 °C Tm = 4.6E+7 Hrs	
Mounting Temperature	30 Seconds	320 °C	
Storage Temperature		-65 to 150 °C	

- 1/ For a median life of 1E+6 hours, Power Dissipation is limited to

$$Pd(max) = (150\text{ °C} - Tbase\text{ °C})/\theta_{jc}.$$
- 2/ Channel operating temperature will directly affect the device median time to failure (MTTF). For maximum life, it is recommended that channel temperatures be maintained at the lowest possible levels.

Power De-rating Curve

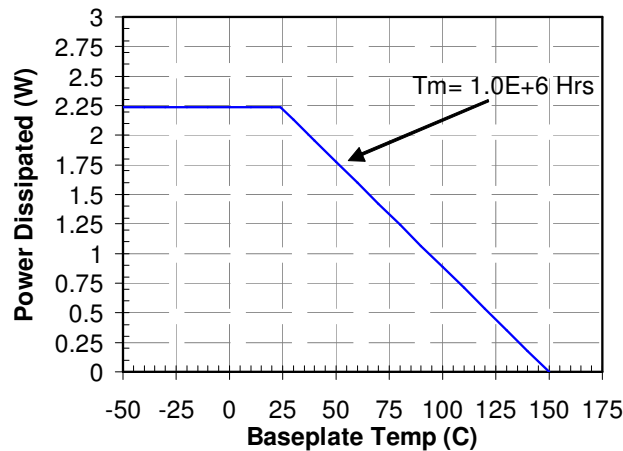

Measured Data

Bias conditions: $V_d = 5\text{ V}$, $I_d = 150\text{ mA}$, $V_{dbl} = -0.8\text{ V}$, $V_g = -0.5\text{ V}$ Typical

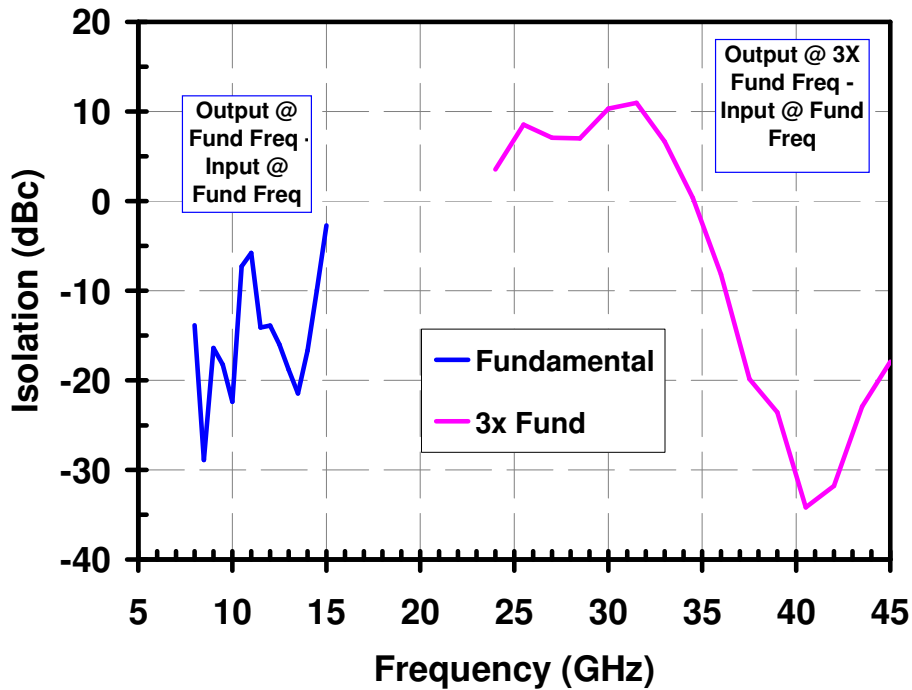
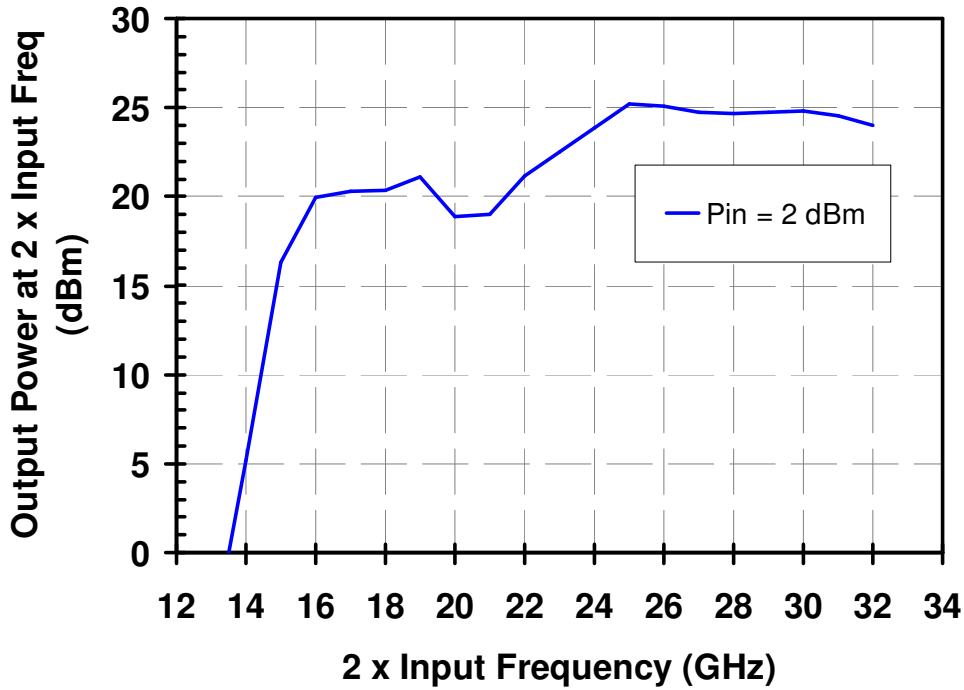

Measured Data

Bias conditions: $V_d = 5\text{ V}$, $I_d = 150\text{ mA}$, $V_{dbl} = -0.8\text{ V}$, $V_g = -0.5\text{ V}$ Typical

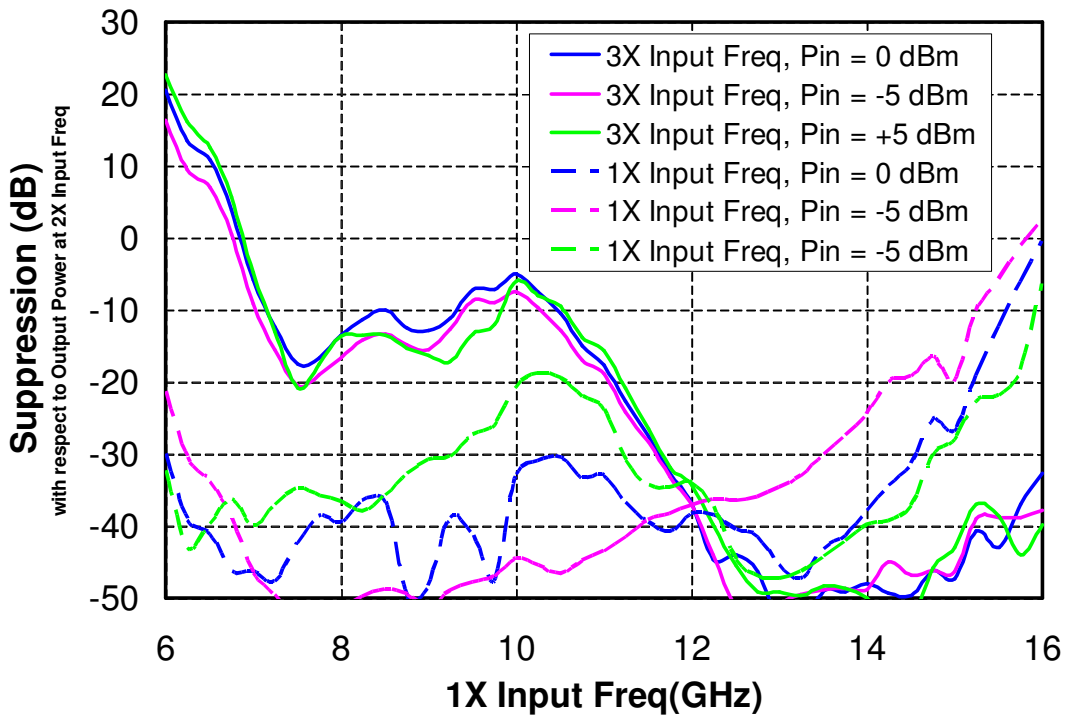
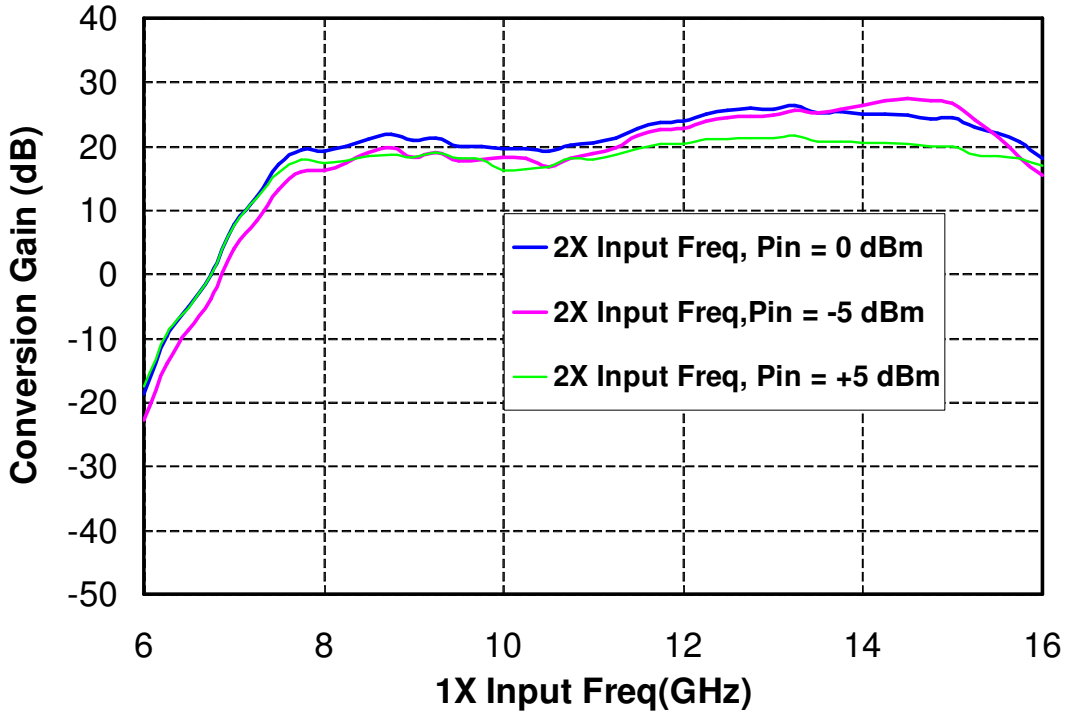

Measured Data

Bias conditions: $V_d = 5\text{ V}$, $I_d = 150\text{ mA}$, $V_{dbl} = -0.8\text{ V}$, $V_g = -0.5\text{ V}$ Typical

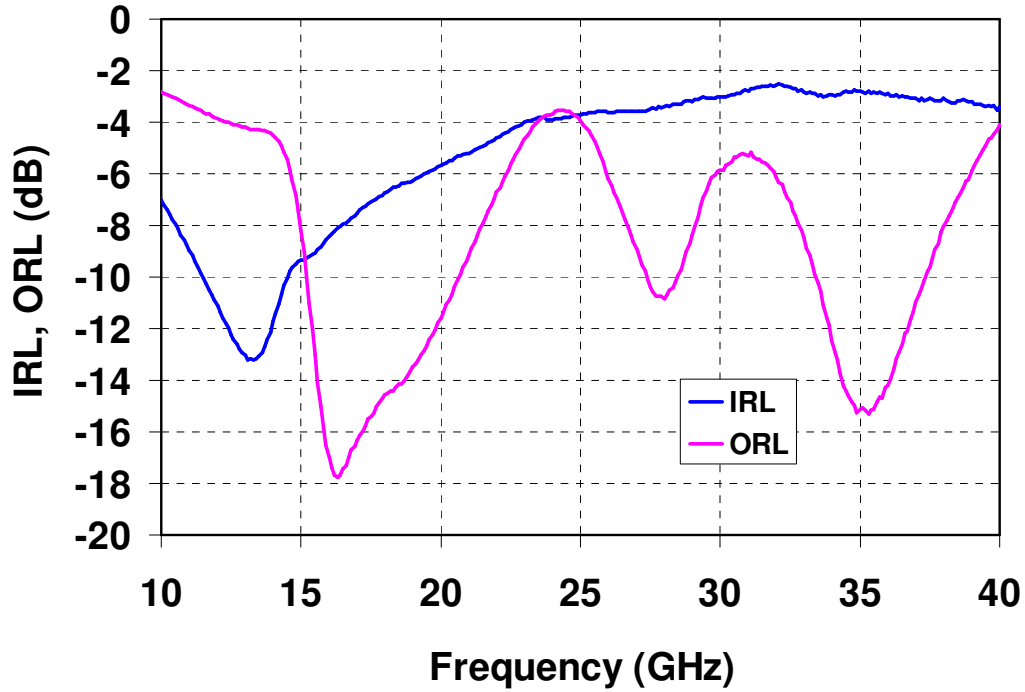

Electrical Schematic

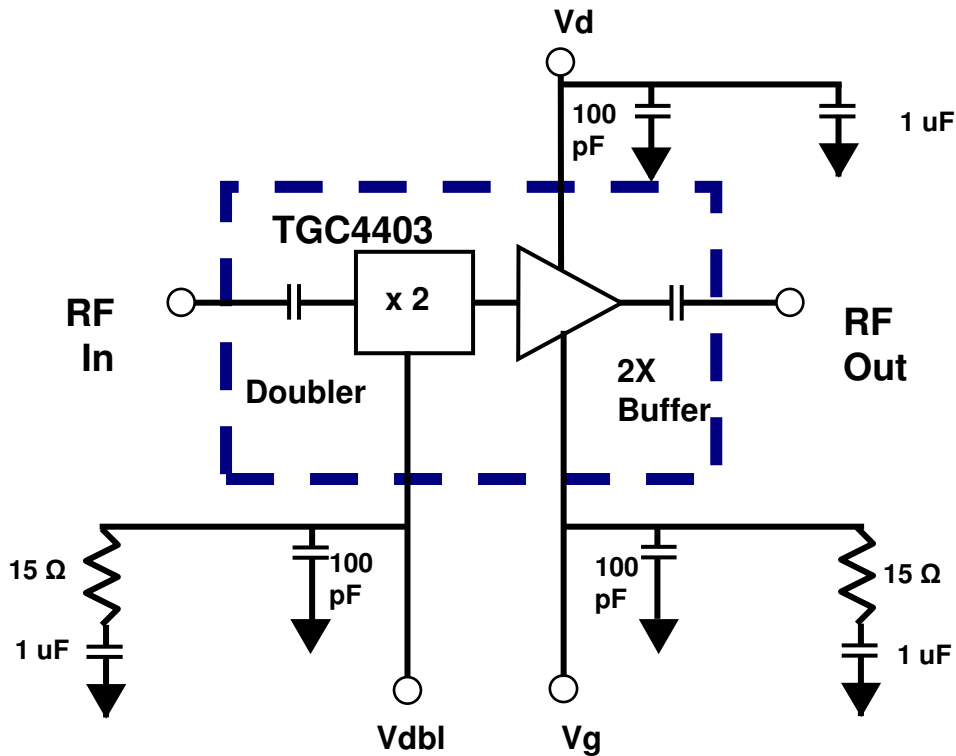

Bias Procedures

Bias-up Procedure

- Vg set to -1.5 V
- Vd set to +5 V
- Vdbl set to -0.8 V
- Adjust Vg more positive until Id is 150 mA. This will be ~ Vg = -0.5 V
- Apply signal to input, Id will increase

Bias-down Procedure

- Turn off signal
- Reduce Vg to -1.5V. Ensure Id ~ 0 mA
- Turn Vdbl to 0V
- Turn Vd to 0V
- Turn Vg to 0V

Mechanical Drawing

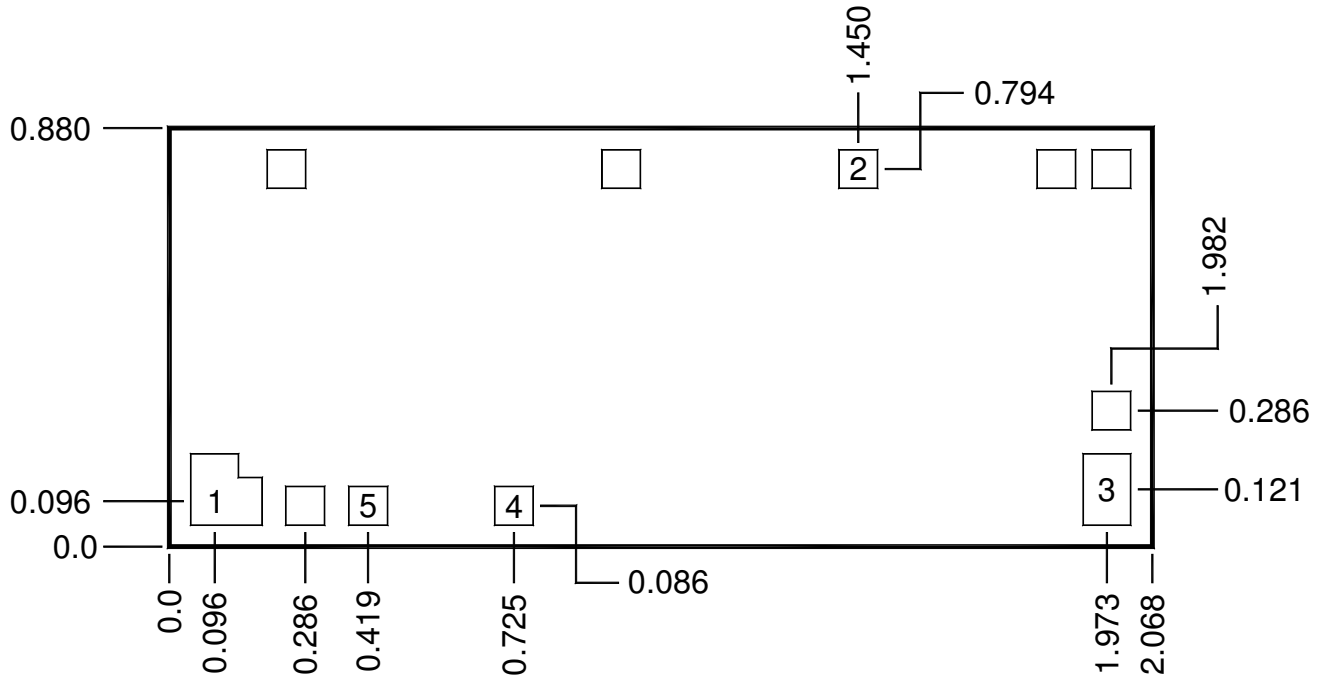

Units: millimeters

Thickness: 0.10

Die x,y size tolerance: +/- 0.050

Chip edge to bond pad dimensions are shown to center of pad

Ground is backside of die

Bond Pad #1	RF In	0.100 x 0.100
Bond Pad #2	Vd	0.081 x 0.081
Bond Pad #3	RF Out	0.100 x 0.150
Bond Pad #4	Vg	0.081 x 0.081
Bond Pad #5	Vdbl	0.081 x 0.081

GaAs MMIC devices are susceptible to damage from Electrostatic Discharge. Proper precautions should be observed during handling, assembly and test.

Recommended Assembly Diagram

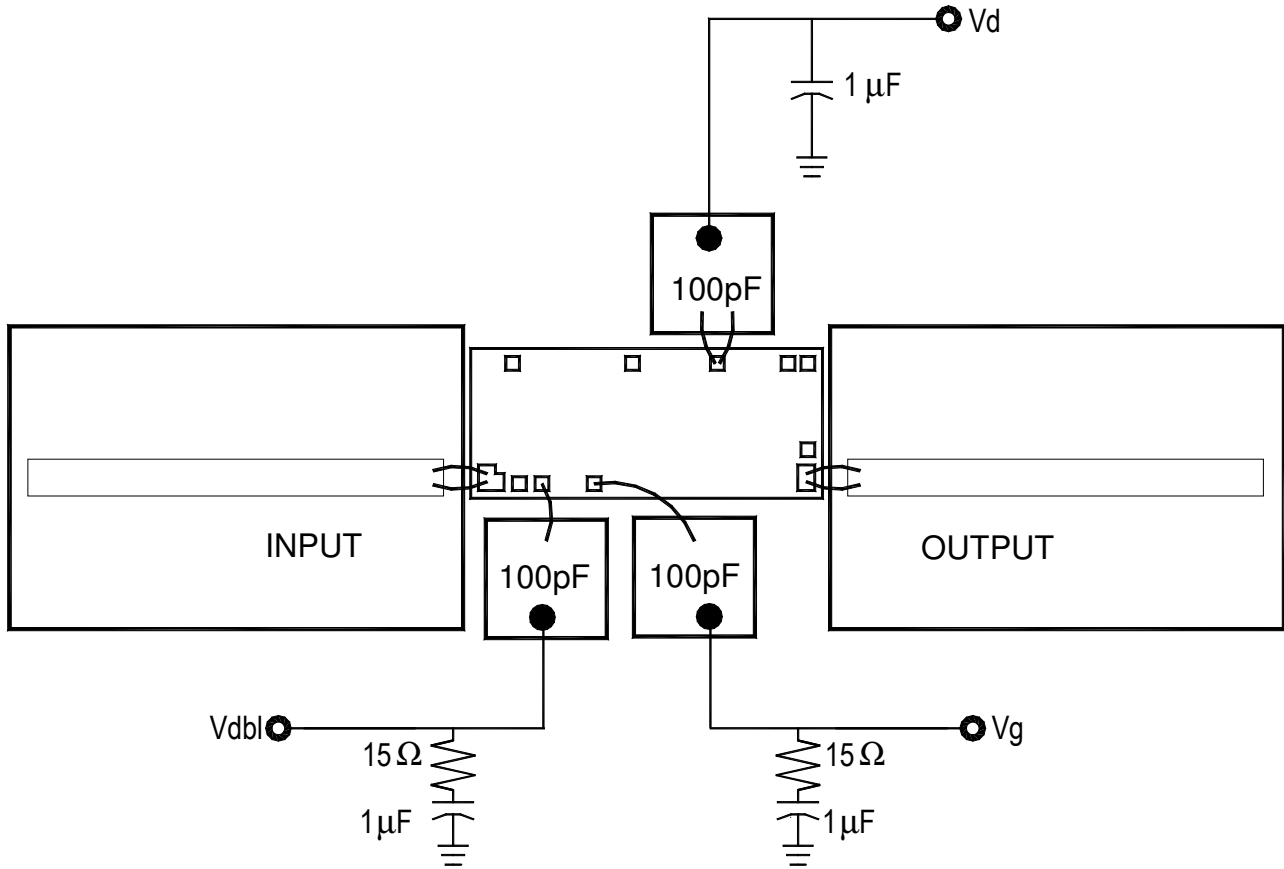

GaAs MMIC devices are susceptible to damage from Electrostatic Discharge. Proper precautions should be observed during handling, assembly and test.

Assembly Notes

Component placement and adhesive attachment assembly notes:

- Vacuum pencils and/or vacuum collets are the preferred method of pick up.
- Air bridges must be avoided during placement.
- The force impact is critical during auto placement.
- Organic attachment (i.e. epoxy) can be used in low-power applications.
- Curing should be done in a convection oven; proper exhaust is a safety concern.

Reflow process assembly notes:

- Use AuSn (80/20) solder and limit exposure to temperatures above 300°C to 3-4 minutes, maximum.
- An alloy station or conveyor furnace with reducing atmosphere should be used.
- Do not use any kind of flux.
- Coefficient of thermal expansion matching is critical for long-term reliability.
- Devices must be stored in a dry nitrogen atmosphere.

Interconnect process assembly notes:

- Thermosonic ball bonding is the preferred interconnect technique.
- Force, time, and ultrasonics are critical parameters.
- Aluminum wire should not be used.
- Devices with small pad sizes should be bonded with 0.0007-inch wire.

Ordering Information

Part	Package Style
TGC4403	GaAs MMIC Die

GaAs MMIC devices are susceptible to damage from Electrostatic Discharge. Proper precautions should be observed during handling, assembly and test.