



# CV111-1A

PCS/DCS-band High Linearity Downconverter



## Product Features

- High dynamic range downconverter with integrated LO, IF, & RF amps
- RF: 1710 – 2000 MHz
- IF: 65 – 250 MHz
- +38 dBm Output IP3
- +21 dBm Output P1dB
- 5.3 dB Noise Figure
- +5V Single supply operation
- Pb-free 6mm 28-pin QFN package
- Low-side LO configuration
- Common footprint with other UMTS/cellular versions

## Product Description

The CV111-1A is a high linearity downconverter designed to meet the demanding issues for performance, functionality, and cost goals of current and next generation mobile infrastructure basestations. It provides high dynamic range performance in a low profile surface-mount leadless package that measures 6 x 6 mm square.

Functionality includes RF amplification, frequency conversion and IF amplification, while an integrated LO driver amplifier powers the passive mixer. The MCM is implemented with reliable and mature GaAs MESFET and InGaP HBT technology.

Typical applications include frequency down conversion, modulation and demodulation for receivers used in CDMA/GSM/TDMA, CDMA2000, W-CDMA, GPRS, and EDGE 2.5G mobile infrastructure technologies for PCS / DCS frequency bands.

## Functional Diagram

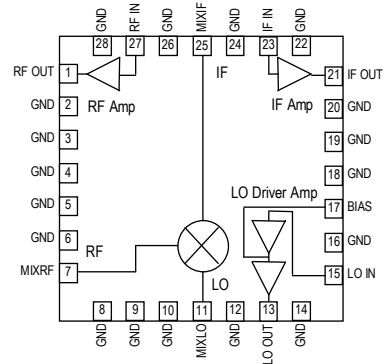

Top View

## Specifications <sup>(1)</sup>

| Parameters                             | Units              | Min  | Typ         | Max  | Comments                        |
|--|--------------------|------|-------------|------|---------------------------------|
| RF Frequency Range                     | MHz                |      | 1710 – 2000 |      |                                 |
| LO Frequency Range                     | MHz                |      | 1460 – 1935 |      |                                 |
| IF Center Frequency Range              | MHz                |      | 65 – 250    |      | See note 2                      |
| % Bandwidth around IF center frequency | %                  |      | ±7.5        |      | See note 3                      |
| IF Test Frequency                      | MHz                |      | 240         |      |                                 |
| SSB Conversion Gain                    | dB                 |      | 20          |      | Temp = 25 °C                    |
| Gain Drift over Temp (-40 to 85 °C)    | dB                 |      | ±1.5        |      | Referenced to +25 °C            |
| Output IP3                             | dBm                |      | +38         |      | See note 4                      |
| Output IP2                             | dBm                |      | +48         |      | See note 4                      |
| Output 1dB Compression Point           | dBm                |      | +21         |      |                                 |
| Noise Figure                           | dB                 |      | 5.3         |      | See note 5                      |
| LO Input Drive Level                   | dBm                | -2.5 | 0           | +2.5 |                                 |
| LO-RF Isolation                        | dB                 |      | 45          |      | See note 6                      |
| LO-IF Isolation                        | dB                 |      | 35          |      | P <sub>LO</sub> = 0 dBm         |
| Return Loss: RF Port                   | dB                 |      | 14          |      |                                 |
| Return Loss: LO Port                   | dB                 |      | 14          |      |                                 |
| Return Loss: IF Port                   | dB                 |      | 11          |      |                                 |
| Operating Supply Voltage               | V                  | +4.9 | +5          | +5.1 |                                 |
| Supply Current                         | mA                 | 290  | 360         | 480  |                                 |
| FIT Rating                             | failures / 1E9 hrs |      |             | 72.1 | @ 70° C ambient, 90% confidence |
| Thermal Resistance                     | °C / W             |      |             | 27   |                                 |
| Junction Temperature                   | °C                 |      |             | 160  | See note 7                      |

1. Specifications when using the application specific circuit (shown on page 3) with a low side LO = 0 dBm in a downconverting application over the operating case temperature range.
2. IF matching components affect the center IF frequency. Proper component values for other IF center frequencies can be found in the IF Amplifier Matching Table or by e-mailing to sjcapps@tqs.com.
3. The IF bandwidth of the converter is defined as 15% around any center frequency in its operating IF frequency range. The bandwidth is determined with external components. Specifications are valid around the total ±7.5% bandwidth, i.e. with a center frequency of 240 MHz, the specifications are valid from 240 ± 18 MHz.
4. Assumes the supply voltage = +5 V. OIP3 is measured with Δf = 1 MHz with IF<sub>out</sub> = 5 dBm / tone.
5. Assumes LO injection noise is filtered at the thermal noise floor, -174 dBm/Hz, at the RF, IF, and Image frequencies.
6. L-R Isolation is referenced to an LO injection of 0 dBm. The L-R performance shown also includes the isolation due to an external SAW filter between the RF amplifier and mixer.
7. The maximum junction temperature ensures a minimum MTTF rating of 1 million hours of usage.

## Absolute Maximum Rating

| Parameter                                 | Rating         |
|---|----------------|
| Storage Temperature                       | -55 to +125° C |
| DC Voltage                                | +6 V           |
| Max. Junction Temperature, T <sub>j</sub> | +160 °C        |
| RF Input (continuous)                     | +2 dBm         |

Operation of this device above any of these parameters may cause permanent damage.

## Ordering Information

| Part No.       | Description  |
|----------------|--|
| CV111-1AF      | PCS/DCS-band High Linearity Downconverter (lead-free/RoHS-compliant 6x6mm QFN package) |
| CV111-1APCB240 | Fully Assembled Eval. Board, IF = 240MHz   |

Standard T/R size = 500 pieces on a 7" reel.

Specifications and information are subject to change without notice



# CV111-1A

PCS/DCS-band High Linearity Downconverter



## Device Architecture / Application Circuit Information

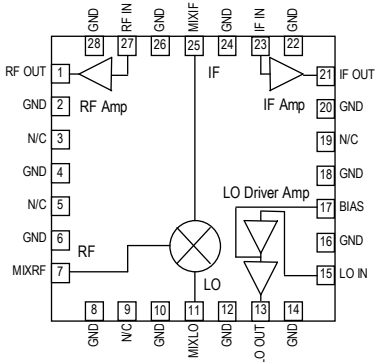

Typical Downconverter Performance Chain Analysis

| Stage               | Gain (dB)                     | Output P1dB (dBm) | Output IP3 (dBm) | NF (dB) | Current (mA) | Cumulative Performance |                   |                  |             |            |
|---------------------|-------------------------------|-------------------|------------------|---------|--------------|------------------------|-------------------|------------------|-------------|------------|
|                     |                               |                   |                  |         |              | Gain (dB)              | Output P1dB (dBm) | Output IP3 (dBm) | NF (dB)     |            |
| RF Amplifier        | 12                            | 21                | 41               | 3.5     | 140          | 12                     | 21.0              | 41.0             | 3.5         |            |
| RF Filter           | -2                            | ---               | ---              | 2.0     | ---          | 10                     | 19.0              | 39.0             | 3.6         |            |
| LO Amp / MMIC Mixer | -8.5                          | 8                 | 23               | 9.1     | 80           | 1.5                    | 6.1               | 22.2             | 4.8         |            |
| IF Amplifier        | 18.5                          | 23                | 41               | 2.1     | 140          | 20                     | 20.7              | 37.9             | 5.4         |            |
| <b>CV111-1A</b>     | <b>Cumulative Performance</b> |                   |                  |         |              | <b>360</b>             | <b>20</b>         | <b>20.7</b>      | <b>37.9</b> | <b>5.4</b> |

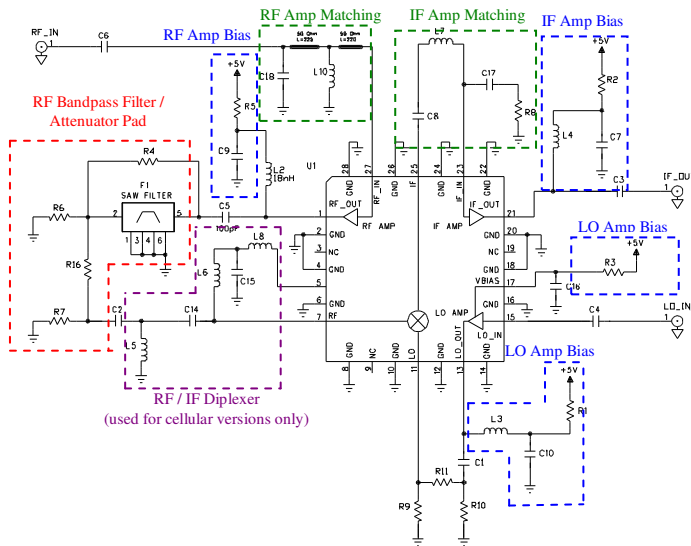

Printed Circuit Board Material:  
.014" FR-4, 4 layers, .062" total thickness

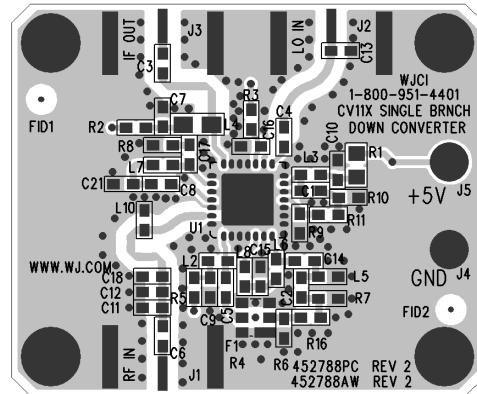

**CV111-1A:** The application circuit can be broken up into four main functions as denoted in the colored dotted areas above: RF/IF diplexing (purple; this is only used with the cellular-band CV products), amplifier matching (green), filtering (red), and dc biasing (blue). There are various placeholders for chip components in the circuit schematic so that a common PCB can be used for all WJ single-branch converters. Additional placeholders for other optional functions such as filtering are also included.

**RF / IF Amplifier Matching:** The RF amplifier requires a shunt matching element for optimal gain and input return loss performance. The IF amplifier requires matching elements to optimize the performance of the amplifier to the desired IF center frequency. Since IF bandwidths are typically on the order of 5 to 10%, a simple two element matching network, in the form of either a high-pass or low-pass filter structure, is sufficient to match the MMIC IF amplifier over these narrow bandwidths. Proper component values for other IF center frequencies can be found in the IF Amplifier Matching Table or by e-mailing to sjcapps@tqs.com.

**RF Bandpass Filtering:** Bandpass filtering is recommended to achieve the best noise figure performance with the downconverter. The bandpass filter, implemented with a SAW filter on the application circuit, allows for the suppression of noise from the image frequency. It is permissible to not use a filter and use a 2 dB pad with R6, R7, and R16 instead with slightly degraded noise figure performance.

**External Diplexer:** This is only used with the cellular-band CV products. The mixer performs the diplexing internally for the CV111-1A; therefore the components shown in the diplexer section should be loaded as follows: C2 = C14 = 0 Ω.

**DC biasing:** DC bias must be provided for the RF, LO and IF amplifiers in the converter. R1 sets the operating current for the last stage of the LO amplifier and is chosen to optimize the mixer LO drive level. Proper RF chokes and bypass capacitors are chosen for proper amplifier biasing at the intended frequency of operation. The "+5 V" dc bias should be supplied directly from a voltage regulator.

### IF Amplifier Matching

| Frequency (MHz)  | 40  | 50  | 75  | 100 | 125 | 130 | 155 | 169 | 180 | 210 | 240 |
|------------------|-----|-----|-----|-----|-----|-----|-----|-----|-----|-----|-----|
| <b>L7 (nH)</b>   | 470 | 430 | 150 | 150 | 120 | 120 | 100 | 82  | 82  | 82  | 56  |
| <b>C17 (pF)</b>  | 24  | 15  | 22  | 10  | 8.2 | 6.8 | 5.6 | 5.0 | 4.7 | 3.3 | 3.9 |
| <b>R8 (ohms)</b> | 4.7 | 4.7 | 3.3 | 2.2 | 2.2 | 2.2 | 2.2 | 2.2 | 2.2 | 2.2 | 2.2 |
| <b>L4 (nH)</b>   | 470 | 240 | 330 | 330 | 330 | 330 | 330 | 330 | 330 | 220 | 220 |

Specifications and information are subject to change without notice



# CV111-1A

PCS/DCS-band High Linearity Downconverter



## Downconverting Application Circuit: CV111-1APCB240 RF = 1800 – 2000 MHz, IF = 240 MHz

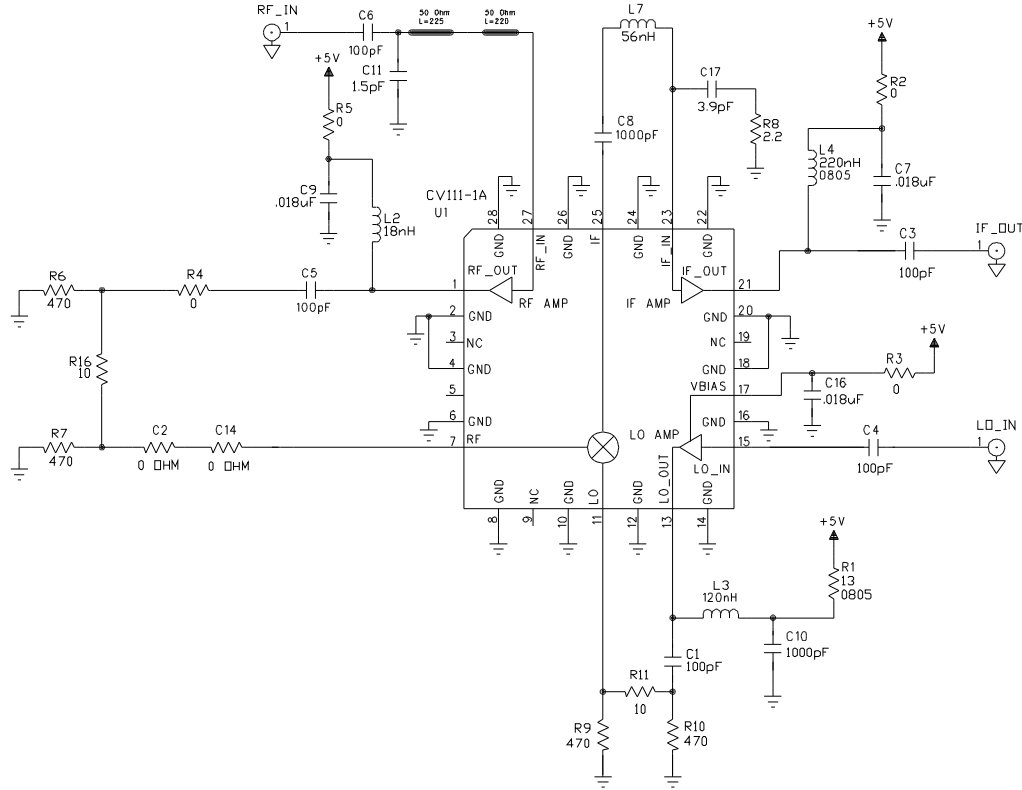

### PCB Layout

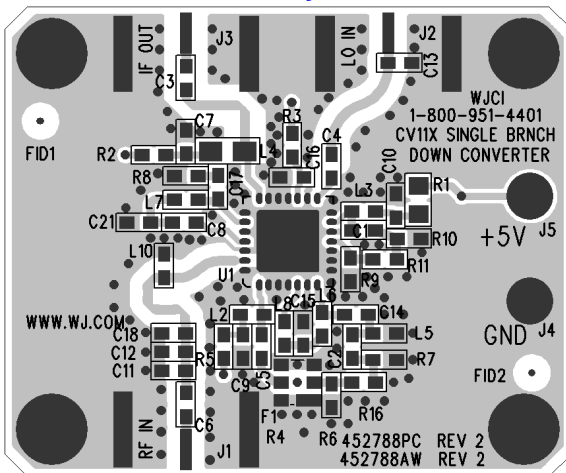

Circuit Board Material: .014" FR-4, 4 layers, .062" total thickness

### Bill of Materials

| Ref. Desig.                                  | Component  |
|--|--|
| R1   | 13 $\Omega$ chip resistor, size 0805                 |
| R2, R3, R4, R5, C2, C14                      | 0 $\Omega$ chip resistor                             |
| R6, R7, R9, R10                              | 470 $\Omega$ chip resistor                           |
| R8   | 2.2 $\Omega$ chip resistor                           |
| R11, R16                                     | 10 $\Omega$ chip resistor                            |
| C1, C3, C4, C5, C6                           | 100 pF chip capacitor                                |
| C7, C9, C16                                  | 0.018 $\mu$ F chip capacitor                         |
| C8, C10                                      | 1000 pF chip capacitor                               |
| C11  | 1.5 pF chip capacitor                                |
| C18, C12, C13, C15, C21, F1, L5, L6, L8, L10 | Shown in silkscreen, but not used in actual circuit. |
| C17  | 3.9 pF chip capacitor                                |
| L2   | 18 nH chip inductor                                  |
| L3   | 120 nH chip inductor                                 |
| L4   | 220 nH chip inductor, size 0805                      |
| L7   | 56 nH chip inductor                                  |
| U1   | CV111-1A WJ Converter                                |

All components are of size 0603 unless otherwise specified.

Specifications and information are subject to change without notice



# CV111-1A

PCS/DCS-band High Linearity Downconverter



## CV111-1APCB240 Application Circuit Performance Plots RF = 1800 – 2000 MHz, IF = 240 MHz

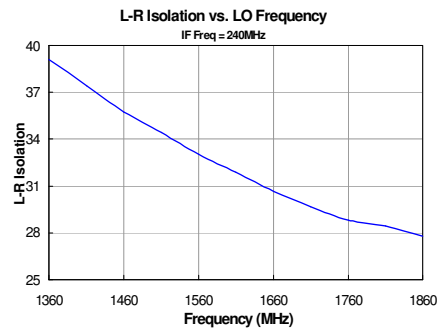
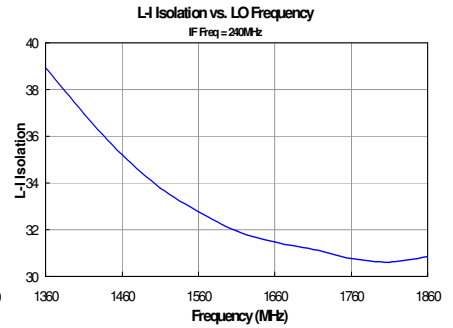
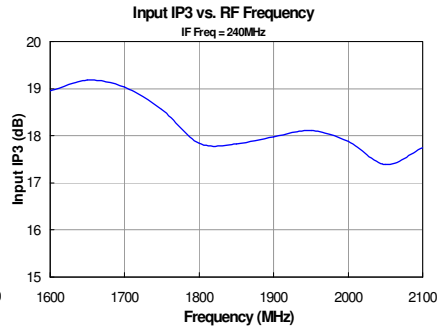
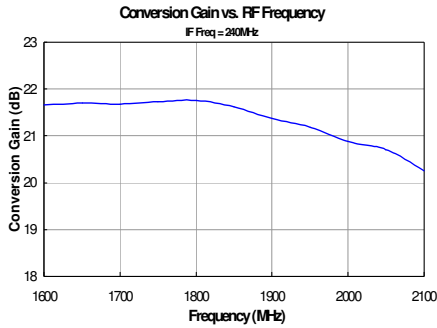



# CV111-1A

PCS/DCS-band High Linearity Downconverter



## Mechanical Information

This package is lead-free/RoHS-compliant. The plating material on the pins is annealed matte tin over copper. It is compatible with both lead-free (maximum 260 °C reflow temperature) and leaded (maximum 245 °C reflow temperature) soldering processes.

## Outline Drawing

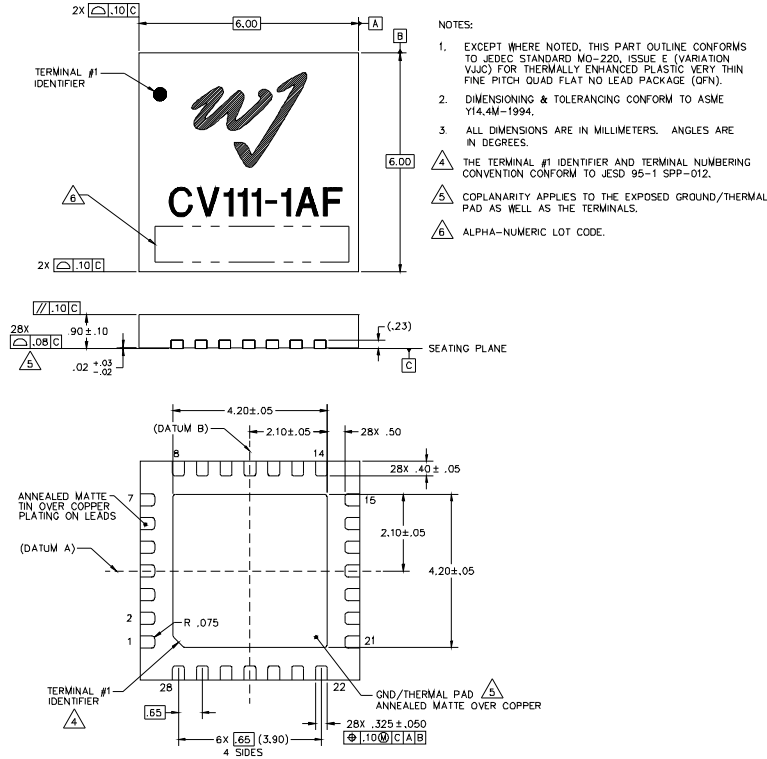

## Product Marking

The component will be lasermarked with a "CV111-1AF" product label with an alphanumeric lot code on the top surface of the package.

Tape and reel specifications for this part will be located on the website in the "Application Notes" section.

## ESD / MSL Information



Caution! ESD sensitive device.

ESD Rating: Class 1B  
 Value: Passes  $\geq 500V$  to  $<1000V$   
 Test: Human Body Model (HBM)  
 Standard: JEDEC Standard JESD22-A114

ESD Rating: Class III  
 Value: Passes  $\geq 500V$  to  $<1000V$   
 Test: Charged Device Model (CDM)  
 Standard: JEDEC Standard JESD22-C101

MSL Rating: Level 2 at +260 °C convection reflow  
 Standard: JEDEC Standard J-STD-020

## Mounting Configuration / Land Pattern

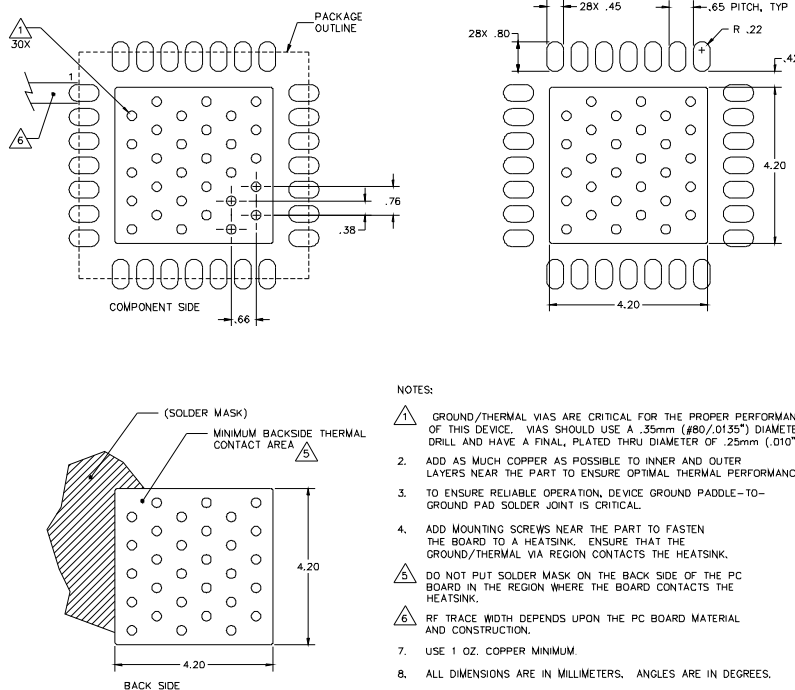

## Functional Pin Layout

| Pin | Function           | Pin | Function           |
|-----|--------------------|-----|--------------------|
| 1   | RF Amp Output      | 15  | LO Amp Input       |
| 2   | GND                | 16  | GND                |
| 3   | N/C or GND         | 17  | LO Amp Bias        |
| 4   | GND                | 18  | GND                |
| 5   | N/C or GND         | 19  | N/C or GND         |
| 6   | GND                | 20  | GND                |
| 7   | Mixer RF Input     | 21  | IF Amp Output/Bias |
| 8   | GND                | 22  | GND                |
| 9   | N/C or GND         | 23  | IF Amp Input       |
| 10  | GND                | 24  | GND                |
| 11  | Mixer LO Input     | 25  | Mixer IF Output    |
| 12  | GND                | 26  | GND                |
| 13  | LO Amp Output/Bias | 27  | RF Amp Input       |
| 14  | GND                | 28  | GND                |

Specifications and information are subject to change without notice