

## EVB-EMC2104/05 User Manual

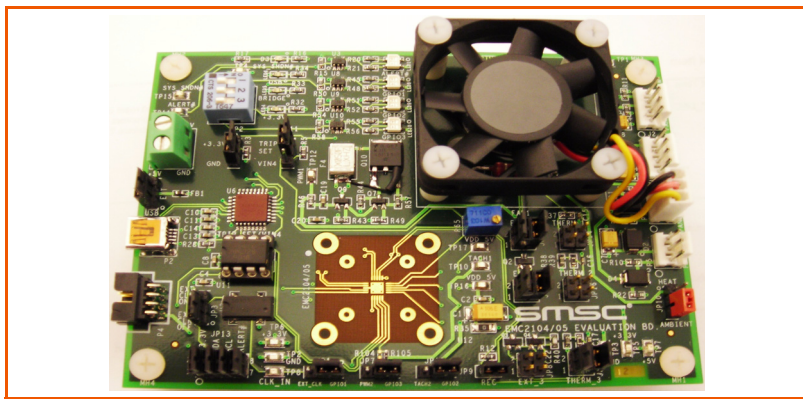

Copyright © 2007 SMSC or its subsidiaries. All rights reserved.

The information contained herein is proprietary to SMSC, shall be used solely in accordance with the agreement pursuant to which it is provided, and shall not be reproduced or disclosed to others without the prior written consent of SMSC. Although the information is believed to be accurate, no responsibility is assumed for inaccuracies. SMSC reserves the right to make changes to this document and to specifications and product descriptions at any time without notice. Neither the provision of this information nor the sale of the described semiconductor devices conveys any licenses under any patent rights or other intellectual property rights of SMSC or others. The product may contain design defects or errors known as anomalies, including but not necessarily limited to any which may be identified in this document, which may cause the product to deviate from published specifications. SMSC products are not designed, intended, authorized or warranted for use in any life support or other application where product failure could cause or contribute to personal injury or severe property damage. Any and all such uses without prior written approval of an officer of SMSC will be fully at the risk of the customer. SMSC is a registered trademark of Standard Microsystems Corporation ("SMSC").

SMSC DISCLAIMS AND EXCLUDES ANY AND ALL WARRANTIES, INCLUDING WITHOUT LIMITATION ANY AND ALL IMPLIED WARRANTIES OF MERCHANTABILITY, FITNESS FOR A PARTICULAR PURPOSE, TITLE, AND AGAINST INFRINGEMENT AND THE LIKE, AND ANY AND ALL WARRANTIES ARISING FROM ANY COURSE OF DEALING OR USAGE OF TRADE. IN NO EVENT SHALL SMSC BE LIABLE FOR ANY DIRECT, INCIDENTAL, INDIRECT, SPECIAL, PUNITIVE, OR CONSEQUENTIAL DAMAGES; OR FOR LOST DATA, PROFITS, SAVINGS OR REVENUES OF ANY KIND; REGARDLESS OF THE FORM OF ACTION, WHETHER BASED ON CONTRACT; TORT; NEGLIGENCE OF SMSC OR OTHERS; STRICT LIABILITY; BREACH OF WARRANTY; OR OTHERWISE; WHETHER OR NOT ANY REMEDY OF BUYER IS HELD TO HAVE FAILED OF ITS ESSENTIAL PURPOSE, AND WHETHER OR NOT SMSC HAS BEEN ADVISED OF THE POSSIBILITY OF SUCH DAMAGES.

## 1 Overview

The EMC2104/05 are SMBus compliant fan controllers with up to five (4 external and 1 internal) temperature channels including hardware set thermal / critical shutdown circuitry. The fan drivers can be operated using two methods each with two modes. The methods include an RPM based Fan Speed Control Algorithm and a direct fan drive setting. The modes include manually programming the desired settings or using the internal programmable temperature look-up table to select the desired setting based on measured temperature.

The temperature monitors offer 1°C accuracy (for external diodes) with sophisticated features to reduce errors introduced by series resistance and beta variation of substrate thermal diode transistors commonly found in processors.

The EMC2104/05 also include a hardware programmable temperature limit and dedicated system shutdown output for thermal protection of critical circuitry.

A block diagram of this EVB is shown in [Figure 1.1](#) below.

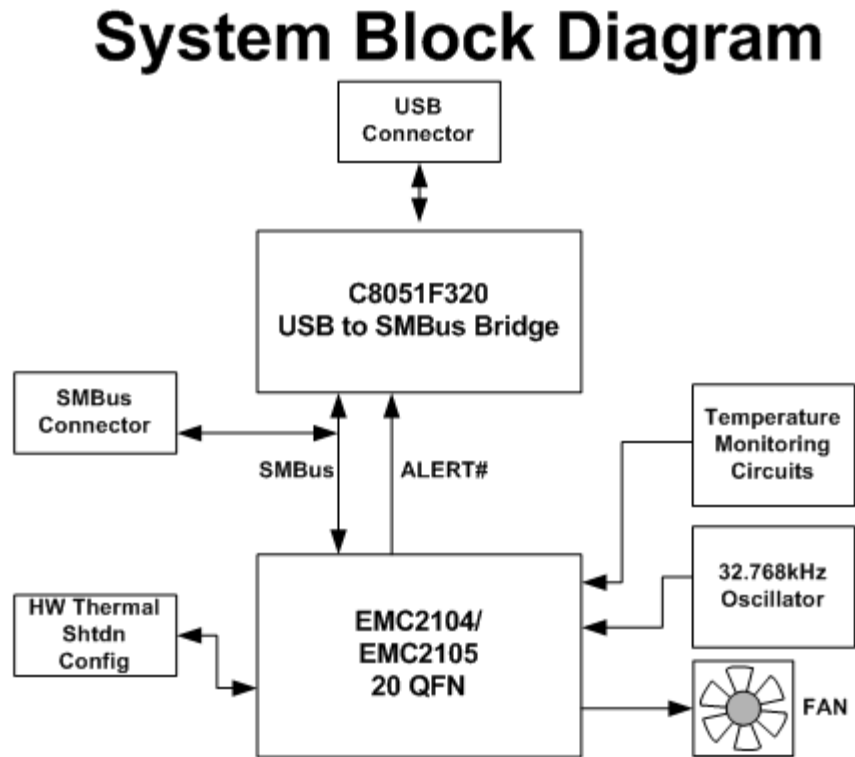

Figure 1.1 EMC2104/05 EVB Block Diagram

### 1.1 Related Documents

The CD included with the evaluation board contains the following documents:

- n Evaluation Board Checklist
- n Bill Of Materials
- n Schematic
- n Datasheet
- n Chip Manager Application
- n Register Definition File (EMC2104/05.xml and EMC2105.xml)

## 2 Getting Started

### 2.1 System Requirements

To use the EVB you will need:

- n A PC running Windows 2000 or XP
- n Display resolution 800x600 (or larger to view several windows simultaneously)
- n An available USB port

### 2.2 Feature Summary

- n The SMSC Chip Manager application allows viewing and changing register values
- n Graphing of any register
- n Headers for connecting a remote diode or CPU/GPU
- n Resistance Error Correction verification
- n Saving of settings of all registers allowing for quick loading at a later time
- n Autonomous register loading via included EEPROM
- n USB communication to evaluation board
- n An external SMBus master may also be used via jumper settings

### 2.3 Installing the EVB

1. Install the Chip Manager (ChipMan) application and device driver on a PC by running Setup.exe from the ChipMan distribution CD. A revision history and install/uninstall notes may be found in the readme.txt file on the disk.
2. Connect the supplied USB cable to an available USB port on the PC. Plug the “mini-B” end of the USB cable into EVB connector P2. The +3.3V and Bridge ACT LEDs should illuminate. After the EVB is connected to the PC the “Find New Hardware” wizard will pop up for USB driver installation. Follow the instructions in the readme.txt file to complete the installation process.
3. Start the EVB Software by selecting the Chip Manager application from the SMSC folder from the Programs Windows Start menu. The EVB will initialize and the Chip Manager Quick Help screen will appear as in [Figure 2.1](#). The USBAct LED should be blinking when the Chip Manager is running. For more help with ChipMan, select Help -> Contents for an html based help document as shown in [Figure 2.2](#).

**Note:** The SMSC ChipMan application allows viewing and changing register values for a variety of EVBs including the EMC2101, EMC2102, EMC2103, EMC2106, EMC2104 and EMC2105. The ChipMan software only needs to be installed once to support all of these EVBs. The list of supported EVBs may be found in the pulldown menu under Options -> Select Device.

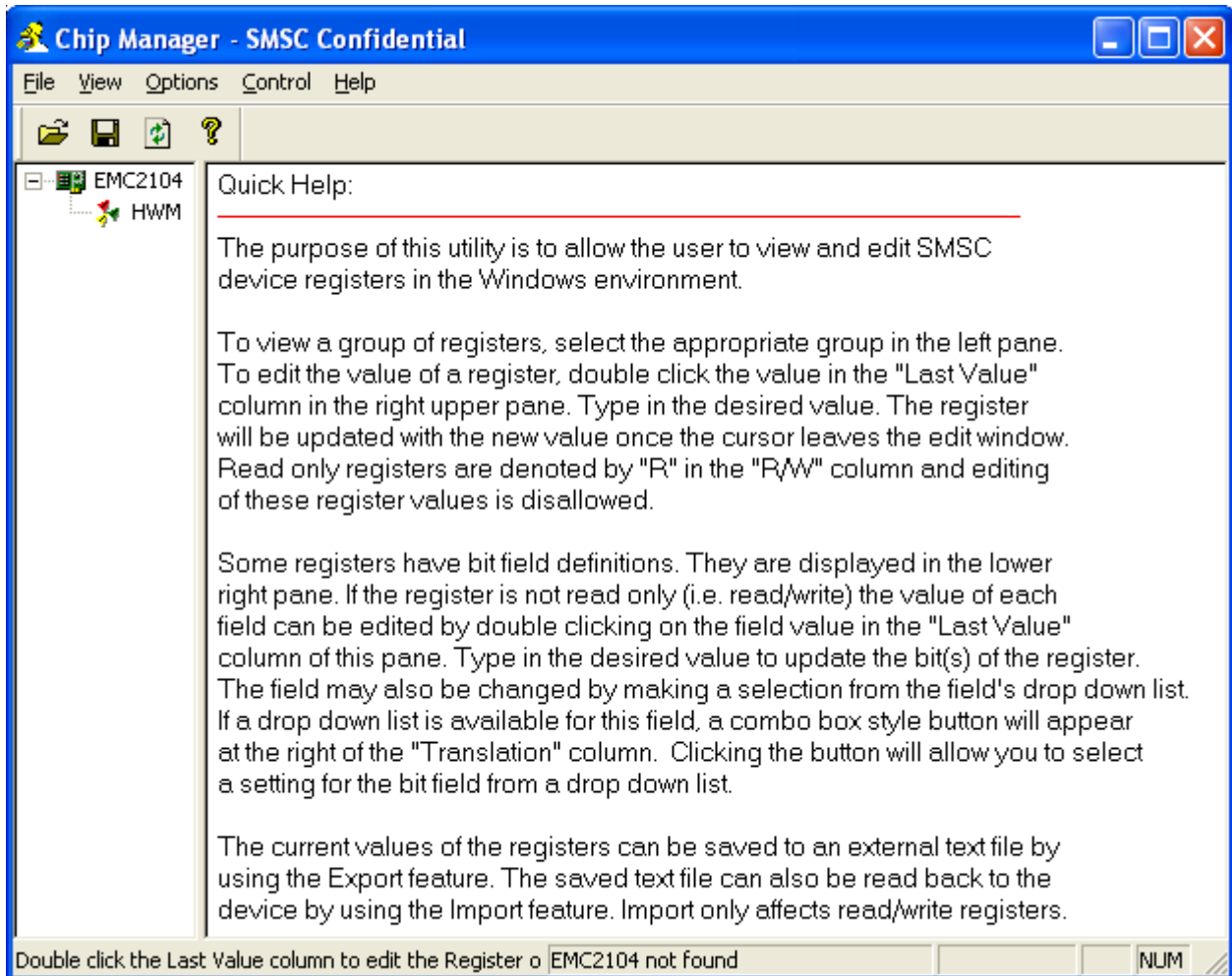

**Figure 2.1 Chip Manager Quick Help Startup Screen for the EMC2104/05**

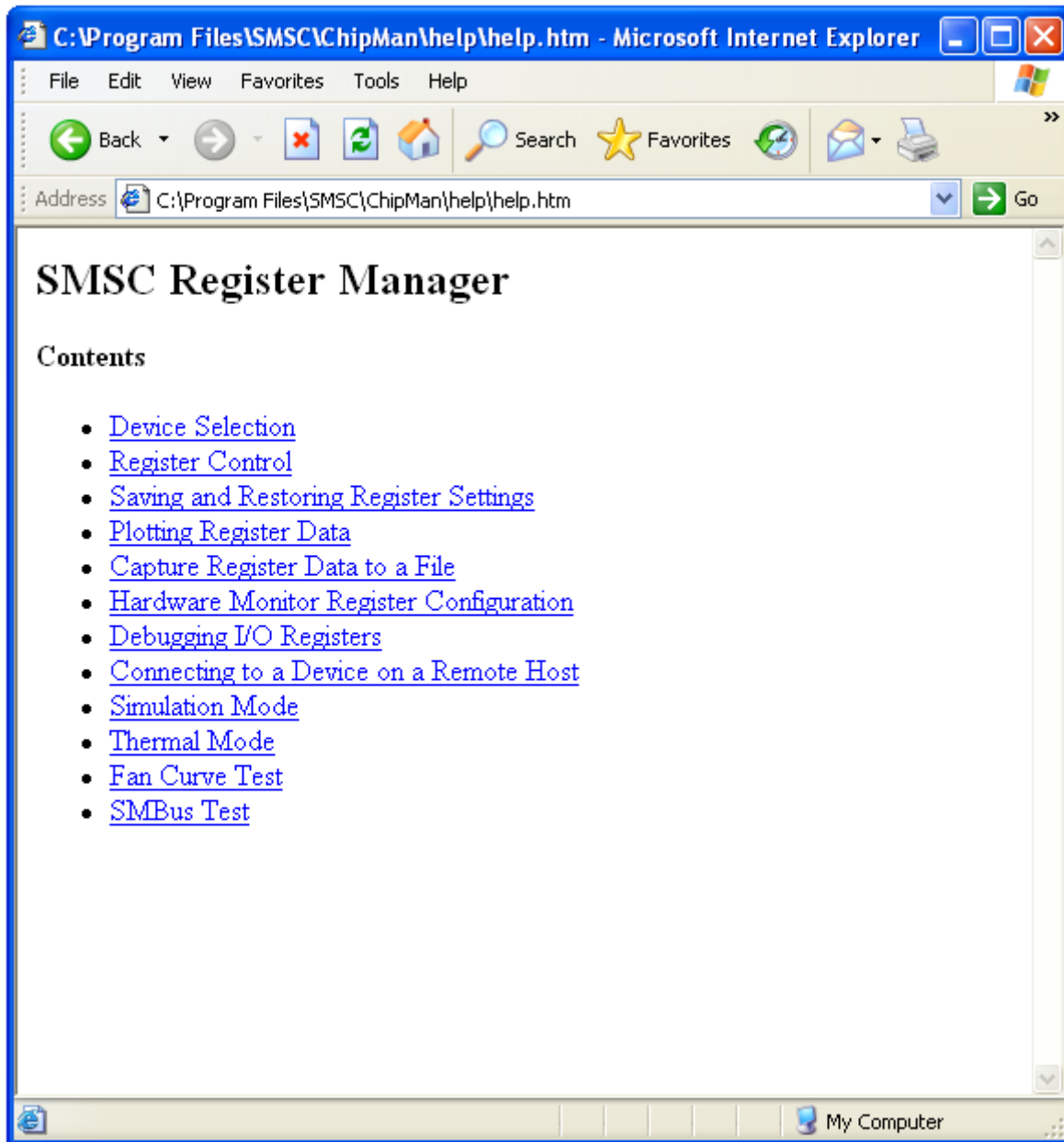

Figure 2.2 Chip Manager Help Screen

## 2.4 Board Layout

The EVB was designed for ease of use and user experimentation with easily accessible jumpers and access to the SMBus data lines. [Figure 2.3](#) below shows the silkscreen for the EMC2104/05 EVB.

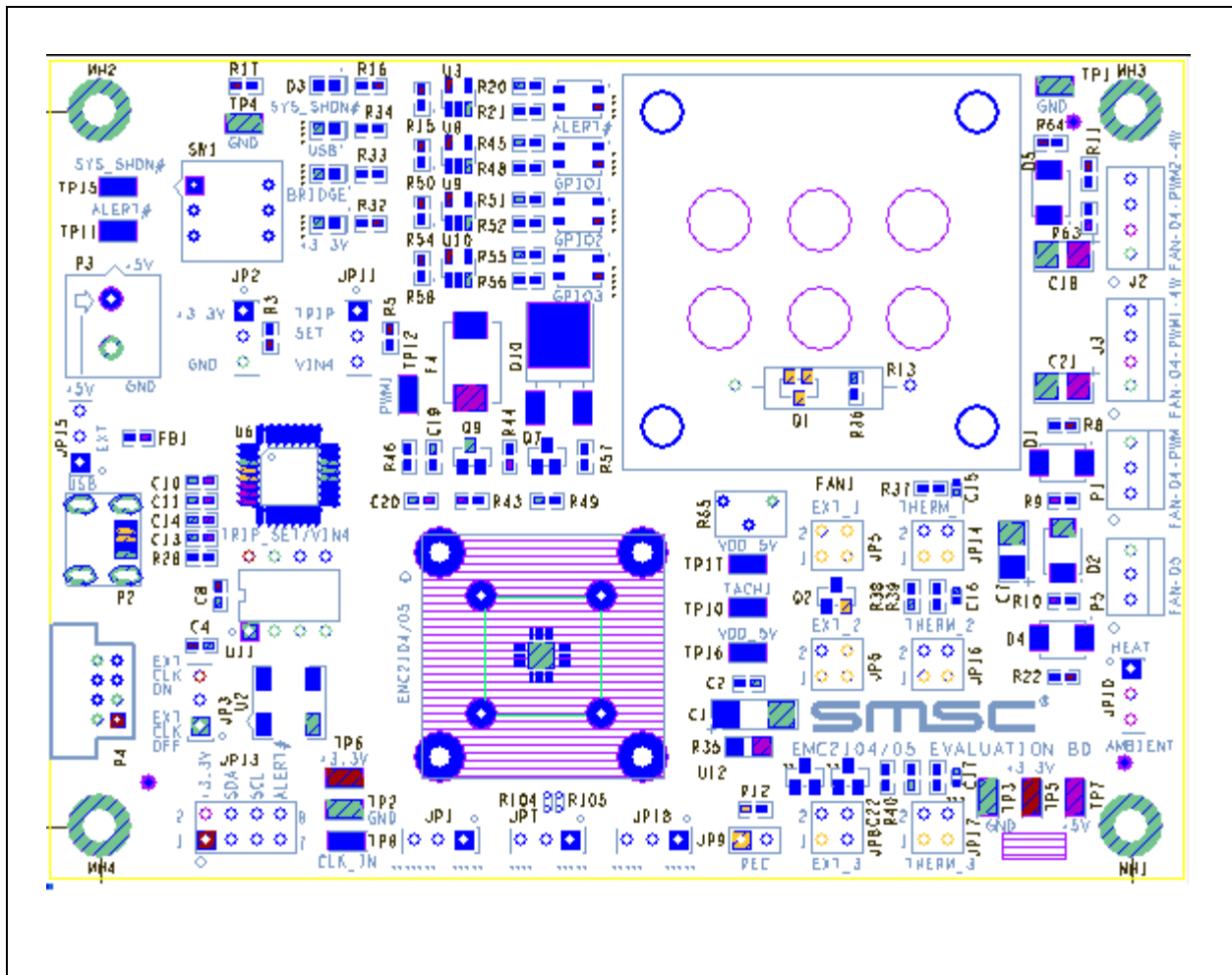

Figure 2.3 EMC2104/05 Board Outline and Silkscreen

## 3 Hardware Description

### 3.1 Introduction

The EMC2104/05 EVB provides the means to demonstrate EMC2104/05 features and to view and modify registers. LEDs indicate status information and test points are included to monitor system voltages with a user provided voltmeter or oscilloscope.

### 3.2 EMC2104/05

The EMC2104/05 is an SMBus temperature sensor with 1 internal and 4 external sensor in an 28 pin QFN package. Communications with the EMC2104/05 sensor is via the SMBus.

### 3.3 USB to SMBus Bridge

The USB to SMBus bridge is based on an 8051 microcontroller with integrated USB and SMBus interfaces as well as internal flash and RAM. During EVB manufacture, firmware is loaded into the bridge that provides the interface between the USB and the SMBus. Power is sourced to the microcontroller from the USB interface for device power and communication.

#### 3.3.1 Direct SMBus Connect Option

It is also possible to connect an external SMBus master to the EMC2104/05 EVB. A few jumper settings are all that is required to drive the EMC2104/05 :

- Simply remove the jumpers on JP13 and connect the SMBus master to the SDA, SCL, and  $\overline{\text{ALERT}}$  pins (pins 3, 5, and 7 respectively), as well as an external supply for +3.3V (pin 1).
- The +3.3V can be supplied by the SMBus bridge by leaving the +3.3V jumper in place and retaining the USB connection.

### 3.4 Connecting to Remote Diodes

This EVB is populated with jumpers (JP5, JP6, and JP8) to connect to an external diode or CPU/GPU. If connecting to a CPU's thermal diode, it is necessary to provide a common ground. Also, it is usually necessary to bias the appropriate CPU Vcc plane above this common ground to avoid forward-biasing the ESD diodes with the temperature sensor signals. Test point TP1, TP2, TP3, or TP4 can provide a ground connection. Consult the CPU manufacturer's datasheet for guidance on interfacing and biasing the thermal diode. Refer to the schematic SCH-7106.pdf for details on the EVB header connections.

### 3.5 Resistance Error Correction (REC)

External diode 3 DN signal path has a 100 ohm series resistor to demonstrate the EMC2104/05 's REC feature. The resistor may be effectively removed from the circuit by installing a jumper on JP9. See [Table 3.3](#) for details on the REC jumper settings.

### 3.6 Power Source

This EVB simply requires a single USB cable to operate. The USB-SMBus bridge regulates the +5V USB power to +3.3V used by the EMC2104/05 and other EVB circuitry. If a user-provided high current fan (>0.5A) is connected to the EVB, the user may connect a +5V power supply to terminal P3 and move jumper JP15 to position 2-3.

### 3.7 Test Points

Test points are provided for the following signals and voltages:

- Power: +3.3, +5V, and Ground

- n Outputs: FAN\_OUT, DAC2, ALERT#, OVERT1#/PWM1, OVERT2#/GPIO4, OVERT3#/GPIO5, and SYS\_SHDN#
- n Inputs: CLK\_IN and TACH1

### 3.8 LED Indicators

LEDs indicate the status of the following signals ([Table 3.1](#)).

**Table 3.1 LED Status Indicators**

LED	SIGNAL	OFF	GREEN	RED
D3	SYS_SHDN#	+3.3V power OFF	NA	SYS_SHDN# asserted
LED1	ALERT#	+3.3V power OFF	ALERT# not asserted	ALERT# asserted
LED2	OVERT1#	+3.3V power OFF	OVERT1# not asserted	OVERT1# asserted
LED3	OVERT2#	+3.3V power OFF	OVERT2# not asserted	OVERT2# asserted
	GPIO4	+3.3V power OFF	GPIO4 logic high	GPIO4 logic low
LED4	+3.3V	+3.3V power OFF	+3.3V power ON	NA
LED5	Bridge Activity	NO Activity on USB/SMBus Bridge	Activity on USB/SMBus Bridge	NA
LED6	USB Activity	NO Activity on USB port	Activity on USB port	NA
LED7	OVERT3#	+3.3V power OFF	OVERT3# not asserted	OVERT3# asserted
	GPIO5	+3.3V power OFF	GPIO5 logic high	GPIO5 logic low
LED8	GPIO1	+3.3V power OFF	GPIO1 logic high	GPIO1 logic low
LED9	GPIO2	+3.3V power OFF	GPIO2 logic high	GPIO2 logic low
LED10	GPIO3	+3.3V power OFF	GPIO3 logic high	GPIO3 logic low
LED11	GPIO6	+3.3V power OFF	GPIO6 logic high	GPIO6 logic low

### 3.9 Jumper Settings

This EVB has many jumper configurations to evaluate all of the features of the EMC2104/05 .

Fan control can conveniently be evaluated with the onboard 5V fan. Connecting this fan to J3 will allow full control from the EMC2104/05 via Chipman.

If a 5V 4-wire fan is available, connectors J1 and J2 can be used to evaluate the EMC2104/05 's ability to drive and control these types of fans. If PWM1 is to control the 4-wire fan, the appropriate register in Chipman should be set. If PWM2 is desired to drive a 4-wire 5V fan, J2 should be used. In addition, JP18 must be in position 2-3 and JP7 in Position 2-3.



Table 3.2 summarizes the options available to drive various 5V fans..

**Table 3.2 Fan Driver Configuration**

FAN DRIVER CONFIGURATION	FAN TYPE	FAN CONNECTOR	REQUIRED JUMPERS
FAN_OUT	3-wire	J3	None -
PWM1	4-wire	J1	None, SW programmed
PWM2	4-wire	J2	JP7 -Position 2-3 JP18 - Position 2-3
DAC2	2 or 3-wire	TP17	user provided offboard circuitry needed

The remote diode on board the EMC2104/05 EVB has a heater and an optional inline series resistance adjustment. Checking the REC feature of the EMC2104/05 is accomplished by removing the jumper on JP9. This adds 100 ohms of series resistance to the DN line of the diode connection. To return to 0 ohm series resistance, replace the jumper on JP9.

To heat the diode, place a jumper on JP10 in position 1-2. To return to ambient conditions, place shorting bar in position 2-3 on JP2. These remote diode options are summarized in Table 3.3 below.

**Table 3.3 Remote Diode and Thermistor Connections and Heater Settings**

NAME	JUMPER	CONDITION 1	CONDITION 2
Ext Diode 1	JP5	onboard diode JP5 - positions 1-2 and 3-4 JP14 - open	external offboard diode JP5 - connect DP to pin 1 and DN to pin 3 JP14 - open
Ext Diode 2	JP6	onboard diode JP6 - positions 1-2 and 3-4 JP16 - open	external offboard diode JP6 - connect DP to pin 1 and DN to pin 3 JP16 - open
Ext Diode 3/4	JP8	onboard diodes JP8 - positions 1-2 and 3-4 JP17 - open	external offboard diodes JP8 - connect DP to pin 1 and DN to pin 3 JP17 - open
REC	JP9	100 ohms in DN line (diode remote -) JP9 - Open	0 ohms in DN line (diode remote -) JP9- Short
HEATER	JP10	1W resistive heater on remote diode Q1 JP10 - Position 1-2	Ambient temp on remote diode Q1 JP10 - Position 2-3
Thermistor 1	JP14	onboard thermistor 1 JP14 - positions 1-2 and 3-4 JP5 - open	
Thermistor 2	JP16	onboard thermistor 2 JP16 - positions 1-2 and 3-4 JP6 - open	
Thermistor 3	JP17	onboard thermistor 3 JP17 - positions 1-2 and 3-4 JP8 - open	

This EVB also allows for GPIO control and monitoring (see [Table 3.4](#)). Switches SW1 and SW2 allow GPIO drive capabilities and LEDs provide visual confirmation of state change. .

**Table 3.4 GPIO Configurations**

CHANNEL	SW1	SW2	LED
GPIO1	switch 1	NA	8
GPIO2	switch 2	NA	9
GPIO3	switch 3	NA	10
GPIO4	NA	switch 1	3
GPIO5	NA	switch 2	7
GPIO6	NA	switch 3	11

The EMC2104/05 EVB also allows testing of all the muxed pins as well as voltage input adjustments for the TRIP\_SET and VIN4 functions. [Table 3.5](#) summarizes all of the jumpers that appear on page 2 of the schematic SCH-7106.

**Table 3.5 Jumper Selection**

JUMPER	NAME	POSITION 1-2	POSITION 2-3	OPEN
JP1	CLK_IN	GPIO1	CLK-IN TO CHIP, SW configuration required	NA
JP2	SHDN_SEL	SHDN disabled	INTEL mode 92C to 154C	AMD mode 60 to 122 C
JP3	EXT_CLK power	OFF	ON	NA
JP4	ADDR_SEL	SMBus Client, Address = 1001_101x	SMBus Client, Address = 1001_100x	EEPROM Load, Address = 1001_100x
JP11	TRIP_SET/VIN4	TRIP_SET function adjust R65 resistor pot for trip temp	VIN4 function adjust R65 resistor pot for voltage input adjustment	TRIP_SET function adjust R65 resistor pot for trip temp
JP7	GPIO3/PWM2	GPIO3	PWM2	NA
JP18	GPIO2/TACH2	GPIO2	TACH2	NA

## 4 Software Description

### 4.1 Chip Manager Overview

The Chip Manager application (ChipMan) initially displays the main Help screen, where detailed description of the application's features may be found. The Help screens can be displayed at any time by selecting Help from the menubar. ChipMan enables the user to display temperature readings, set temperature limits and read/write configuration register values.

### 4.2 Temperature/Register History Graph

To open a Temperature or Register History Graph window, select the register or registers to plot in the ChipMan application. then select Options -> Plot Register Data from the menubar. Once the graph appears, select Control -> Start to begin plotting data. The history plot continuously updates the register data reported by the EMC2104/05 . [Figure 4.1](#) below is a typical Temperature History with the external diode starting at room temp and then being heated using the HEATER jumper (JP10).

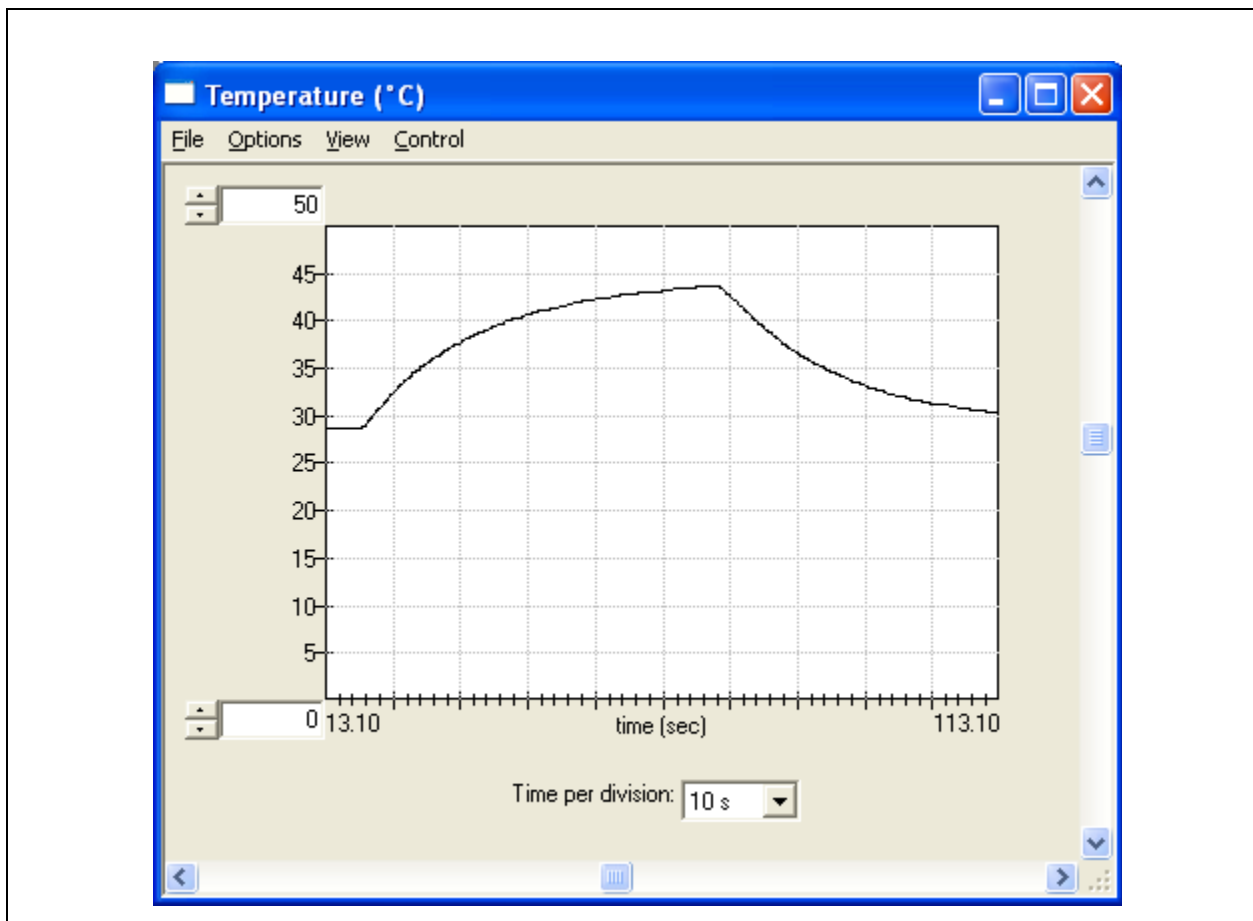

Figure 4.1 EMC2104/05 Temperature History Graph

