

RUTTONSHA

Ruttonsha International Rectifier Ltd.

SILICON RECTIFIERS

25/40 Ampere Silicon Power Diodes

FEATURES

- ⊘ All diffused series.
- ⊘ Available in normal & reverse polarity.
- ⊘ Device conforms to IS 3700 (III) & IS 4400 (III).
- ⊘ Device outline conforms to IS 5000 (Do. 5).
- ⊘ Available in avalanche characteristic.

ELECTRICAL SPECIFICATIONS		25A	40A
$I_{F(AV)}$	Maximum average forward current $T_c = 140^\circ\text{C}$	25 A	40A
V_{FM}	Maximum peak forward voltage drop @ Rated $I_{F(AV)}$	1.35 V	1.35V
I_{FSM}	Maximum peak one cycle (non-rep.) surge current 10 msec.	400 A	500A
I_{FRM}	Maximum repetitive peak forward current	150 A	200A
I^2t	Max. I^2t rating (non-rep.) 10 msec.	800 A ² Sec	1250A ² Sec

THERMAL MECHANICAL SPECIFICATIONS

θ_{J-C}	Maximum thermal resistance junction to case	1.5° C/W	1.0° C/W
θ_{C-H}	Contact thermal resistance	0.5° C/W	0.30° C/W
T_J	Operating junction temp.	-65°C to 150°C	-65°C to 150°C
T_{stg}	Storage temperature	-65°C to 160°C	-65°C to 160°C
	Mounting torque (Non-lubricated threads)	0.4 M-Kg min. 0.6 M-Kg max.	0.4 M-Kg min. 0.6 M-Kg max.
W	Approx. weight	30 gms.	30gms.

ELECTRICAL RATINGS

TYPE	NUMBER	25/40 HM/HMR	10	20	40	60	80	100	120	140	160
V_{RRM}	Max. repetitive peak reverse voltage (V)		100	200	400	600	800	1000	1200	1400	1600
V_{RSM}	Max. non-repetitive peak reverse voltage (V)		150	300	500	700	900	1100	1300	1500	1700
$V_{R(RMS)}$	Max. R.M.S. reverse voltage (V)		70	140	280	420	560	700	840	980	1120
V_R	Max. D.C. Blocking voltage (V)		100	200	400	600	800	1000	1200	1400	1600
	Recommended R.M.S. working voltage (V)		40	80	160	240	320	400	480	560	640
I_{RM}	Max. Peak reverse leakage current @ $V_{RRM}, T_J = 160^\circ\text{C}$ (mA)		15	15	15	9	9	9	9	5	5

SILICON RECTIFIERS

ORDER INFORMATION TABLE

25/40 H	M/F	R	40	G	M6
①	②	③	④	⑤	⑥

- ① - 25/40 H - without external lead
26/41 H - with external lead
- ② - M - stud with Metric threading
F - Stud with 1/4"UNF threading
- ③ - None - Normal polarity
R - Reverse polarity
- ④ - Voltage Rating (See table)
- ⑤ - None - Normal seal
G - Rotating seal
- ⑥ - None - M8 Metric Threading
M6 - M6 Metric threading

OUTLINE DIAGRAM

26/41HM

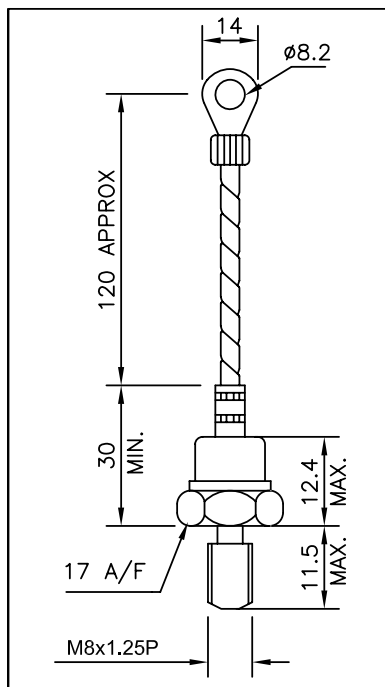

25/40HM

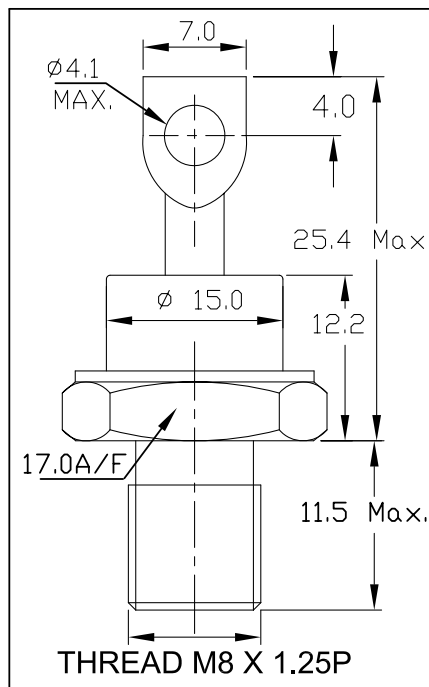

25/40HM..G

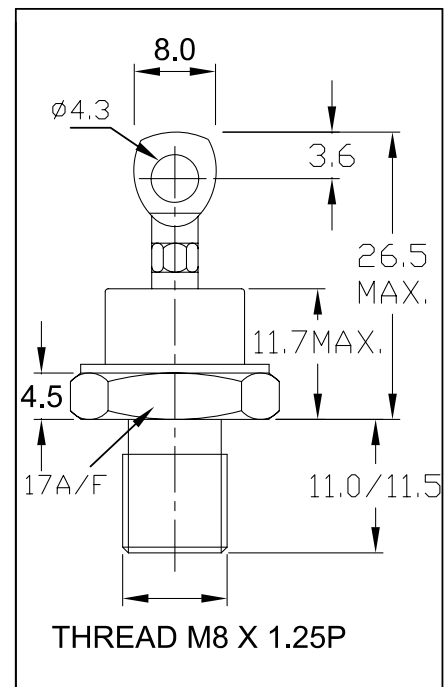

25 HM / HMR SERIES

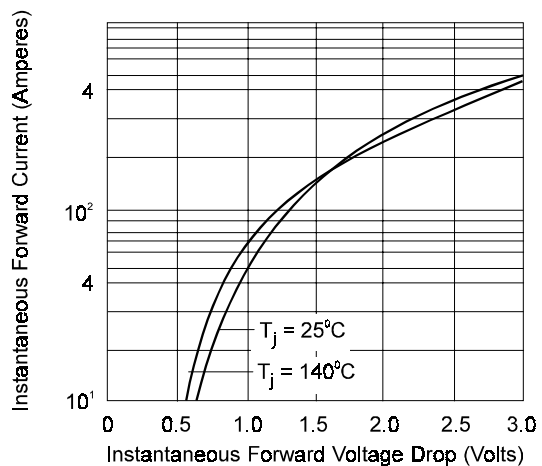

Fig. 1 - Forward Voltage Drop Vs. Forward Current

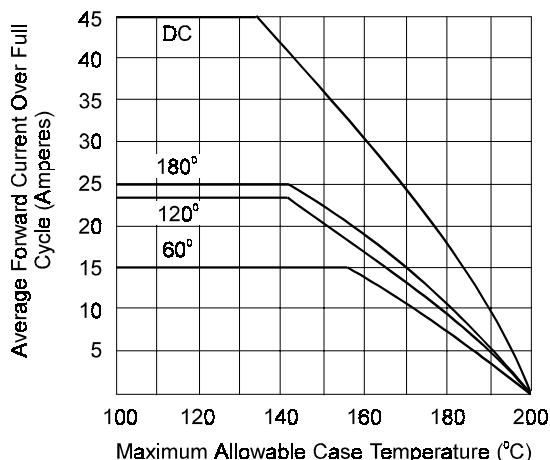

Fig. 2 - Average Forward Current Vs. Case Temperature

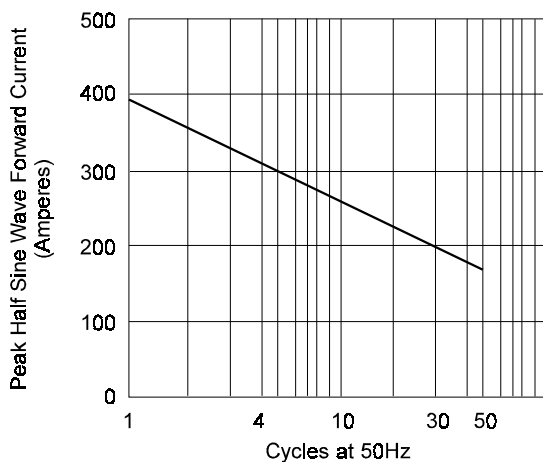

Fig. 3 - Maximum Non Recurrent Surge Current

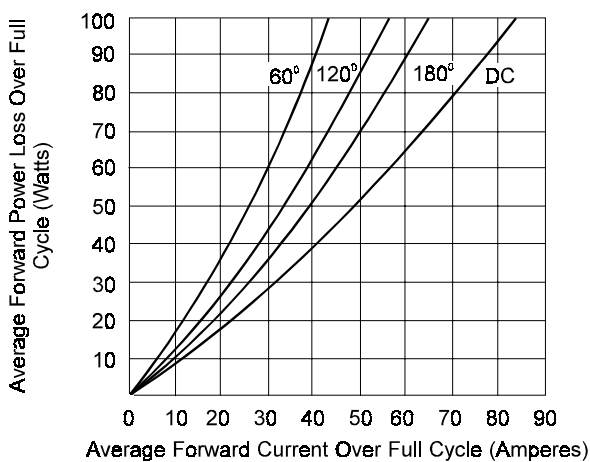

Fig. 4 - Maximum Forward Power Loss Vs. Low Level Forward Current

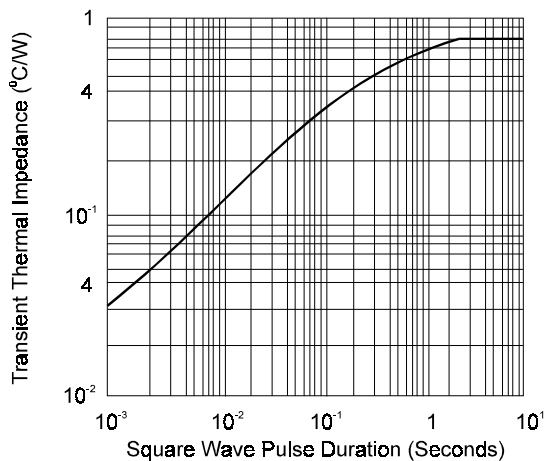

Fig. 5 - Transient Thermal Impedance

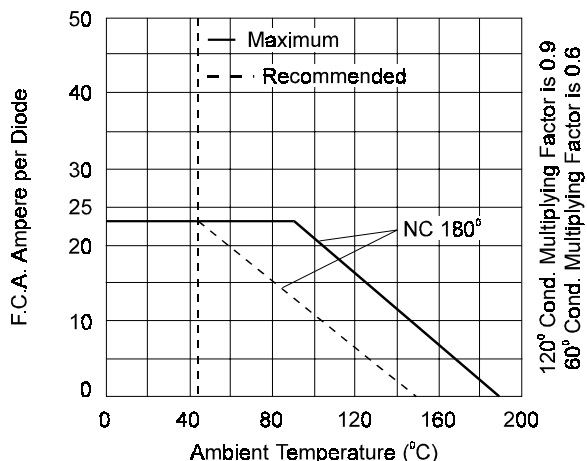

Fig. 6 - Diode Mounted on Heat Sink Type K3 with θ_{HA} -2.8° C/W

SILICON RECTIFIERS

40 HM / HMR SERIES

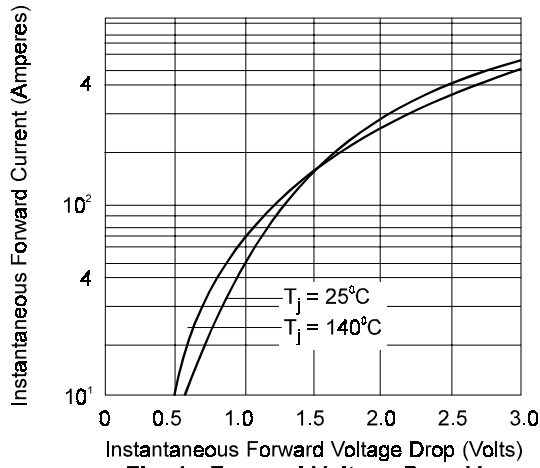

Fig. 1 - Forward Voltage Drop Vs. Forward Current

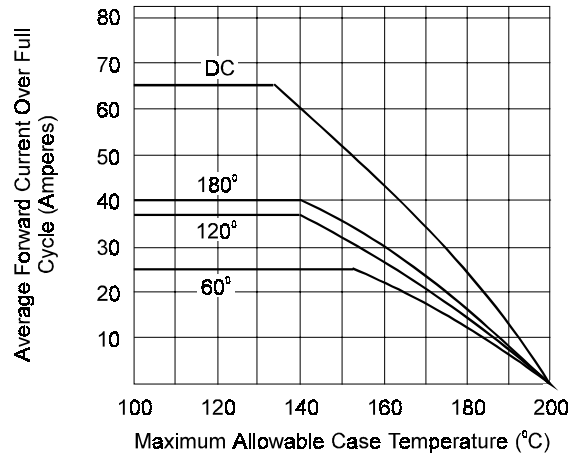

Fig. 2 - Average Forward Current Vs. Case Temperature

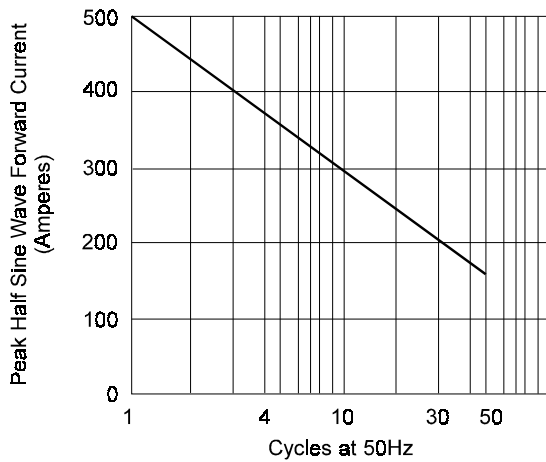

Fig. 3 - Maximum Non Recurrent Surge Current

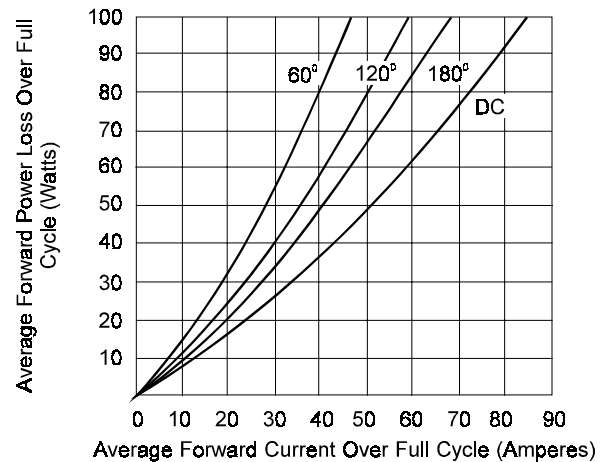

Fig. 4 - Maximum Forward Power Loss Vs. Low Level Forward Current

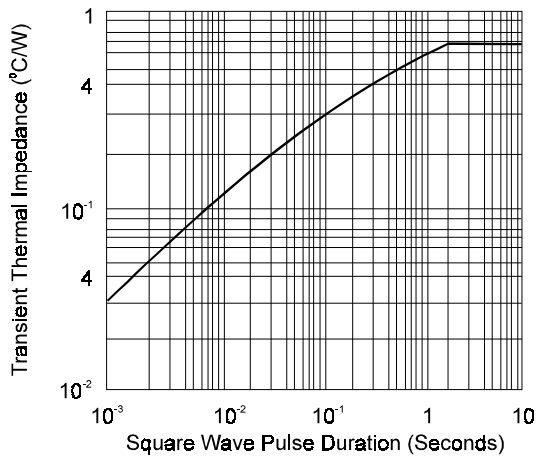

Fig. 5 - Transient Thermal Impedance

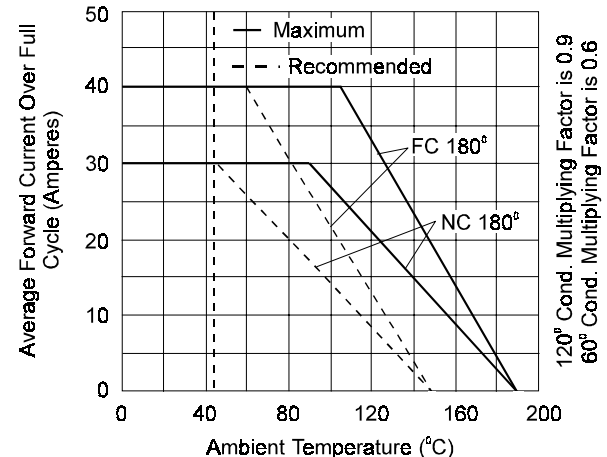

Fig. 6 - Diode Mounted on Heat Sink Type K3 with $\theta_{HA} - \text{NC } 2.5^\circ\text{C/W}$, FC 0.65°C/W