

1W005 - 1W10

Single Phase 1.0 AMP. Silicon Bridge Rectifiers

RB-15

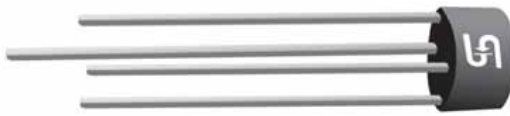

Features

- ✧ UL Recognized File # E-96005
- ✧ Surge overload ratings to 30 amperes peak
- ✧ Ideal for printed circuit board
- ✧ Reliable low cost construction technique results in inexpensive product
- ✧ High temperature soldering guaranteed:
260 °C / 10 seconds / 0.375" (9.5mm)
lead length at 5 lbs., (2.3 kg) tension

Mechanical Data

- ✧ Case: Molded plastic
- ✧ Lead: Pure tin plated, Lead free.
- ✧ Polarity: As marked
- ✧ Weight: 1.07 grams

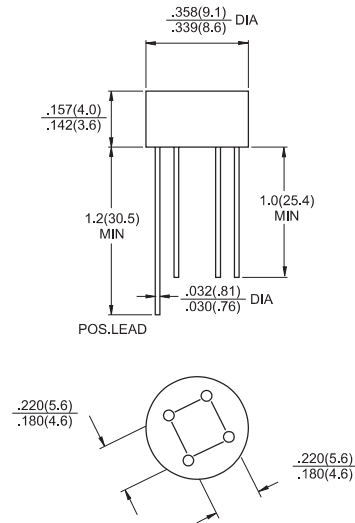

Dimensions in inches and (millimeters)

Maximum Ratings and Electrical Characteristics

Rating at 25 °C ambient temperature unless otherwise specified.
Single phase, half wave, 60 Hz, resistive or inductive load.
For capacitive load, derate current by 20%

Type Number	Symbol	1W005	1W01	1W02	1W04	1W06	1W08	1W10	Units
Maximum Recurrent Peak Reverse Voltage	V_{RRM}	50	100	200	400	600	800	1000	V
Maximum RMS Voltage	V_{RMS}	35	70	140	280	420	560	700	V
Maximum DC Blocking Voltage	V_{DC}	50	100	200	400	600	800	1000	V
Maximum Average Forward Rectified Current @ $T_A = 50^\circ\text{C}$	$I_{(AV)}$	1.0							A
Peak Forward Surge Current, 8.3 ms Single Half Sine-wave Superimposed on Rated Load (JEDEC method)	I_{FSM}	30							A
Maximum Instantaneous Forward Voltage @ 1.0A	V_F	1.0							V
Maximum DC Reverse Current @ $T_A = 25^\circ\text{C}$ at Rated DC Blocking Voltage @ $T_A = 125^\circ\text{C}$	I_R	10 500							μA μA
Typical Thermal resistance (Note)	$R_{\theta JA}$ $R_{\theta JL}$	36 13							$^\circ\text{C/W}$
Operating Temperature Range	T_J	-55 to +125							$^\circ\text{C}$
Storage Temperature Range	T_{STG}	-55 to +150							$^\circ\text{C}$

Note: Thermal Resistance from Junction to Ambient and from Junction to Lead Mounted on P.C.B. with 0.2" x 0.2" (5mm x 5mm) Copper Pads.

RATINGS AND CHARACTERISTIC CURVES (1W005 THRU 1W10)

FIG.1- MAXIMUM FORWARD CURRENT DERATING CURVE

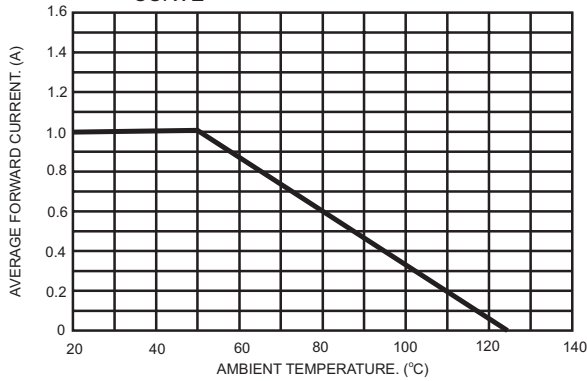

FIG.2- TYPICAL REVERSE CHARACTERISTICS PER BRIDGE ELEMENT

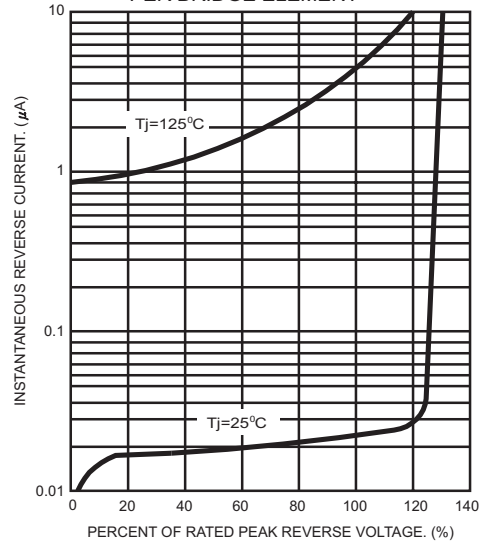

FIG.3- MAXIMUM NON-REPETITIVE FORWARD SURGE CURRENT PER BRIDGE ELEMENT

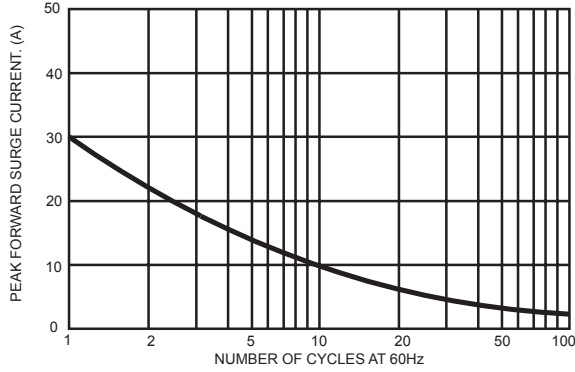

FIG.4- TYPICAL JUNCTION CAPACITANCE

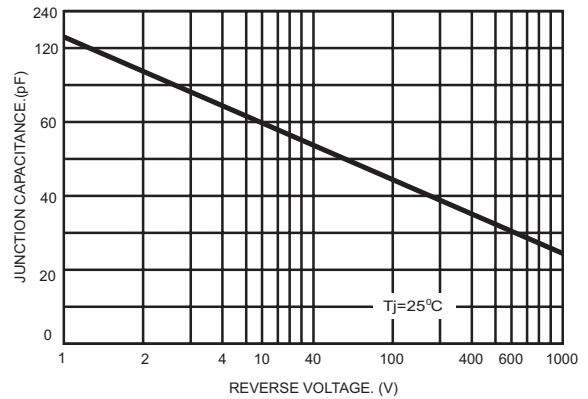

FIG.5- TYPICAL INSTANTANEOUS FORWARD CHARACTERISTICS PER BRIDGE ELEMENT

