

S1NBB80

800V 1A

特長

- 小型 DIP パッケージ
- 端子間 3.4mm

Feature

- Small-DIP
- Pin-distance 3.4mm for isolation

■外観図 OUTLINE

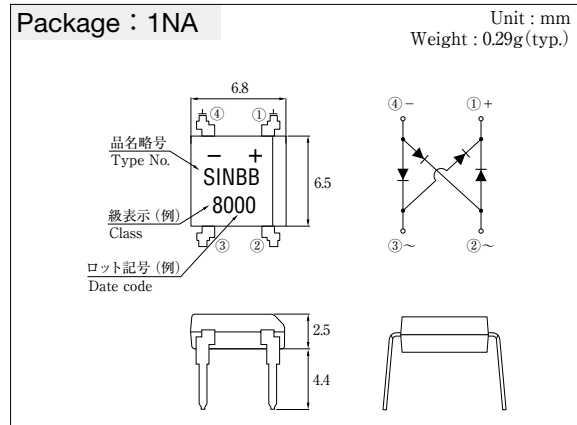
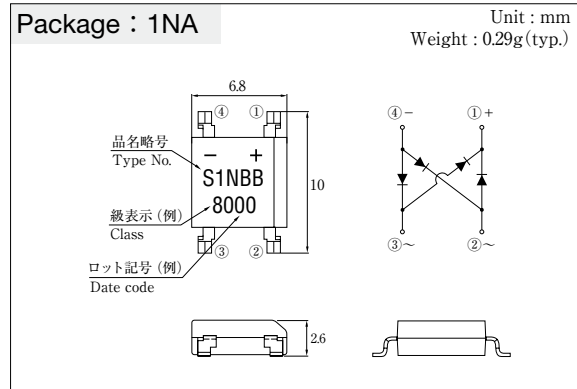

外形図については新電元 Web サイト又は〈半導体製品一覧表〉をご参照下さい。捺印表示については捺印仕様をご確認下さい。
For details of outline dimensions, refer to our web site or the Semiconductor Short Form Catalog. As for the marking, refer to the specification "Marking, Terminal Connection".

■定格表 RATINGS

●絶対最大定格 Absolute Maximum Ratings (指定のない場合 $T_l = 25^\circ\text{C}$ / unless otherwise specified)

項目 Item	記号 Symbol	条件 Conditions	品名 Type No.	S1NBB80	単位 Unit
保存温度 Storage Temperature	T_{stg}			-40~150	$^\circ\text{C}$
接合部温度 Operation Junction Temperature	T_j			150	$^\circ\text{C}$
せん頭逆電圧 Maximum Reverse Voltage	V_{RM}			800	V
出力電流 Average Rectified Forward Current	I_O	50Hz 正弦波, 抵抗負荷 50Hz sine wave, Resistance load	$T_a = 26^\circ\text{C}$ *1	1	A
			$T_a = 25^\circ\text{C}$ *2	0.84	
せん頭サージ順電流 Peak Surge Forward Current	I_{FSM}	50Hz 正弦波, 非繰り返し1サイクルせん頭値, $T_j = 25^\circ\text{C}$ 50Hz sine wave, Non-repetitive 1cycle peak value, $T_j = 25^\circ\text{C}$		50	A
電流二乗時間積 Current Squared Time	I^2t	$1\text{ms} \leq t < 10\text{ms}$, $T_j = 25^\circ\text{C}$, 1素子当たりの規格値 per diode		6	A^2s

●電氣的・熱的特性 Electrical Characteristics (指定のない場合 $T_l = 25^\circ\text{C}$ / unless otherwise specified)

順電圧 Forward Voltage	V_F	$I_F = 0.5\text{A}$, パルス測定, 1素子当たりの規格値 Pulse measurement, per diode	MAX 1.05	V
逆電流 Reverse Current	I_R	$V_R = V_{RM}$, パルス測定, 1素子当たりの規格値 Pulse measurement, per diode	MAX 10	μA
熱抵抗 Thermal Resistance	θ_{jl}	接合部・リード間 Junction to Lead	MAX 15	$^\circ\text{C}/\text{W}$
	θ_{ja}	接合部・周囲間 Junction to Ambient	*1 MAX 68 *2 MAX 84	

*1 : プリント基板実装, 銅箔パターン324mm²
On glass-epoxy substrate, copper soldering pad area 324mm²

*2 : プリント基板実装, 銅箔パターン101mm²
On glass-epoxy substrate, copper soldering pad area 101mm²

■特性図 CHARACTERISTIC DIAGRAMS

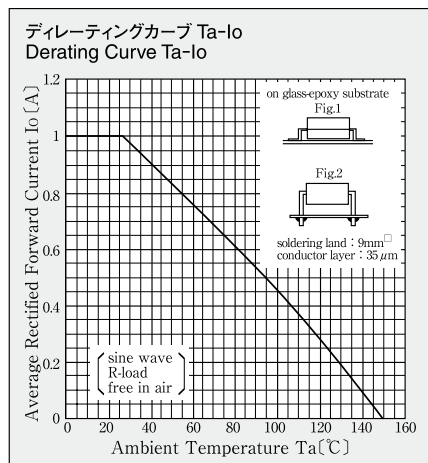
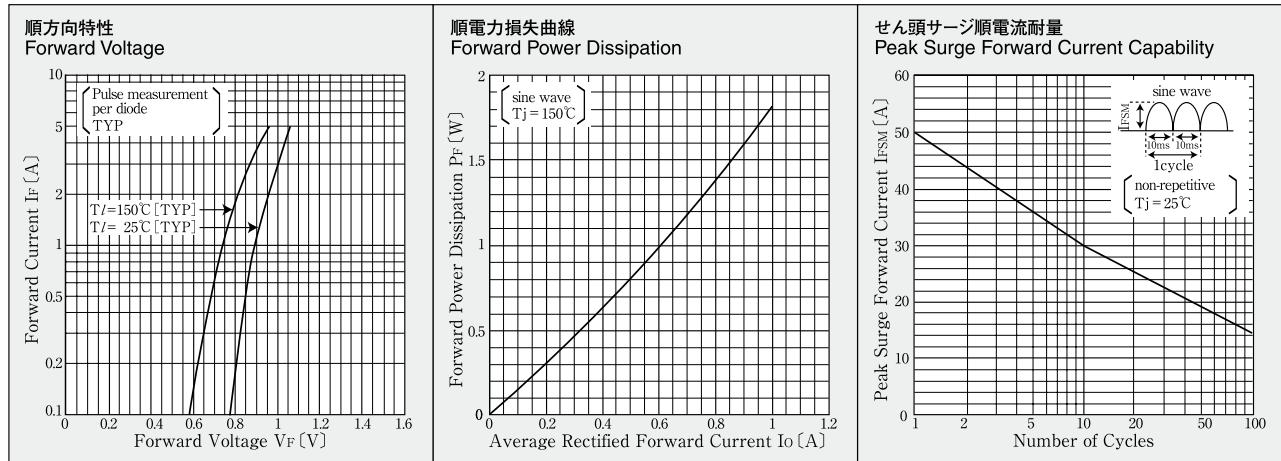

- * Sine wave は 50Hz で測定しています。
- * 50Hz sine wave is used for measurements.
- * 半導体製品の特性は一般的にバラツキを持っています。
 Typical は統計的な実力を表しています。
- * Semiconductor products generally have characteristic variation.
 Typical is a statistical average of the device's ability.