

Tous droits strictement réservés. Reproduction ou communication à des tiers sans autorisation écrite du propriétaire. Propriété de FCi. Droits de reproduction FCi.



All rights strictly reserved. Reproduction or issue to third parties in any form whatever is not permitted without written authority from the proprietor. Property of FCi. Copyright FCi.

PRODUCT NUMBER	PEG TYPE	TAIL TYPE	TAIL LGTH. DIM "A"	PCB THICKNESS	LOADING CONFIGURATION
89094-X02	PRESS	PRESS-FIT	2.90	1.6	FULLY LOADED
89094-X12	PRESS	PRESS-FIT	3.53	2.4	
89094-X02LF	PRESS	PRESS-FIT	2.90	1.6	FULLY LOADED
89094-X12LF	PRESS	PRESS-FIT	3.53	2.4	

PLATING CONTACT AREA:	
DASH NR:	PERFORMANCE LEVEL
-1YY/1YYLF	TELCORDIA CO
-2YY/2YYLF	CUSTOMER SPECIAL
-3YY/3YYLF	CUSTOMER SPECIAL

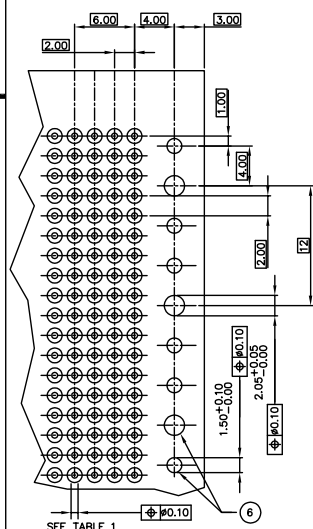
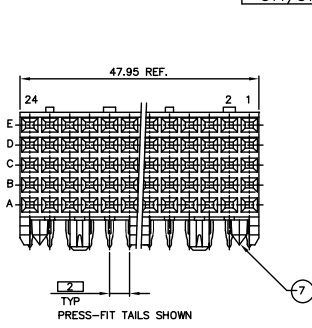
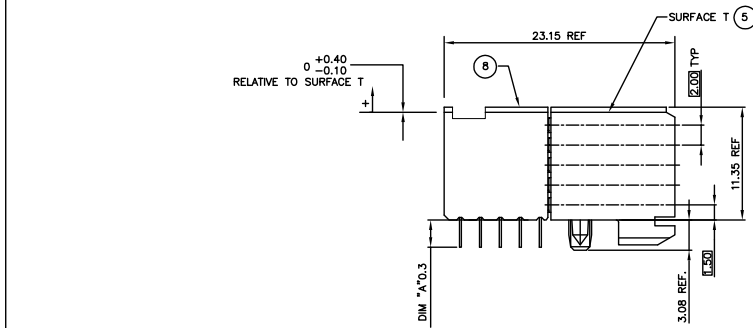

HOLE DIAMETER AFTER PLATING	0.65-0.80
DRILLED HOLE	0.81-0.86 (0.85 DRILL)
COPPER PLATING	0.025 - 0.05
SnPb PLATING	0.005-0.015

- NOTES:
- CONNECTOR MATERIALS:
HOUSING: LCP, 30% GLASS FILLED,
UL 94-V0 COMPLIANT
TERMINAL: PHOSPHOR BRONZE ALLOY
 - TAIL PLATING:
PRESS-FIT TYPE: 0.5-1.5 um TIN LEAD
 - PRODUCT SPECIFICATION:
GS-12-002
 - APPLICATION SPECIFICATIONS:
BUS-20-061
GS-20-001
TA-941
 - PRODUCT MARKING: (PART NUMBER & LOT CODE).
 - INDICATED HOLES ARE UNPLATED.
 - DIAMOND LOCATION PEG ARE ONLY EXISTED ON THE BOTH SIDES OF PRODUCT.
 - TOP SURFACE OF PRESS BLOCK MAY EXTEND UP TO 0.4MM HIGHER THAN HOUSING. THIS MAY AFFECT THE TAIL LENGTH BEFORE APPLICATION TO A BOARD.
 - THESE PRODUCTS WHERE THE PART NUMBER ENDS IN "LF" MEET THE EUROPEAN UNION DIRECTIVES AND OTHER COUNTRY REGULATIONS AS DESCRIBED IN GS-22-008.
 - ALL PRODUCTS WILL WITHSTAND EXPOSURE TO 240°C FOR 60 SECONDS IN A CONVECTION, INFAR-RED OR VAPOR PHASE REFLOW OVEN.
 - FOR LEAD FREE PART NUMBERS ADD "LF" SUFFIX. EXAMPLE: 89094-XYLF.

RECOMMENDED PC BOARD LAYOUT, COMPONENT SIDE.

mat'l. code		NOTE 1		tolerances unless otherwise specified		CUSTOMER COPY		FCi	
ltr	ecn no	dr	date	linear		projection		title	www.fciconnect.com
N	0608-0510	Cenh	12/06/06					B SERIES R/A SIGNAL RECEPT ASSY,	
P	0607-0171	Cenh	05/25/07					5 ROW, 4 MOD, PF	
R	0608-0171	TER	8/18/08	angles				product family	METRAL
S	0609-0088	Cenh	06/06/09	dr	C. DAILY	06/18/02	MM	size	dwg no
L	005-0074	LP	4/12/05	chr	M. GRAY	06/18/02	scale	A	89094
M	005-0320	TAB	6/09/05	appd	M. GRAY	06/18/02	1:1		code
sheet	revision	S							213
index	sheet	1							1 of 1

cage code 22526