

MODEL 72

3/8" Square

Single Turn

Cermet Trimming

Potentiometer

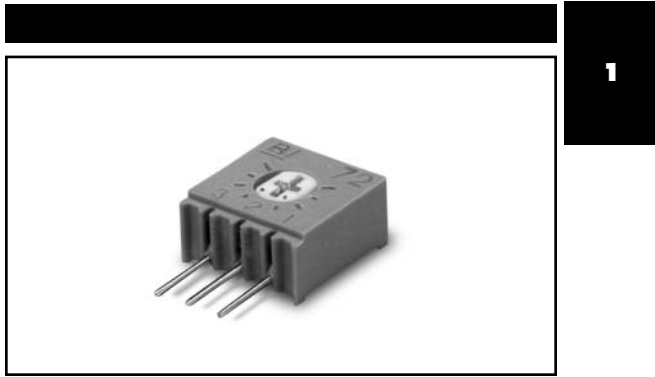

1

ELECTRICAL

| | |
|---------------------------------------|--|
| Standard Resistance Range, Ohms | 10 to 2Meg |
| Standard Resistance Tolerance | ±10% (<100 Ohms = ±20%) |
| Input Voltage, Maximum | 200 Vdc or rms not to exceed power rating |
| Slider Current, Maximum | 100mA or within rated power, whichever is less |
| Power Rating, Watts | 0.5 at 85°C derating to 0 at 125°C |
| End Resistance, Maximum | 2 Ohms |
| Actual Electrical Travel, Nominal | 244° |
| Dielectric Strength | 900 Vrms |
| Insulation Resistance, Minimum | 1,000 Megohms |
| Resolution | Essentially infinite |
| Contact Resistance Variation, Maximum | 1% or 1 Ohm, whichever is greater |

ENVIRONMENTAL

| | |
|----------------------------------|--|
| Seal | 85°C Fluorinert® (No Leaks) |
| Temperature Coefficient, Maximum | ±100ppm/°C |
| Operating Temperature Range | -55°C to +125°C |
| Thermal Shock | 5 cycles, -55°C to +125°C (1% ΔRT, 1% ΔVR) |
| Moisture Resistance | Ten 24 hour cycles (1% ΔRT, IR 100 Megohms Min.) |
| Shock, 6ms Sawtooth | 100G's (1% ΔRT, 1% ΔVR) |
| Vibration | 20G's, 10 to 2,000 Hz (1% ΔRT, 1% ΔVR) |
| High Temperature Exposure | 250 hours at 125°C (2% ΔRT, 2% ΔVR) |
| Rotational Life | 200 cycles (3% ΔRT) |
| Load Life at 0.5 Watts | 1,000 hours at 70°C (2% ΔRT) |
| Resistance to Solder Heat | 260°C for 10 sec. (1% ΔRT) |

MECHANICAL

| | |
|--------------------------|-----------------------|
| Mechanical Stops | Solid |
| Torque, Starting Maximum | 3 oz.-in. (0.021 N-m) |
| Weight, Nominal | .025 oz. (0.70 grams) |

Fluorinert® is a registered trademark of 3M Company.
Specifications subject to change without notice.



1-55

Model 72

TOP ADJUSTMENT (Inch/mm)

Model 72P

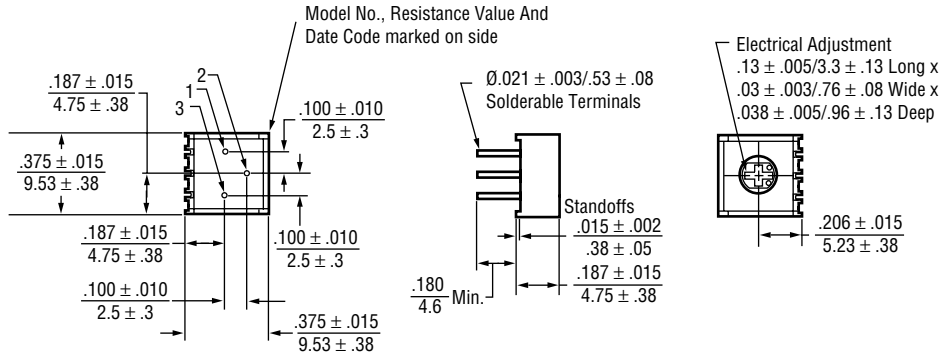

Note: Model 72P dimensions applicable to all other models except as noted.

Model 72PL

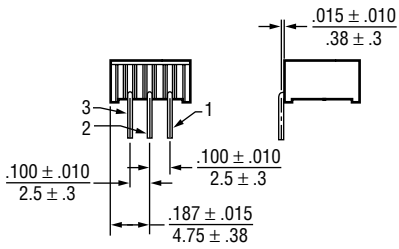

Model 72PM

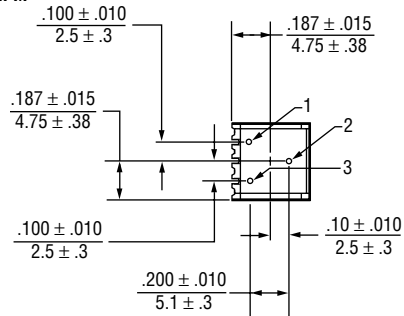

Model 72PX, 72RPX

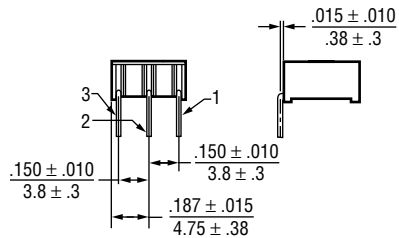

Model 72RPX - Terminals 1 and 3 are reversed

Model 72RP

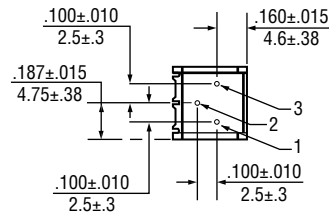

Model 72X, 72RX

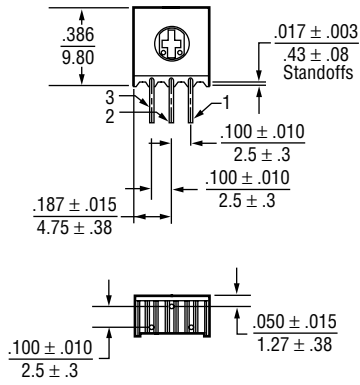

Model 72RX - Terminals 1 and 3 are reversed

Model 72XL, 72RXL, 72RW

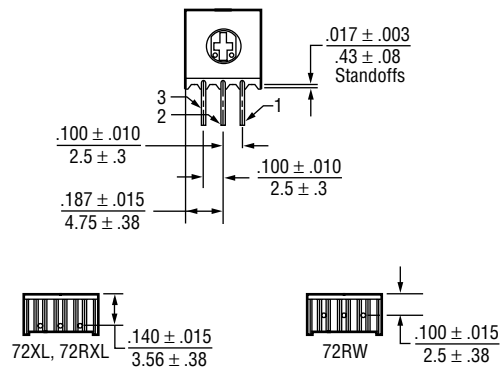

Model 72RXL And 72RW - Terminals 1 and 3 are reversed

Model 72XW, 72RXW

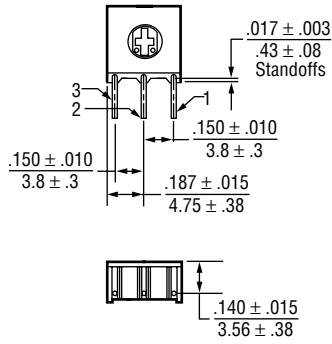

Model 72RXW - Terminals 1 and 3 are reversed

EXTENDED ROTOR OPTION (Inch/mm)

Available for all Model 72 pin styles:

72PE, 72PLE, 72PME, 72PXE, 72RPXE, 72XE, 72RXE,
72XLE, 72RXLE, 72RWE, 72XWE, 72RXWE

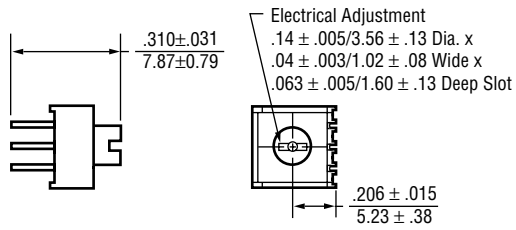

ADJUSTMENT KNOB OPTION (Inch/mm)

Available options:

72XT- Side Adjustment (See 72X for Pin Configuration)
 72PT- Top Adjustment (See 72P for Pin Configuration)

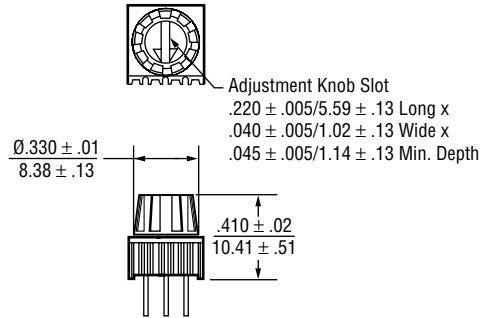

72PT Shown - Dimensions applicable to 72XT

STANDARD RESISTANCE VALUES, OHMS

| | | | | | | |
|----|-----|----|-----|------|------|------|
| 10 | 100 | 1K | 10K | 50K | 250K | 2Meg |
| 20 | 200 | 2K | 20K | 100K | 500K | |
| 50 | 500 | 5K | 25K | 200K | 1Meg | |



Standard: Boxes
Capacity = 100 Units

Option: Tubes
All units oriented with #1 pin to same side.

| | Pin Style | | P, PM | X, XL, XW, RW |
|----------|------------------|---|--------------|----------------------|
| Magazine | Width | = | 0.47" | 0.29" |
| | Height | = | 0.54" | 0.76" |
| | Length | = | 20.5" | 20.1" |
| | Capacity | = | 50 Units | 50 Units |

Option: Tape & Reel, Ammo Pack (Available only for 72RW only)
All units oriented with #1 pin to the right of the direction of feed.

| | | | |
|------|---|---|---|
| | Seat Plane to Centerline of Sprocket Hole | = | .71" (18.03 mm) |
| Tape | Width | = | 18 mm |
| | Sprocket | = | Single Hole .50" spacing |
| | Capacity | = | 1,000 Units |
| Reel | Diameter | = | 14" (356mm) |
| Ammo | Tape Fold | = | 12" (305mm) |
| | Box | = | 1.8" x 13" x 10" (46mm x 330mm x 254mm) |

ORDERING INFORMATION

Standard:

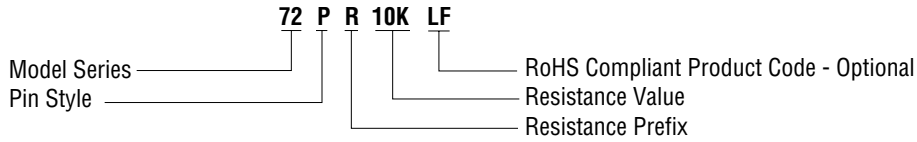

Option:

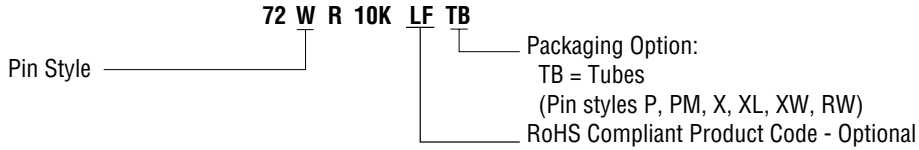

Option:

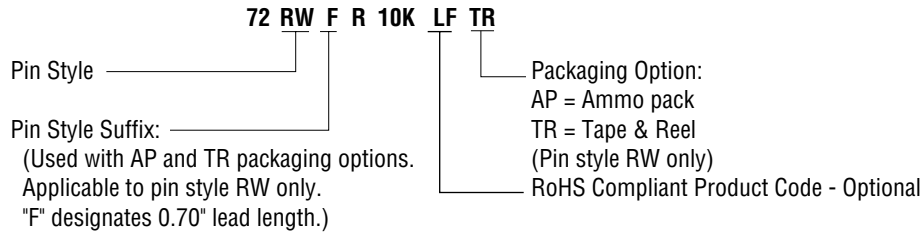

Option:

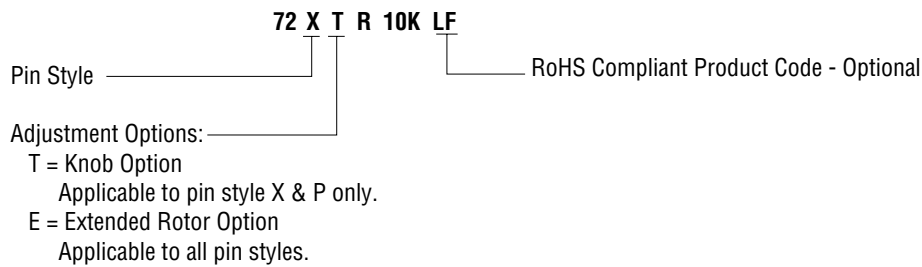

CIRCUIT DIAGRAM

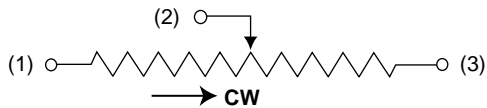

NOTES

Metric equivalents, based on 1 inch = 25.4mm are rounded to the same number of significant figures as in the original English units and are provided for general information only.

Tolerances unless otherwise specified:
Linear = ± .01 inches (.25mm)
Angular = ± 2 degrees

