

COPYRIGHT(C) 2005, OLIMEX Ltd  
<http://www.olimex.com/dev>

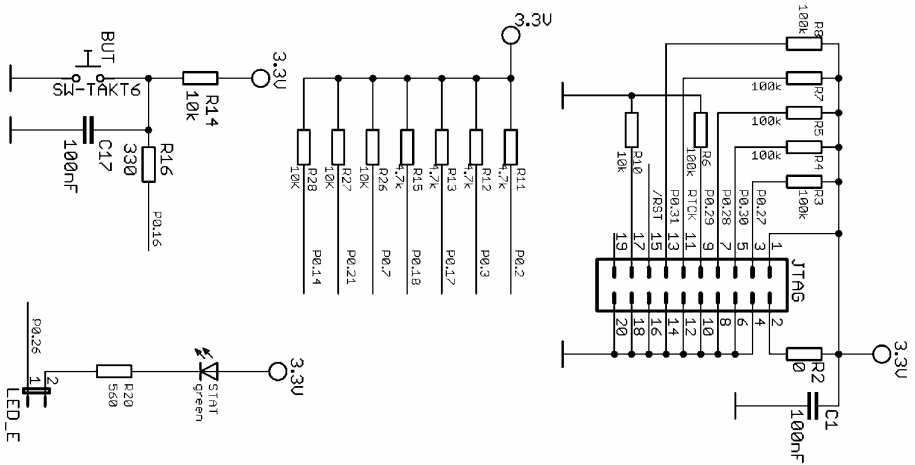

## LPC2103 BOARD HEADER ASSIGNMENTS

EXT1			EXT2		
P0.18	19	20	P0.19	GND	RST
P0.16	17	18	P0.17	Vin(5V)	3.3V
P0.14	15	16	P0.15	DBGSEL	1.8V
P0.12	13	14	P0.13	RTCK	VBAT
P0.10	11	12	P0.11	P0.30	P0.31
P0.8	9	10	P0.9	P0.28	P0.29
P0.6	7	8	P0.7	P0.26	P0.27
P0.4	5	6	P0.5	P0.24	P0.25
P0.2	3	4	P0.3	P0.22	P0.23
P0.0	1	2	P0.1	P0.20	P0.21

The port numbers are printed on the top silkscreen, the above drawings are with TOP view of the board

The distance between the headers is 1"