

PIC-P8 development board

Users Manual

Rev.A, June 2007

Copyright(c) 2007, OLIMEX Ltd, All rights reserved

INTRODUCTION:

PIC-P8 board is low cost development board, which allow you to prototype and develop code for all Microchip's PIC microcontrollers with 8 pins.

What you can do with PIC-P8? A lot of stuff let's see what we have:

PIC-P8 have RS232 connector and driver, so you can interface your PIC microcontroller to other embedded or PC with RS232. The PIC-P8 RS232 driver is made with tricky schematic to reduce the cost and the negative RS232 level is generated using the opposite RS232 driver negative level, thus to operate the opposite driver should be real RS232 driver i.e. you can connect PIC-P8 to computer or other board with RS232 driver but if you connect two PIC-P8 together they will not talk to each other as none of them is able to produce negative voltage levels.

PIC-P8 have also external EEPROM which could be connected to PIC on the board via two SMD jumpers, as J2 and J3 share same pins as the ceramic resonator if you want to use I2C you must run on internal oscillator.

This board is so small that it have no ICSP connector i.e. to program the PIC you should pull it from the socket and use programmer with ZIF socket like PIC-MCP, PIC-MCP-USB, or PIC-PG2, PIC-PG3.

The power supply circuit have voltage regulator and could be powered with +9-25VDC. The polarity is written on the silkscreen. There is protection diode so if you connect the power supply reverse nothing wrong will happend.

The oscillator circuit is made with 4 Mhz ceramic resonator, so you can run your PIC at maximum performance.

GP0-GP5 are available next to prototype area and you can solder additional circuits easy to the microcontroller.

FEATURES:

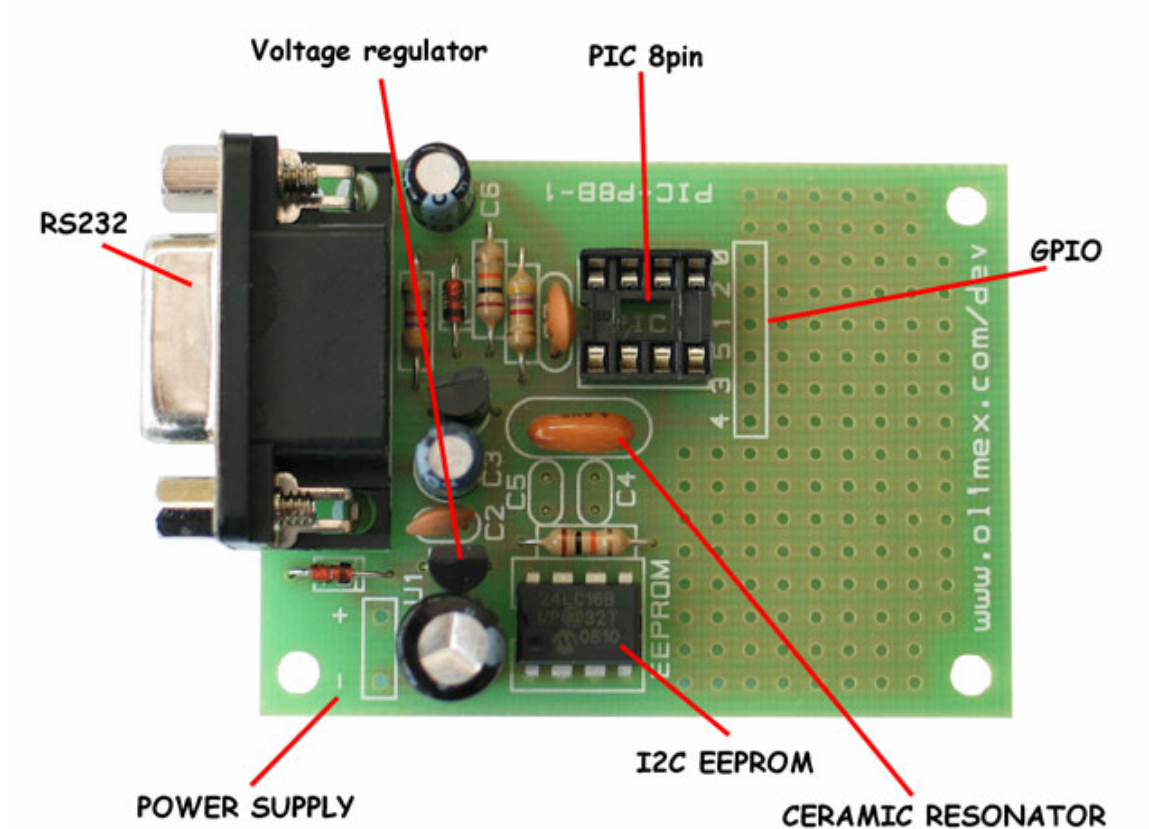

- RS232 interface with level shifter circuit
- GPIO ports available next to prototype area
- DIL8 microcontroller socket
- Ceramic resonator 4 Mhz
- EEPROM I2C memory
- Input protection diode
- Voltage regulator +5V, 100mA
- Grid 100 mils
- GND bus
- Vcc bus
- Three mounting holes 3,3 mm (0,13")
- FR-4, 1.5 mm (0,062"), green soldermask, white silkscreen component print
- Dimensions 58x43 mm (2,3 x 1,7")



All boards produced by Olimex are ROHS compliant

HARDWARE:

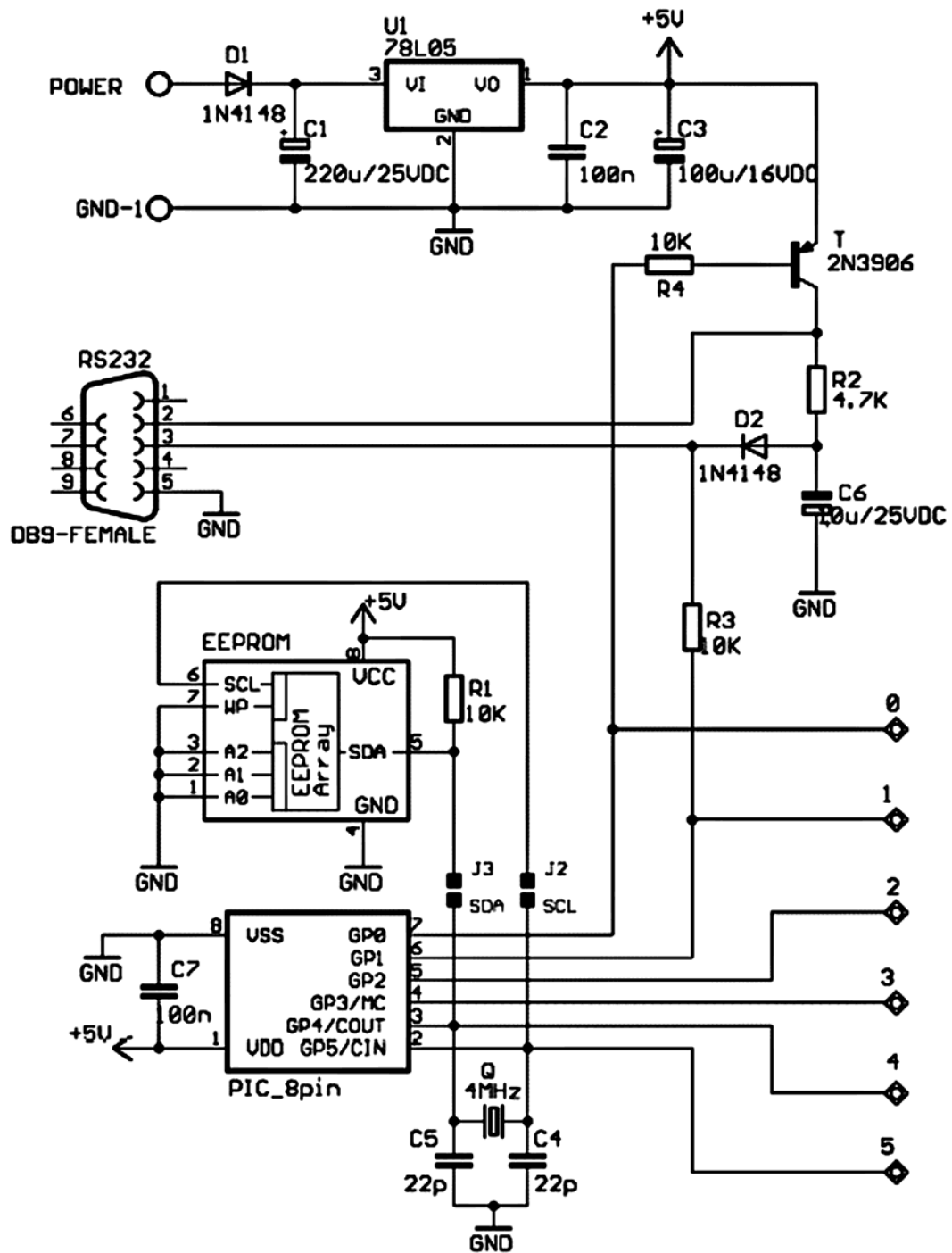

Copyright (C) 2002 OLIMEX Ltd
<http://www.olimex.com/dev>

SOFTWARE:

DEMO1: PIC12F675-I/P ADC read

This demo code show how to initialize and read the PIC12F675 ADC.

DEMO2: PIC12F675-I/P EEPROM read / write

This demo code show how to initialize and read/write EEPROM with bit banging technique without having PIC witch special I2C controller.

DEMO3: PIC12F675-I/P RS232 send / receive routines

This demo code show how to send and receive to RS232 with bit bank technique without having PIC with UART.

ORDER CODE:

PIC-P8 - assembled and tested (no kit, no soldering required)

PIC-P8/PCB - blank PCBs only

How to order?

You can order to us directly or by any of our distributors.

Check our web www.olimex.com/dev for more info.

Revision history:

REV.A - create June, 2007

Disclaimer:

© 2007 Olimex Ltd. All rights reserved. Olimex®, logo and combinations thereof, are registered trademarks of Olimex Ltd. Other terms and product names may be trademarks of others.

The information in this document is provided in connection with Olimex products. No license, express or implied or otherwise, to any intellectual property right is granted by this document or in connection with the sale of Olimex products.

Neither the whole nor any part of the information contained in or the product described in this document may be adapted or reproduced in any material from except with the prior written permission of the copyright holder.

The product described in this document is subject to continuous development and improvements. All particulars of the product and its use contained in this document are given by OLIMEX in good faith. However all warranties implied or expressed including but not limited to implied warranties of merchantability or fitness for purpose are excluded.

This document is intended only to assist the reader in the use of the product. OLIMEX Ltd. shall not be liable for any loss or damage arising from the use of any information in this document or any error or omission in such information or any incorrect use of the product.