



MAX6765 Evaluation Kit

General Description

The MAX6765 evaluation kit (EV kit) provides a proven printed-circuit board (PCB) layout that facilitates evaluation of the MAX6765 low-quiescent-current, high-voltage linear regulator. This EV kit is a fully assembled and tested surface-mount board.

With a few simple changes detailed in a later section, this EV kit can also evaluate the MAX6766–MAX6774.

The MAX6765 EV kit includes connections to the regulator, the enable signal, the watchdog timer, and the microprocessor (μ P) reset line. An LED indicates the status of the voltage regulator and jumpers provide control over all major features of the MAX6765. The MAX6765 EV kit withstands temperatures ranging from -40°C to $+105^{\circ}\text{C}$ and the MAX6765 IC withstands temperatures ranging from -40°C to $+125^{\circ}\text{C}$.

The EV kit comes with the MAX6765TTL2+ installed. To evaluate the pin-compatible MAX6766 or the MAX6767–MAX6774, contact the factory for free samples.

Features

- ◆ Wide Supply Voltage Range: 4V to 72V
- ◆ 100mA Regulator Output Current
- ◆ Can Also Evaluate MAX6766–MAX6774

Ordering Information

PART	TYPE
MAX6765EVKIT+	EV Kit

+Denotes lead-free and RoHS-compliant.

Component List

DESIGNATION	QTY	DESCRIPTION
C1, C5	0	Not installed, capacitors
C2	1	1 μ F \pm 20%, 100V X7R ceramic capacitor TDK C3225X7R2A105M AVX 1210C105KAT9A
C3	1	10 μ F \pm 20%, 10V X7R ceramic capacitor TDK C3225X7R1C106M
C4	1	0.022 μ F \pm 10%, 16V X7R ceramic capacitor (0603) TDK C1608X7R1H223K
LED1	1	Green LED (1206)

DESIGNATION	QTY	DESCRIPTION
J1, J4, J6	3	2-pin headers
J2, J3, J5	0	Not installed, headers
R1, R7	2	100k Ω \pm 1% resistors (0805)
R2, R3, R5, R6	0	Not installed, resistors (0805)
R4	1	150 Ω \pm 1% resistor (0805)
U1	1	MAX6765TTL2+ (6-pin TDFN-EP) or MAX6766 (optional)
U1a	0	Not installed (optional), MAX6767–MAX6774 (8-pin TDFN-EP)
—	3	Shunts, 2-position (see Table 1 for jumper functions)
—	1	PCB: MAX6765 Evaluation Kit+

Component Suppliers

SUPPLIER	PHONE	FAX	WEBSITE
AVX Corp.	602-678-0384	602-678-0385	www.avx.com
TDK Corp.	847-390-4373	847-390-4428	www.component.tdk.com

Note: Indicate that you are using the MAX6765–MAX6774 when contacting these component suppliers.

MAX6765 Evaluation Kit

Quick Start

Recommended Equipment

Before beginning, the following equipment is needed:

- An adjustable output power supply capable of supplying at least 12V at 100mA

Procedure

The MAX6765 EV kit is fully assembled and tested. Follow the steps below to verify board operation:

- 1) Ensure that jumpers J1, J4, and J6 are shorted.
- 2) Connect the power supply to the IN and GND connections.
- 3) Set the power supply output to 12V and observe LED1.

Detailed Description

The MAX6765 operates from 4V to 72V and provides a fixed or adjustable regulator output. The regulator can source 100mA, subject to thermal dissipation limits. Table 1 lists the function of each jumper on the EV kit.

Voltage Regulator Output

OUT provides a regulated voltage at 5V.

Reset Timeout

The reset output remains asserted for a certain minimum period, which is controlled by jumper J6. If J6 is shorted, the reset period is the default of 12.5ms. If J6 is open, capacitor C4 sets the timeout period to 26.8ms, but this can easily be changed using the following equation:

$$t_{RP} = C_4 \left(1.22 \times 10^6 \frac{V}{A} \right)$$

where t_{RP} is in seconds and C4 is in farads. Refer to the MAX6765-MAX6774 IC data sheet for more information on capacitor selection.

Table 1. Jumper Functions (J1–J6)

JUMPER	POSITION	FUNCTION
J1	Open	Regulator disabled
	Closed*	Regulator enabled
J2 (MAX6767/ MAX6768 only)	Open	Hold mode disabled
	Closed	Hold mode enabled
J3 (MAX6771/ MAX6772 only)	Open	ENABLE2 low
	Closed	ENABLE2 high
J4	Open	LED1 disabled
	Closed*	LED1 enabled
J5 (MAX6767– MAX6774 only)	1-2	Regulator voltage set by R5 and R6
	2-3	Regulator voltage fixed
J6	Open	Reset timeout set by C4 to 26.8ms
	Closed*	Reset timeout fixed at 12.5ms

*Default position.

MAX6765 Evaluation Kit

Evaluates: MAX6765-MAX6774

Evaluating the MAX6766-MAX6774

This EV kit can also be used to evaluate the MAX6766-MAX6774. The MAX6766 uses the 6-pin TDFN footprint (U1) on the EV kit and the MAX6767-MAX6774 use the 8-pin TDFN footprint (U1a). Each of these parts shares the same pin connections except for pin 4. R2, R3, J2, and J3 work differently depending on the part. See Table 2 for the modifications needed for a particular part.

RESETIN Comparator

The MAX6769/MAX6770 have a RESETIN comparator that asserts $\overline{\text{RESET}}$ if the voltage falls below the comparator threshold. The threshold voltage on IN can be set using the following formula:

$$V_{\text{IN_TH}} = V_{\text{TH}} \left(1 + \frac{R_3}{R_2} \right)$$

where V_{TH} is either 1.085V (M/S/Y/V suffixes) or 1.147V (L/T/Z/W suffixes) and R3 and R2 are $\leq 200\text{k}\Omega$. Do not exceed the 12V absolute maximum rating for RESETIN.

Adjustable Output

With the MAX6767-MAX6774, OUT provides regulated DC at a voltage set by jumper J5, which selects either the fixed output voltage or the output voltage set by resistive dividers R5 and R6. This can easily be changed according to the following equation:

$$V_{\text{OUT}} = V_{\text{SET}} \left(1 + \frac{R_6}{R_5} \right)$$

where $V_{\text{SET}} = 1.233\text{V}$ and R5 and R6 are $\leq 200\text{k}\Omega$.

Table 2. EV Kit Modifications

PARTS	DESCRIPTION	PARTS CHANGED				
		R2	R3	J2	J3	J5, R5, R6
MAX6765/MAX6766	Unmodified EV kit	Open				
MAX6767/MAX6768	Pin 4 is the $\overline{\text{HOLD}}$ input	Open		Add jumper to control $\overline{\text{HOLD}}$	Open	See Adjustable Output section
MAX6769/MAX6770	Pin 4 is the RESETIN comparator	Add resistive divider to set the comparator threshold		Open		
MAX6771/MAX6772	Pin 4 is the second enable	Add 100k Ω pulldown resistor	Open		Add jumper to second enable	
MAX6773/MAX6774	Pin 4 is the watchdog timer input	Open		Open		

MAX6765 Evaluation Kit

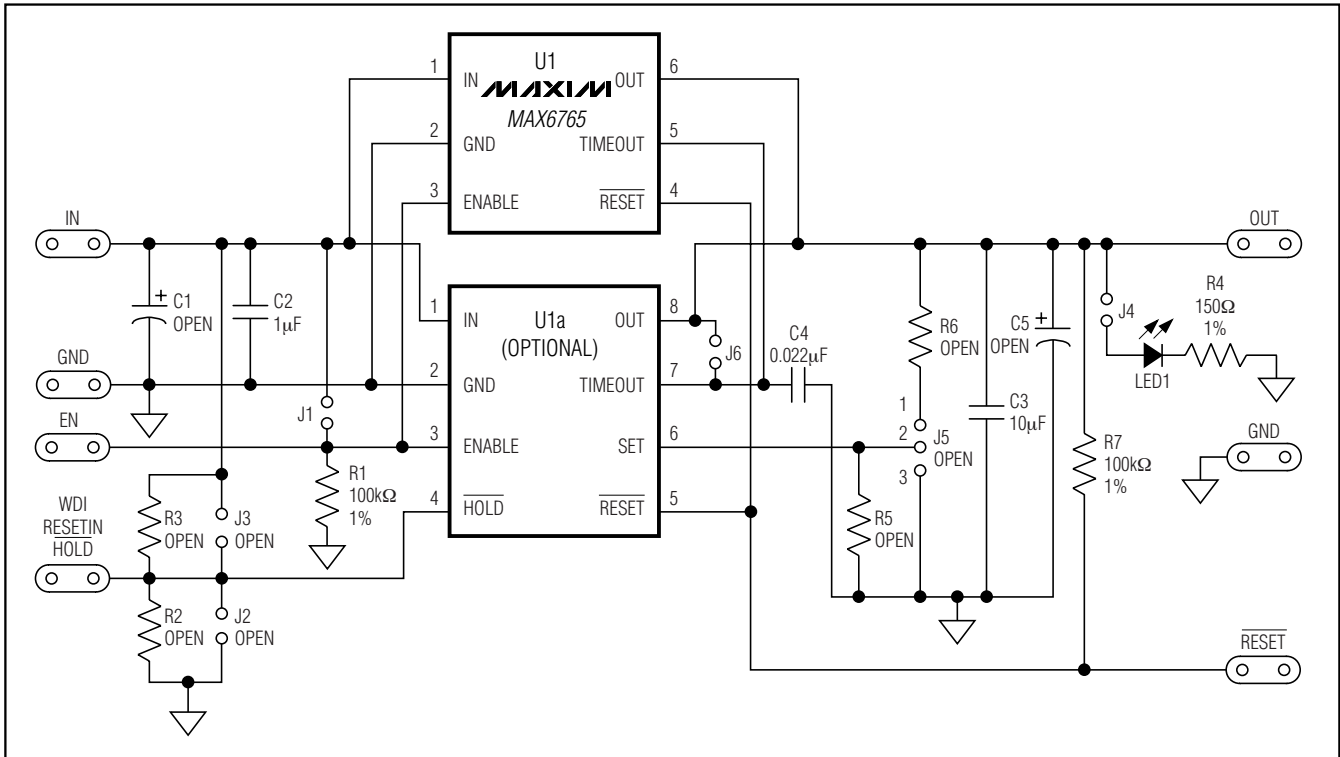

Figure 1. MAX6765EV Kit Schematic

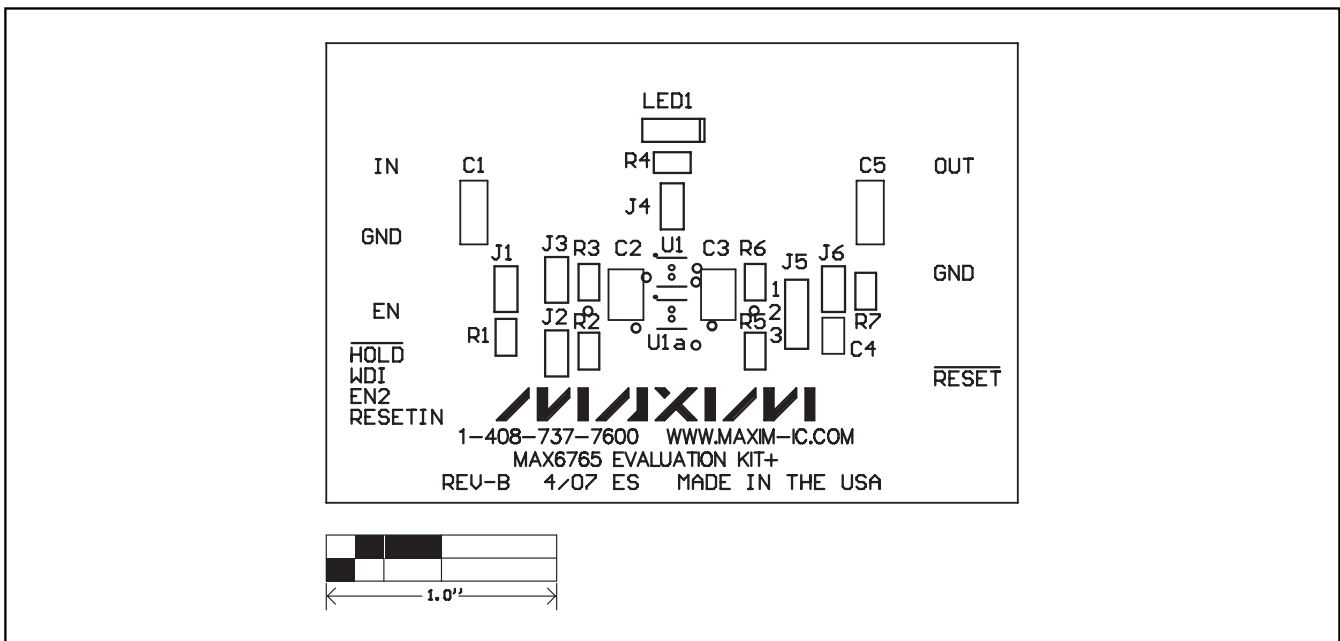

Figure 2. MAX6765 EV Kit Component Placement Guide—Components Side

MAX6765 Evaluation Kit

Evaluates: MAX6765-MAX6774

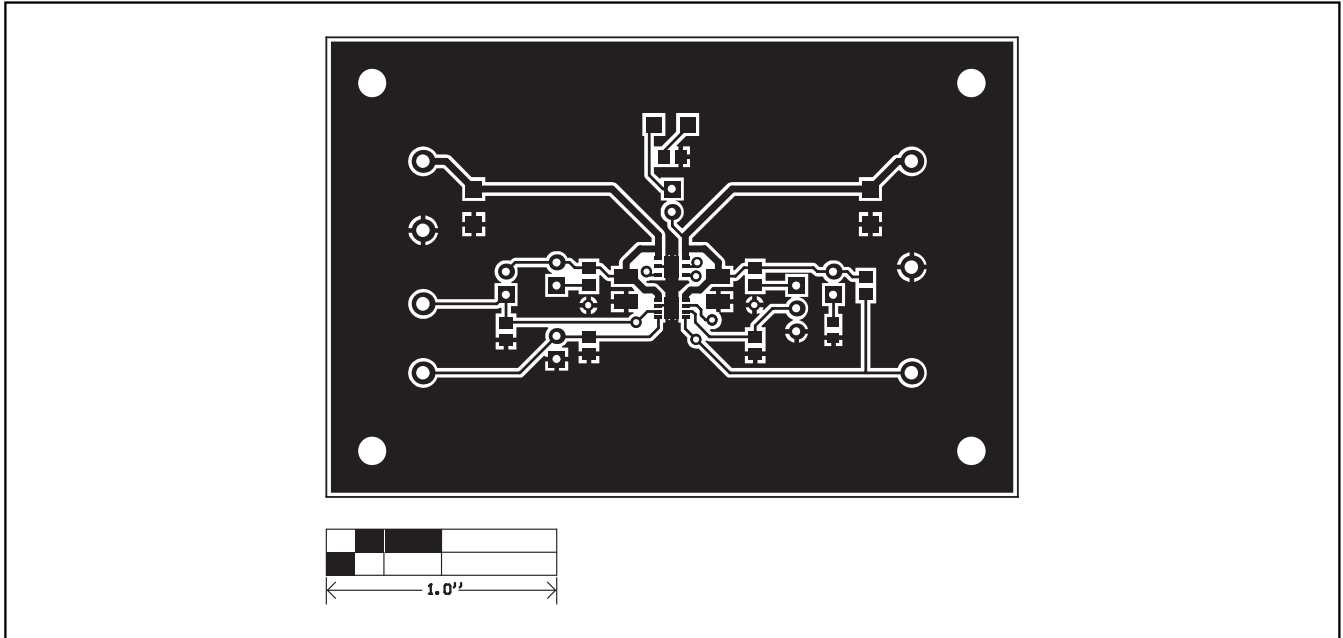

Figure 3. MAX6765 EV Kit PCB Layout—Component Side

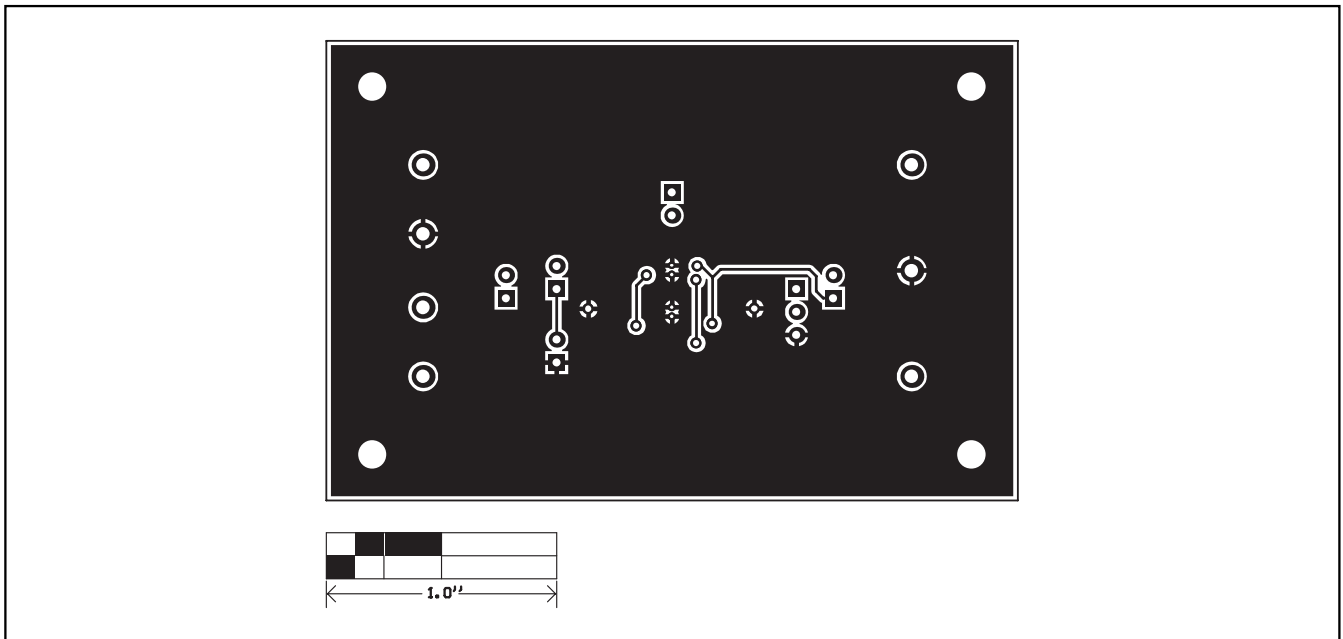

Figure 4. MAX6765 EV Kit PCB Layout—Solder Side

Maxim cannot assume responsibility for use of any circuitry other than circuitry entirely embodied in a Maxim product. No circuit patent licenses are implied. Maxim reserves the right to change the circuitry and specifications without notice at any time.

Maxim Integrated Products, 120 San Gabriel Drive, Sunnyvale, CA 94086 408-737-7600 _____ 5

© 2007 Maxim Integrated Products

MAXIM is a registered trademark of Maxim Integrated Products, Inc.