

# Enpirion EN5366QI 6A DCDC Converter w/Integrated Inductor Evaluation Board

## Introduction

Congratulations! You are evaluating a complete power system on silicon:

- The EN5366QI features integrated inductor, power MOSFETS, Gate Drive, Compensation Network, and controller and protection circuitry. This level of integration delivers a substantial reduction in footprint and part count over competing solutions.
- The EN5366QI features resistor divider output voltage programming. The resistor divider allows the user to set the output voltage to any value within the range 0.8V to  $(V_{IN}-V_{DROPOUT})$ . The evaluation board utilizes a small trim pot to adjust the output voltage. There is also a footprint for a fixed 0805 sized resistor to replace the trim pot.
- The user can also program the Over-Voltage-Protection (OVP) trip level using a separate resistor divider. The board does NOT come with the OVP resistors populated
- The input capacitor is a 10V rated 47uF X5R MLCC. The output filter section is populated with 5 x 10uF 6.3V rated X5R MLC capacitors to achieve the required ~50uF of output capacitance. The combination of 5 x 10uF caps yields a very low ESR and hence low output ripple. A single 47uF capacitor can be substituted if a minimum footprint configuration is desired. The Soft-start capacitor is a small 10V rated 15nF X5R MLCC.
- Pads are available to add up to one additional input capacitor and there are a total of 5 pads to accommodate the output capacitor(s). This allows for evaluation of performance over a wide range of input/output capacitor combinations.
- Easy jumpers are provided for the following signals:
  - Enable
- Numerous test points are provided as well as banana plugs for input and output connections
- The board comes with input decoupling and reverse polarity protection to protect the device from common setup mishaps.

## Quick Start Guide

Figure 1 shows a top view of the evaluation board.

**WARNING:** complete steps 1 through 4 before applying power to the EN5366QI evaluation board.

STEP 1: Set the “ENABLE” jumper to the Disable Position.

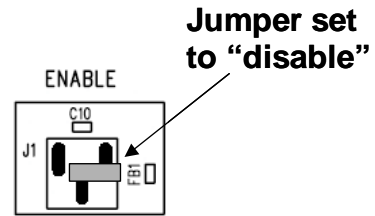

STEP 2: Connect Power Supply to the input power connectors, VIN (+) and GND (-) as indicated in Figure 1.

**CAUTION:** be mindful of the polarity. Even though the evaluation board comes with reverse polarity protection diodes, it is rarely a good idea to reverse the input polarity.

STEP 3: Connect the load to the output connectors VOUT (+) and GND (-), as indicated in Figure 1.

STEP 4: Apply  $V_{IN}$  to the board and move the ENABLE jumper to the enabled position. The EN5366QI is now powered up!

**NOTE:** There is no de-bouncing circuitry associate with the enable pin.

**NOTE:** The trim pot is set at the factory to a predetermined output voltage. To adjust to another output voltage setting, turn the screw on the trim pot while monitoring the output voltage using an accurate volt-meter.

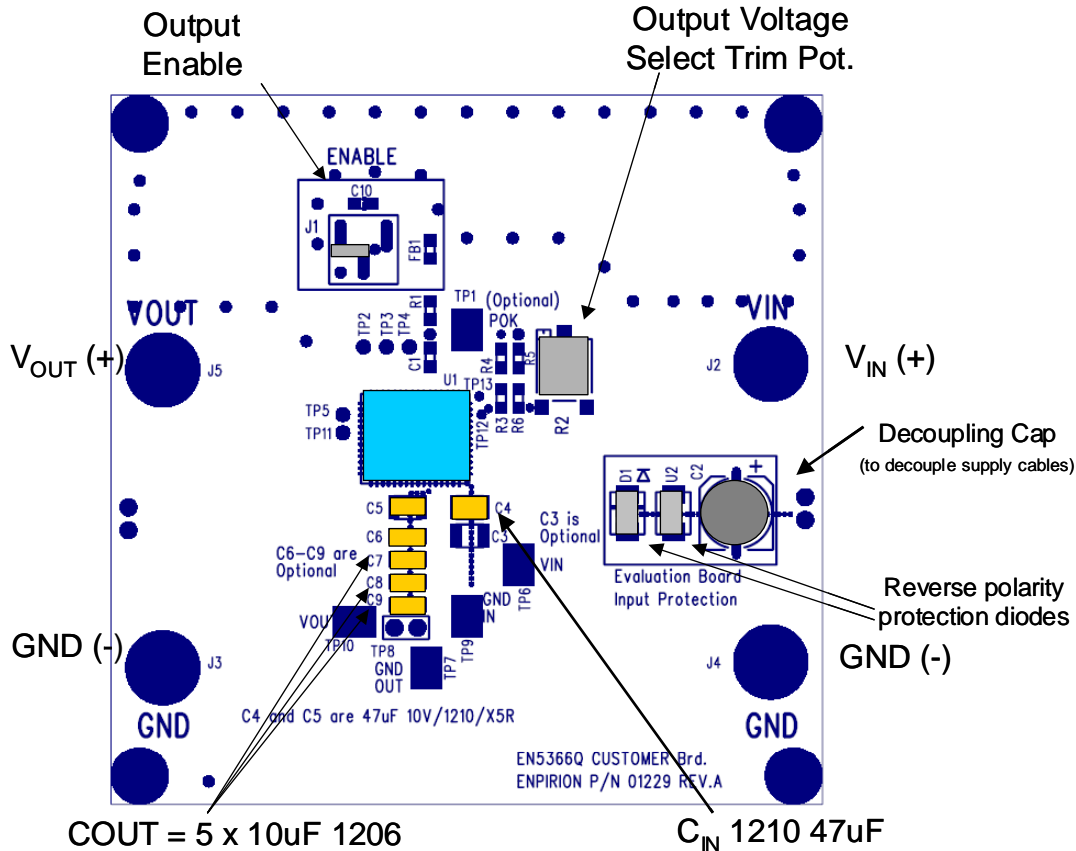

Figure 1. Evaluation Board Layout.

## Output Voltage Select

### Programming Output Voltage and OVP

The EN5366QI output voltage is programmed using a simple resistor divider network. Figure 2 shows a schematic view of the resistor divider configuration. The evaluation board uses a trim pot in place of resistor Ra1.

The EN5366QI output voltage and over voltage thresholds are determined by the voltages presented at the XFB and XOVP pins respectively. These voltages are set by way of resistor dividers between V<sub>OUT</sub> and AGND with the midpoint going to XFB and XOVP.

It is recommended that Rb1 and Rb2 resistor values be ~2kΩ. Use the following equation to set the resistor Ra1 for the desired output voltage:

$$R_{a1} = \frac{(V_{out} - 0.75V) * R_{b1}}{0.75V}$$

If over-voltage protection is desired, use the following equation to set the resistor  $R_{a2}$  for the desired OVP trip-point. Note that the evaluation board leaves these resistors un-populated.

$$R_{a2} = \frac{(OVP_{trip} - 0.90V) * R_{b2}}{0.90V}$$

By design, if both resistor dividers are the same, the OV trip-point will be 20% above the nominal output voltage.

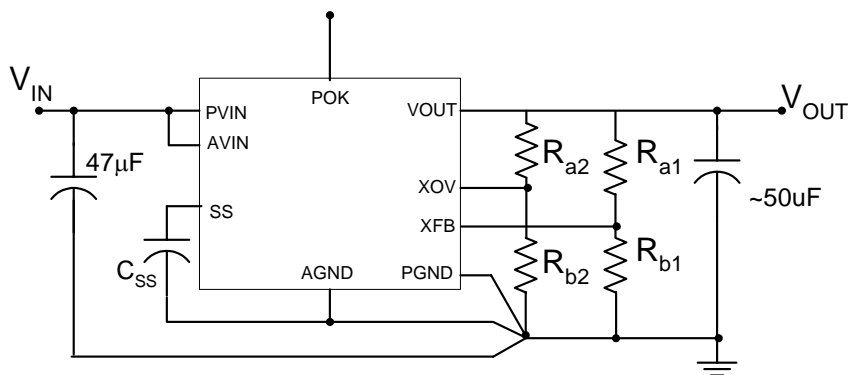

**Figure 2.**  $V_{OUT}$  and OVP resistor divider networks.

**NOTE:** if no OVP divider is present, there will be no over-voltage protection and POK will remain "high" as long as  $V_{OUT}$  remains above 90% of the nominal  $V_{OUT}$  setting.

## Test Recommendations

To guarantee measurement accuracy, the following precautions should be observed:

1. Make all input and output voltage measurements at the board using the test points provided. This will eliminate voltage drop across the line and load cables that can produce false readings.
2. Measure input and output current with series ammeters or accurate shunt resistors. This is especially important when measuring efficiency.
3. Use a balanced impedance probe tip to measure switching signals to avoid noise coupling into the probe ground lead.

## Input and Output Capacitors

The **input** capacitance requirement is 47uF for the EN5366QI. Enpirion recommends that a low ESR MLC capacitor be used. The voltage rating should be rated high enough to provide adequate margin for your application. There is a pre-tinned pad for one additional 1210 capacitor to experiment with input filter performance.

The **output** capacitance requirement is approximately 50uF of capacitance. The EN5366QI-E evaluation board comes populated with 5 x 10uF 6.3V 1206 MLC capacitors. The 5 parallel capacitors provide for reduced ESR and hence lower output ripple voltage. If a minimum footprint configuration is desired, the 5 x10uF capacitors can be replaced with a single 47uF MLC capacitor.

**NOTE:** Capacitors must be X5R or X7R dielectric formulations.

**NOTE:** Please refer to product datasheet for specific recommendations.

## Contact Information

Enpirion, Inc.  
685 Route 202/206  
Suite 305  
Bridgewater, NJ 08807  
Phone: 908-575-7550  
Fax: 908-575-0775

*Enpirion reserves the right to make changes in circuit design and/or specifications at any time without notice. Information furnished by Enpirion is believed to be accurate and reliable. Enpirion assumes no responsibility for its use or for infringement of patents or other third party rights, which may result from its use. Enpirion products are not authorized for use in nuclear control systems, as critical components in life support systems or equipment used in hazardous environment without the express written authority from Enpirion.*

