



XChip SoC – Networking and Web Services on a Chip

- ▶ Connects to host microcontroller for serial to Ethernet (LAN) applications
- ▶ Robust networking and applications firmware included – no coding required; zero royalty licensing agreement
- ▶ Integrated 10-100 MAC/PHY; 256K SRAM; up to 921 Kbps data rate
- ▶ Compact 12mm x 12mm 184 BGA package
- ▶ Firmware includes web server, Email and SNMP support



Powerful Device Networking & Embedded Web Server in a Deployment-Ready Chip

A member of the DeviceLinx™ XChip™ family of networking system-on-chip solutions, the XChip SoC is a turnkey and application-bundled co-processor for device networking. It delivers the same high-performance connectivity and web server capabilities as the market-leading XPort® embedded device server module.

Manufacturers of high-volume, price-sensitive products can now rapidly and affordably offer networking, complete with built-in web server for remote monitoring and control, as a standard feature on virtually any product with a serial interface on its microcontroller.

Highly-integrated Networking Co-Processor

Fabricated using an industry-standard CMOS process, the XChip is a highly-integrated x86-class processor that includes a built in Ethernet MAC and 10-100 PHY, 256 KB zero wait-state SRAM, up to 3 GPIOs and a high-performance serial UART in a compact 12mm x 12mm 184 BGA RoHS-compliant, industrial temperature package.

Simply connect the serial port to the XChip and load the royalty-free standard application and network protocol firmware in an external Flash chip. Finish by adding an RJ45 jack and magnetics to instantly connect virtually any product to an Ethernet network or the Internet and serve web pages!

A dedicated networking co-processor, it enables the host microcontroller to function at maximum capacity without the computing burdens of network and web server processing. Serial data from the device's host microcontroller's CMOS logic-level serial port is packetized and delivered over an Ethernet network via TCP or UDP data packets. Similarly, incoming TCP or UDP packets are packaged and sent to the attached device over its microcontroller's serial interface. This enables OEMs to use less expensive, less powerful host microcontrollers on their products without sacrificing performance.

Feature-rich, Royalty-free Application and Network Protocol Firmware

XChip comes with a robust, licensed networking and applications firmware binary, so virtually zero programming is required. Powered

by the same firmware already deployed in millions of networked nodes, this networking co-processor makes it easy to design-in connectivity and significantly speed time-to-market. The application-ready networking firmware and a feature-rich network protocol stack includes TCP/IP, UDP, BootP, DHCP and AutoIP. It also features a variety of configurable options for serial-to-Ethernet tunneling (baud rate, flow control, port number, data packing control intervals, inactivity timeout and MTU size). It can trigger email alerts on in-band serial data patterns or configurable pins inputs. Optional 256-bit AES (Rijndael) end-to-end encryption is available.

Ideal for High-Volume Applications

With its low cost, small size and powerful feature set, XChip is an ideal solution for high-volume, cost sensitive products.

- Consumer electronics
- Energy/metering applications
- Point of sale (POS) products
- White/durable goods
- Building automation (lighting, etc.)
- Home automation (high-end audio, alarm panels, etc.)
- RFID readers
- Sensors and controllers
- Vending machines

Complete Hardware Reference Design Package

XChip comes complete with a compact, 4-layer reference design optimized for cost, compliance and performance.

- Gerber Files (RS-274-X)
- PADS PCB design file (PADS2005 Spac 2)
- Schematic and assembly diagram (PDF and DSN)
- Fabrication drawing
- Design Integration Guide

Additional Software Utilities for Easy Configuration & Network Deployment

Deploying products in volume on a network typically require additional Windows software to simplify implementation. Dynamic Host Protocol Support (DHCP) and additional IP configuration methods included with XChip's Windows®-based DeviceInstaller™ software streamline device deployment and network initiation.

Additionally, the included Com Port Redirector™ (CPR) software maps “virtual COM” ports on a PC platform and redirects application data destined for an attached device. Rather than going out the local COM port, the data is transmitted across the Ethernet network to and from the XChip using TCP/IP.





Features

Architecture

- CPU: x86 architecture
- Memory: 256 KB on-chip SRAM (No external RAM required)
- Ethernet MAC/PHY: 10-100, integrated inside the CPU

Electrical Characteristics:

- 1.8VDC core supply voltage
- 3.3 VDC I/O supply voltage

Serial Interface

- Data Rates: 300 bps to 921,600 bps
- Characters: 7 or 8 data bits
- Parity: odd, even, none
- Stop Bits: 1 or 2
- Control Signals: DTR/DCD, CTS, RTS
- Flow Control: XON/XOFF, RTS/CTS

Programmable I/O:

- 3 PIO pins (software selectable)

Network Interface

- Interface: Ethernet 10Base-T or 100Base-TX (Using external RJ45 Jack)

Packaging

- 184 BGA, 12mm x 12mm, RoHS Compliant

Environmental

- Operating: -40° to 85°C (-40° to 185°F)
- Storage: -40° to 85°C (-40° to 185°F)

Firmware (Licensed with XChip)

- Network Protocols: TCP/IP, UDP/IP, ARP, ICMP, SNMP, TFTP, Telnet, server DHCP, BOOTP, HTTP and AutoIP
- Web Server: Web server with Java support Customizable/brandable
- Web Page Storage capacity: 384KB (Uses a portion of the 512 KB External Flash)
- SMTP Email Management: Internal web server, SNMP, Serial login, Telnet login
- Serial to Ethernet (LAN) Application

Data Security

- Optional 256-bit AES Rijndael encryption (Different Firmware Load)

Software Utilities (Licensed with XChip)

- DeviceInstaller software
- COM Port Redirector

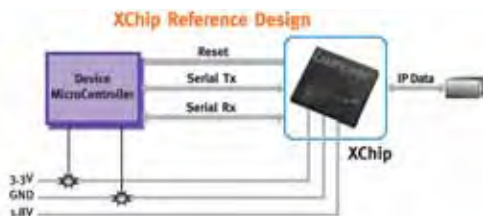

XChip Layout and Included Software

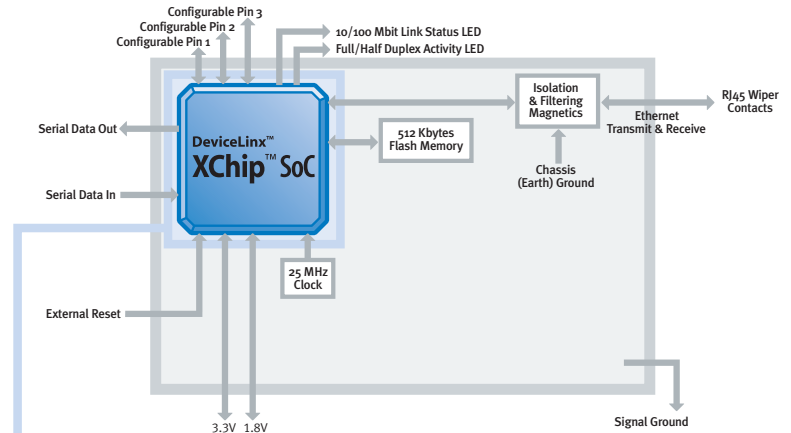

Note: OEM supplies Flash Memory, RJ45-Magnetics, Clock crystal and regulated power inputs.

APPLICATIONS	TUNNELING	3RD PARTY CUSTOMIZATION				
APPLICATIONS SUPPORT	WEB MANAGER	CONFIGURATION STORE				
SECURITY	AES	PACKET FILTER				
NETWORK	UDP	HTTP	CGI	DNS	MIB II	
	TCP	ICMP	PPP	TFTP	DISCOVERY	SNMP
	IP	ARP	AUTO-IP	BOOTP	DHCP	
DRIVERS	FLASH DRIVER	WATCH DOG	EEPROM			
	ETHERNET	SERIAL LINES	PIO (CP) DRIVER			
KERNEL	TASKING MODULE	MEMORY (HEAP) MODULE	TIMERS			

Reference Design

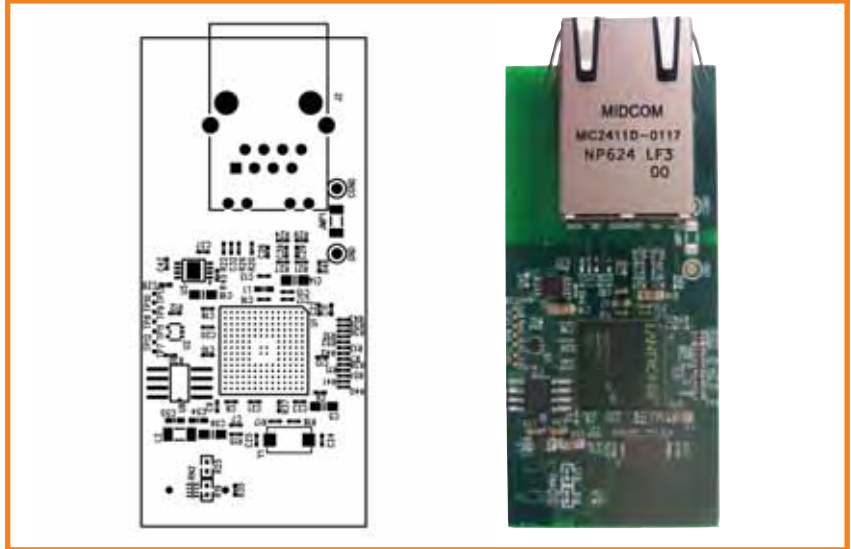

Ordering Information

Part Number	Description
XCP1001000-01	XChip Embedded Device Server SoC Co-processor, 184 Pin BGA, Bulk
XCP100100S-01	XChip Embedded Device Server SoC Co-processor, 184 Pin BGA, Sample
XCP100100K-01	XChip Embedded Device Server SoC Co-processor, 184 Pin BGA, Kit



15353 Barranca Parkway | Irvine | CA 92618 | USA | Tel: 949.453.3990 | Fax: 949.453.3995 | www.lantronix.com

© 2007 Lantronix, Inc. Lantronix and XPort are registered trademarks and Com Port Redirector, DeviceInstaller, XChip and DeviceLinX are trademarks of Lantronix. All other trademarks are the property of their respective owners. Specifications subject to change without notice. All rights reserved. 910-489 09/07 DGS2500