



## XChip Direct SoC – Network Connectivity on a Chip

- ▶ Connects to host microcontroller for serial to Ethernet (LAN) applications
- ▶ Robust networking and applications firmware included – no coding required; zero royalty licensing agreement
- ▶ Integrated 10-100 MAC/PHY; 256K SRAM; up to 230 Kbps data rate
- ▶ Compact 12mm x 12mm 184 BGA RoHS compliant package



## Affordable Serial to Ethernet Connectivity in a Deployment-Ready Chip

A member of the DeviceLinX™ XChip™ family of networking system-on-chip solutions, the XChip Direct™ SoC rapidly delivers highly-affordable and field-proven Ethernet (IP) connectivity to virtually any electronic product with a serial interface on its host microcontroller. In designs where embedded web server capability is not required, XChip Direct delivers the SoC bundled with application and networking firmware for the same level of Ethernet connectivity as the market-proven XPort® Direct device networking module.

### Highly-integrated Networking Processor SoC

Fabricated using an industry-standard CMOS process, XChip Direct is a highly-integrated x86-class processor that includes a built in Ethernet MAC and 10-100 PHY, 256 KB zero wait-state SRAM, up to 2 GPIOs and a high-performance serial UART in a compact 12mm x 12mm 184 BGA RoHS-compliant, industrial temperature package.

Simply connect the serial port to the XChip Direct and load the Lantronix supplied royalty free standard application and network protocol firmware in an external Flash chip. Finish by adding an RJ45 jack and magnetics to instantly connect virtually any product to an Ethernet network or the Internet!

A dedicated networking co-processor, it enables the host microcontroller to function at maximum capacity without the burden of network processing overhead. Serial data from the device microcontroller's CMOS logic-level serial port is packetized and delivered over an Ethernet network via TCP or UDP data packets. Similarly, incoming TCP or UDP packets are packaged and sent to the attached device over its microcontroller's serial interface. This enables OEMs to use less expensive, less powerful host microcontrollers on their products without sacrificing performance.

### Feature-rich, Royalty-free Application and Network Protocol Firmware

XChip Direct comes with robust, licensed networking firmware so virtually zero programming is required. Powered by the same firmware already deployed in millions of networked nodes,

this processor makes it easy to design-in connectivity and significantly speed time-to-market. The application-ready networking firmware and a feature-rich network protocol stack includes TCP/IP, UDP, BootP, DHCP and AutoIP.

It also features a variety of configurable options for serial-to-Ethernet tunneling (baud rate, flow control, port number, data packing control intervals, inactivity timeout and MTU size).

### Ideal for High-Volume Applications

With its low cost, small size and potent functionality, XChip Direct is an ideal solution for high-volume, cost sensitive products.

- Consumer electronics
- Building automation (lighting, etc.)
- Energy/metering applications
- Home automation (high-end audio, alarm panels, etc.)
- Point of sale (POS) products
- RFID readers
- Sensors and controllers
- Vending machines
- White/durable goods

### Complete Hardware Reference Design Package

XChip Direct comes complete with a compact, 4-layer reference design optimized for cost and performance.

- Gerber Files (RS-274-X)
- PADS PCB design file (PADS2005 Spac 2)
- Fabrication drawing
- Design Integration Guide
- Schematic and assembly diagram (PDF and DSN)

### Additional Software Utilities for Easy Configuration and Deployment

Deploying products in volume on a network typically require additional Windows software to simplify implementation. Dynamic Host Protocol Support (DHCP) and additional IP configuration methods included with XChip Direct's Windows®-based DeviceInstaller™ software streamline device deployment and network initiation.

Additionally, the included Com Port Redirector™ (CPR) software maps "virtual COM" ports on a PC platform and redirects application data destined for an attached device. Rather than going out the local COM port, the data is transmitted across the Ethernet network to and from the XChip Direct using TCP/IP.





### Features

#### Architecture

- CPU: x86 architecture
- Memory: 256 KB on-chip SRAM (No external RAM required)
- Ethernet MAC/PHY: 10-100, integrated inside the CPU

#### Electrical Characteristics:

- 1.8VDC core supply voltage
- 3.3 VDC I/O supply voltage

#### Serial Interface

- Data Rates: 300 bps to 230 Kbps
- Characters: 7 or 8 data bits
- Parity: odd, even, none
- Stop Bits: 1 or 2
- Control Signals: DTR/DCD, CTS,RTS
- Flow Control: XON/XOFF, RTS/CTS

#### Programmable I/O:

- 2 PIO pins (software selectable)

#### Network Interface

- Interface: Ethernet 10Base-T or 100Base-TX (Using external RJ45 Jack)

#### Packaging

- 184 BGA, 12mm x 12mm, RoHS

#### Environmental

- Operating: -40° to 85°C (-40° to 185°F)
- Storage: -40° to 85°C (-40° to 185°F)

#### Firmware (Licensed with XChip Direct)

- Network Protocols: TCP/IP, UDP/IP, ARP, ICMP, SNMP, TFTP, Telnet, DHCP, BOOTP and AutoIP
- Serial to Ethernet (LAN) Tunneling Application

#### Software Utilities (Licensed with XChip Direct)

- DeviceInstaller software
- COM Port Redirector

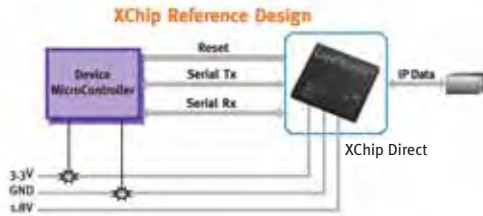

## XChip Direct Layout and Included Software

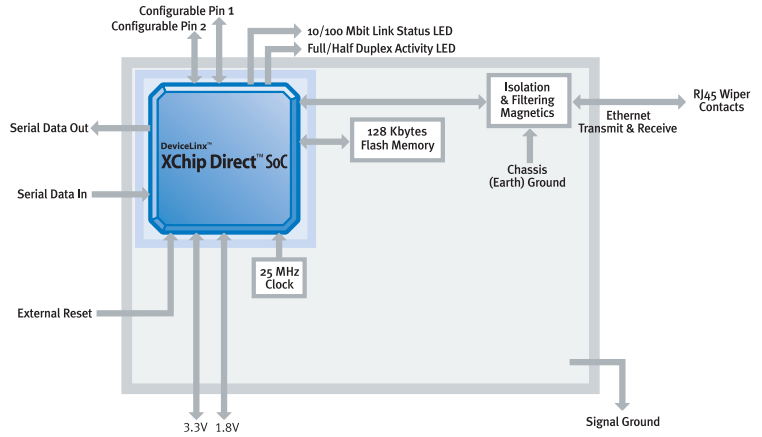

Note: OEM supplies Flash Memory, RJ45-Magnetics, Clock crystal and regulated power inputs.

APPLICATIONS	TUNNELING		
APPLICATIONS SUPPORT	FILE SYSTEM	GPIO MANAGER	CONFIGURATION STORE
SECURITY	PACKET FILTER		
NETWORK	UDP	TCP	CGI
	ICMP	PPP	TFTP
	IP	ARP	AUTO-IP
DRIVERS	FLASH DRIVER	WATCH DOG	EEPROM
	ETHERNET	SERIAL LINES	PIO (CP) DRIVER
KERNEL	TASKING MODULE	MEMORY (HEAP) MODULE	TIMERS

## Reference Design

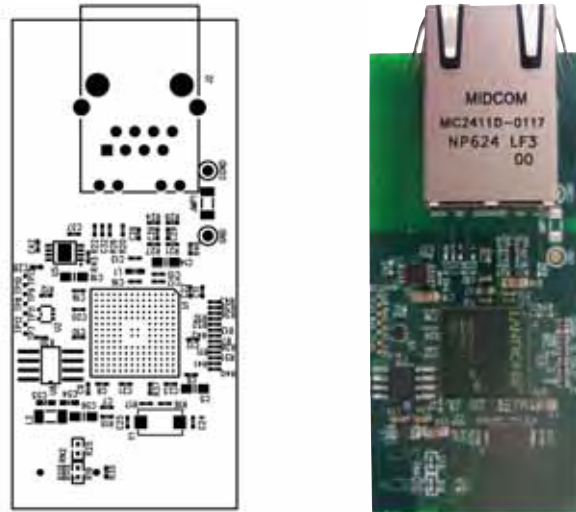

## Ordering Information

Part Number	Description
XCD1001000-01	XChip Direct Embedded Device Gateway SoC Co-Processor, 184 Pin BGA, Bulk
XCD100100S-01	XChip Direct Embedded Device Gateway SoC Co-Processor, 184 Pin BGA, Sample
XCD100100K-01	XChip Direct Embedded Device Gateway SoC Co-Processor, 184 Pin BGA, Kit



15353 Barranca Parkway | Irvine | CA 92618 | USA | Tel: 949.453.3990 | Fax: 949.453.3995 | [www.lantronix.com](http://www.lantronix.com)

©2007 Lantronix, Inc. Lantronix and XPort are registered trademarks and Com Port Redirector, DeviceInstaller, XChip Direct and DeviceLinX are trademarks of Lantronix. All other trademarks are the property of their respective owners. Specifications subject to change without notice. All rights reserved. 910-529 09/07 DGS2500