



MAXADClite+ Evaluation Kit

General Description

The MAXADClite evaluation kit (EV kit) evaluates the MAX11645, Maxim's smallest, very-low-power, 12-bit, 2-channel analog-to-digital converter (ADC). The EV kit allows usage of the ADC's internal reference or an externally applied reference voltage.

The EV kit includes Windows XP®, Windows Vista®, and Windows® 7-compatible software for data acquisition through a USB cable.

EV Kit Contents

The EV kit comes with the following components:

- MAXADClite+ evaluation board
- USB cable
- MAXADClite+ GUI application

Features

- ◆ Windows XP-, Windows Vista-, and Windows 7-Compatible Software
- ◆ USB-PC Connection (Cable Included)
- ◆ USB Powered (No External Power Supply Required)
- ◆ Real-Time Data Acquisition Through the USB

Ordering Information

PART	TYPE
MAXADClite+	EV Kit

+Denotes lead(Pb)-free and RoHS compliant.

Component List

DESIGNATION	QTY	DESCRIPTION
C1-C4	4	18pF ±5%, 50V ceramic capacitors (0603)
C5, C7, C8, C9	4	1µF ±10%, 16V ceramic capacitors (0603)
C6, C10-C14	6	0.1µF ±10%, 50V ceramic capacitors (0603)
J1	1	Mini-USB type-B receptacle
J2	0	Not installed, 10-pin JTAG connector
J3	1	4-pin header, 100 mill centers
J4, J5, J6	0	Not installed, 2-pin headers
R1, R2	2	27Ω ±5% resistors (0603)
R3, R4	2	4.7kΩ ±5% resistors (0603)
R5	1	10kΩ ±5% resistor (0603)
R6	0	Not installed, resistor (0603)
R7, R8	2	499kΩ ±5% resistors (0603)

DESIGNATION	QTY	DESCRIPTION
R9, R10	2	0Ω resistors (0603)
R11-R15	0	Not installed, resistors (0402)
U1	1	12-bit ADC with internal reference (12 WLP) Maxim MAX11645EWC+
U2	1	Low-power, 16-bit RISC microcontroller) (40 TQFN-EP*) Maxim MAXQ610B-0000+
U3	1	USB peripheral controller with SPI interface (24 TQFN-EP*) Maxim MAX3420EETG+
U4	1	Ultra-low-noise, high-PSRR LDO linear regulator (5 SC70) Maxim MAX8511EXK33+
Y1, Y2	2	12MHz crystals
—	1	PCB: MAXADClite+

*EP = Exposed pad.

Windows, Windows XP, and Windows Vista are registered trademarks of Microsoft Corp.



Maxim Integrated Products 1

For pricing, delivery, and ordering information, please contact Maxim Direct at 1-888-629-4642, or visit Maxim's website at www.maxim-ic.com.

Evaluates: MAX11645

MAXADClite+ Evaluation Kit

Quick Start

The MAXADClite+ EV kit board is a plug-n-play data-acquisition kit that connects to the PC through a USB cable. The EV kit digitizes two different analog inputs and does not require an external power supply or a USB device driver. The EV kit is preloaded with default firmware that communicates with the MAXADClite+ evaluation software. Software can be installed and run on any Windows-based system.

Note: In the following sections, software-related items are identified by bolding. Text in **bold** refers to items directly from the EV kit software. Text in **bold and underlined** refers to items from the Windows operating system.

Procedure

The EV kit is fully assembled and tested. Follow the steps below to acquire data through the EV kit:

- 1) Connect the EV kit board to a PC through the USB cable. The EV kit board receives power from the USB.

- 2) Connect the analog input(s) at AIN0 or AIN1 and AGND at J3. See Table 1 for more details.
- 3) Install and run the MAXADClite+ GUI application.
- 4) Once the status bar displays **Hardware connected**, select the **Device Configuration** options for internal or external reference, input channel, single-ended or differential measurement, and unipolar or bipolar measurement. Next, select the **Number of Samples** from the **Data Logging** group box drop-down list. Once all options are set, press the **Start Conversion** button to proceed (Figure 1).

Table 1. MAXADClite+ Connector J3 Description

J3 PIN NO.	LABEL	FUNCTION
1	AVDD	3.3V, 100mA supply for external circuit
2	AIN0	ADC input to channel 0
3	AIN1	ADC input to channel 1
4	AGND	Analog ground pin



Figure 1. MAXADClite+ GUI Application

MAXADClite+ Evaluation Kit

Evaluates: MAX11645

Detailed Description of Hardware

The MAXADClite+ EV kit board is loaded with the MAX11645, Maxim's smallest, lowest power, 12-bit ADC. The ADC communicates through an I2C interface to the 16-bit RISC MAXQ610 microcontroller. This microcontroller communicates to the PC through an SPI-USB peripheral controller (Figure 2).

The EV kit microcontroller is preloaded with firmware that communicates with the EV kit GUI application. Upon receiving the login command from the GUI, it acquires data from the ADC over the I2C bus and sends it to the PC for display and further analysis.

MAXADClite+ Extended Features

- The ADC on the EV kit board can be selected for internal or external reference mode. The internal 2.048V reference is the default configuration. The

external reference mode can be selected through software. Apply an external voltage between 1V and VDD at J5 (see Table 2).

- The input range of the EV kit software is selectable between a unipolar 0 to VREF or $\pm VREF/2$ differential range. The input type is also software selectable between two single-ended inputs or one differential input. The default input configuration is single-ended unipolar. In differential mode, the input needs to be connected on both the analog inputs (AIN0 and AIN1) on J3. Refer to the MAX11644/MAX11645 IC data sheet for more information.
- The EV kit board provides an external 5V supply at J6 to be used with any external circuit (see Table 3).
- The microcontroller on the EV kit board can also be programmed with custom firmware through the J2 JTAG connector (see Table 4).

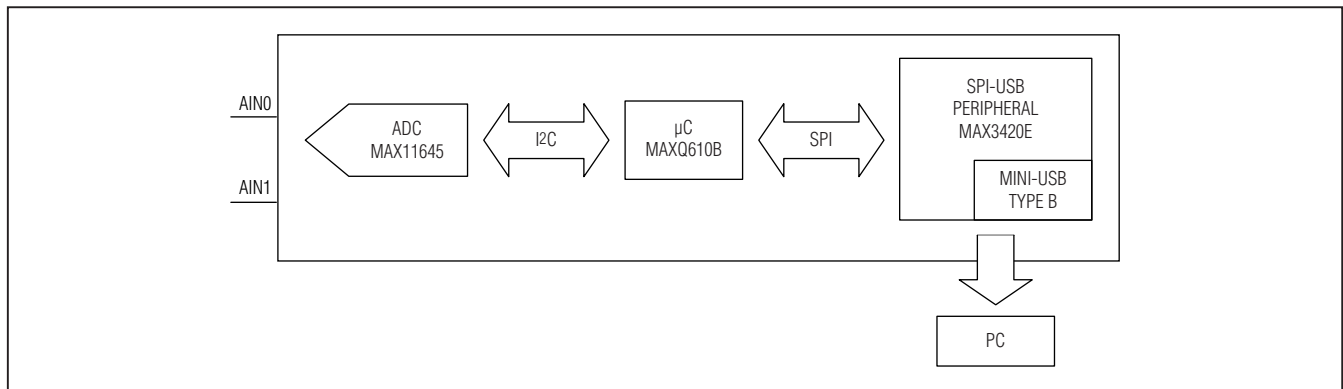

Figure 2. MAXADClite+ Block Diagram

Table 2. MAXADClite+ Connector J5 Description

J5 PIN NO.	LABEL	FUNCTION
1	VREF	External reference voltage input to the ADC
2	AGND	Analog ground pin

Table 3. MAXADClite+ Connector J6 Description

J6 PIN NO.	LABEL	FUNCTION
1	VUSB	5V, 300mA supply for the external circuit
2	GND	Digital ground pin

Table 4. MAXADClite+ Connector J2 Description

J2 PIN NO.	LABEL	FUNCTION
1	TCK	Test clock
2	GND	Digital ground pin
3	TDO	Test data output
4	+3V3	Supply voltage for reference only
5	TMS	Test mode select
6	RST	MAXQ610 microcontroller reset pin
7	N.C.	No connect
8	VUSB*	5V supply for the JTAB debug adapter
9	TDI	Test data input
10	GND	Digital ground pin

*Not directly connected to VUSB. Shunt J4 is for VUSB.

MAXADClite+ Evaluation Kit

Evaluates: MAX11645

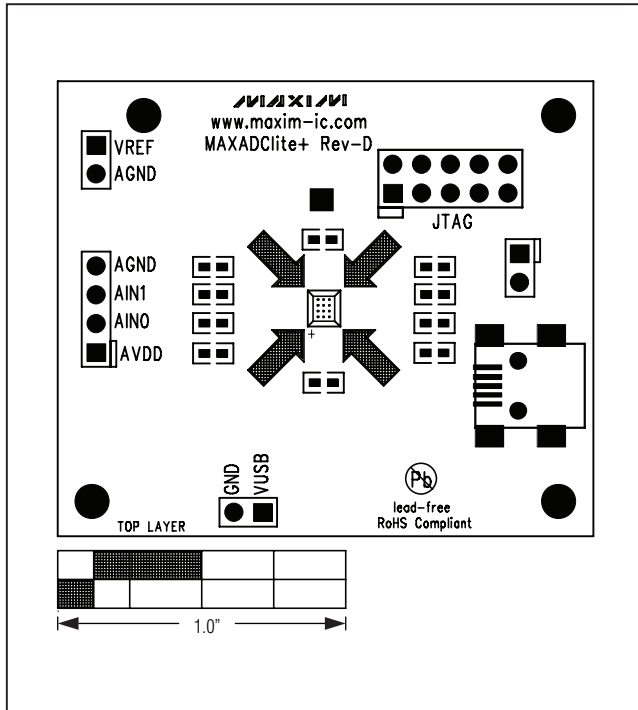

Figure 4. MAXADClite+ Component Placement Guide—Component Side

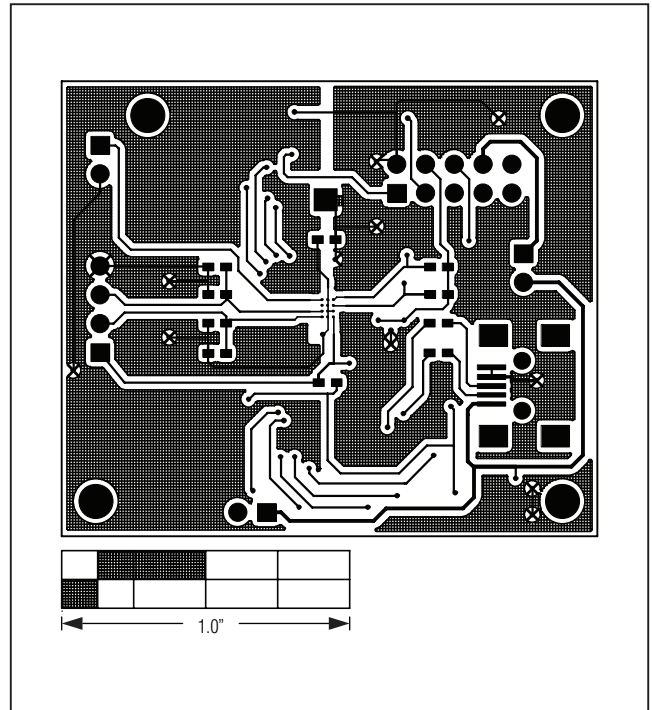

Figure 6. MAXADClite+ PCB Layout—Component Side

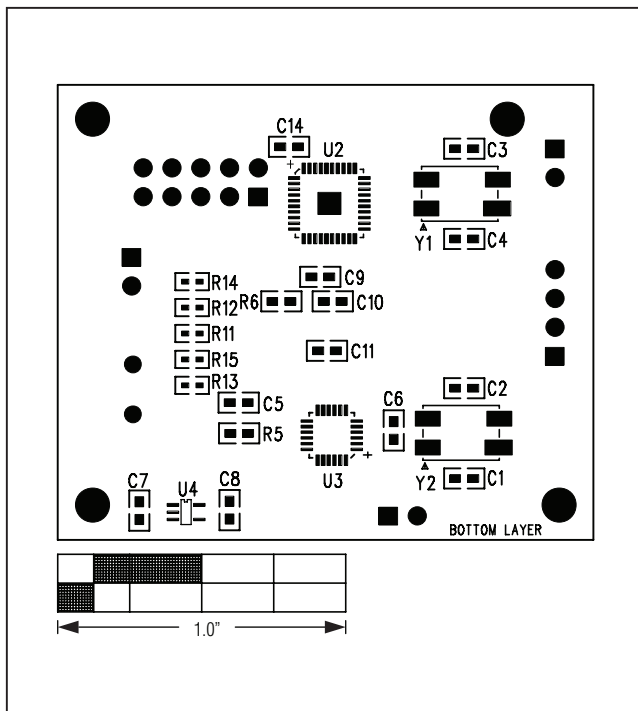

Figure 5. MAXADClite+ Component Placement Guide—Solder Side

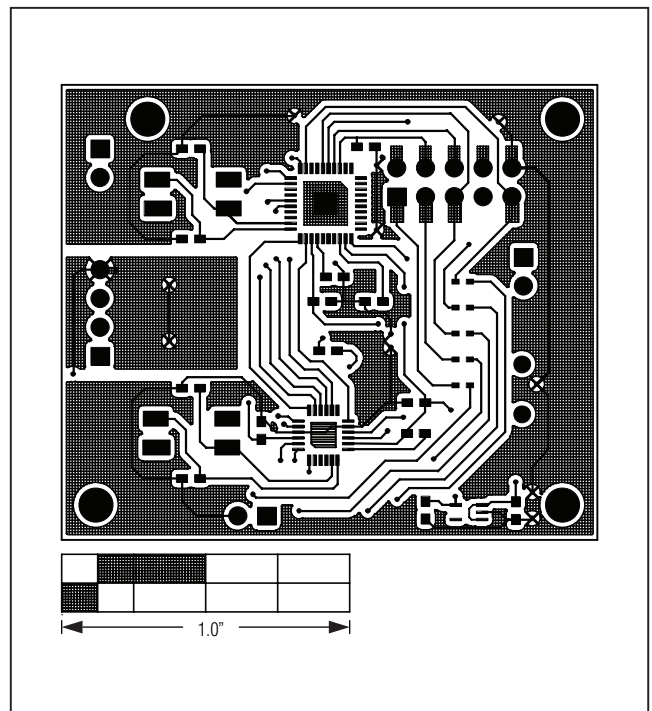

Figure 7. MAXADClite+ PCB Layout—Solder Side

MAXADClite+ Evaluation Kit

Evaluates: MAX11645

Revision History

REVISION NUMBER	REVISION DATE	DESCRIPTION	PAGES CHANGED
0	10/10	Initial release	—

Maxim cannot assume responsibility for use of any circuitry other than circuitry entirely embodied in a Maxim product. No circuit patent licenses are implied. Maxim reserves the right to change the circuitry and specifications without notice at any time.

6 _____ **Maxim Integrated Products, 120 San Gabriel Drive, Sunnyvale, CA 94086 408-737-7600**

© 2010 Maxim Integrated Products

Maxim is a registered trademark of Maxim Integrated Products, Inc.