

## MULTICHANNEL DIGITAL AUDIO PROCESSOR WITH DDX™

- 8 DDX™ Channels Capability (24 bit)
- From 32kHz to 192kHz Input Sample Rates Supported
- Volume Control from 0 to -127 dB (0.5 dB steps)
- Variable Digital Gain from 0 to 24dB (0.5dB steps) with Digital Limiter Functionality and Variable Attack and Release Time
- I<sup>2</sup>S Inputs and Outputs
- Individual Channel and Master Gain/Attenuation
- Individual Channel Mute and Zero Input Detect Auto-Mute
- Selectable Serial Audio Data Interface
- Bass/Treble Controls
- Channel Mapping of any Input to any Processing/DDX™ Channel
- Active Crossover Capability
- DC Blocking Selectable High-Pass Filter
- Selectable Bass Management on Channel 6
- Selectable Adjacent Channel Mixing Capability
- Selectable DDX™ Headphone Output on Channels 7 & 8
- Selectable Clock Input Ratio
- Selectable De-emphasis
- Selectable DDX™ Ternary, or Binary PWM output
- AM Interference Reduction Mode
- I<sup>2</sup>C Control

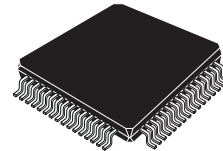

**TQFP64**  
**ORDERING NUMBER: STA308**

### DESCRIPTION

The STA308 is a single chip solution for digital audio processing and control in multi-channel applications. It provides output capabilities for DDX™ (Direct Digital Amplification). In conjunction with a DDX™ power device, it provides high-quality, high-efficiency, all digital amplification. The device is extremely versatile allowing for input of most digital formats including 6.1 channel and 192kHz, 24-bit DVD-Audio.

The internal 24-bit DSP allows for high resolution processing at all standard input sample frequencies. Processing includes volume control, filtering, bass management, gain compression/limiting and PCM and DDX™ outputs. Filtering includes five user-programmable 28-bit biquads for EQ per channel, as well as bass, treble and DC blocking. External clocking can be provided at 4 different ratios of the input sample frequency. All sample frequencies are up-sampled for processing. Each internal processing channel can receive any input channel, allowing flexibility and the ability to perform active digital crossover for powered loudspeaker systems.

The serial audio data interface accepts many different formats, including the popular I<sup>2</sup>S format. Eight channels of DDX processing are performed.

BLOCK DIAGRAM

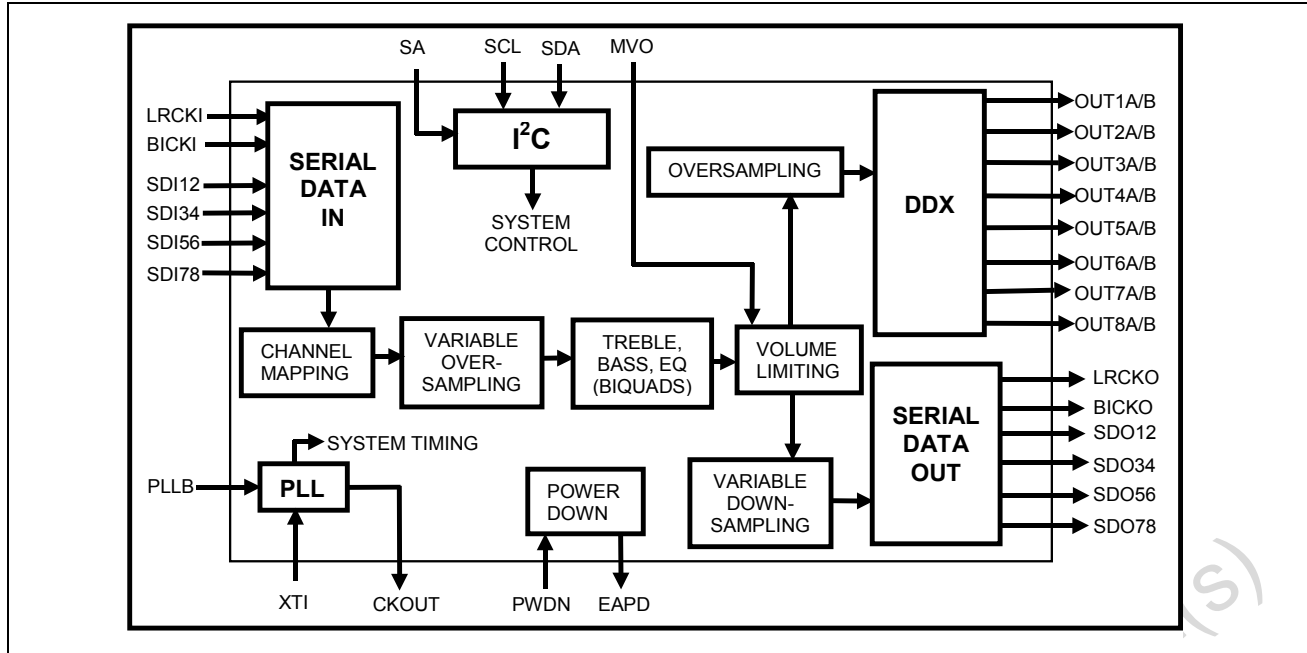
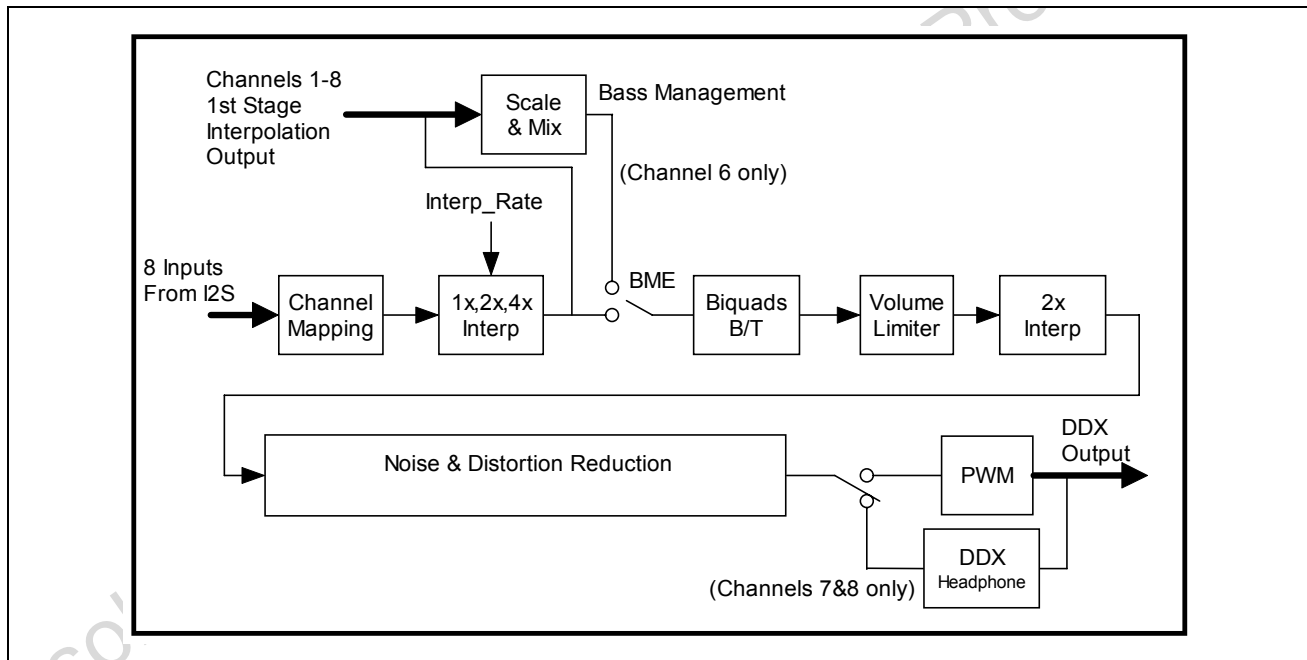
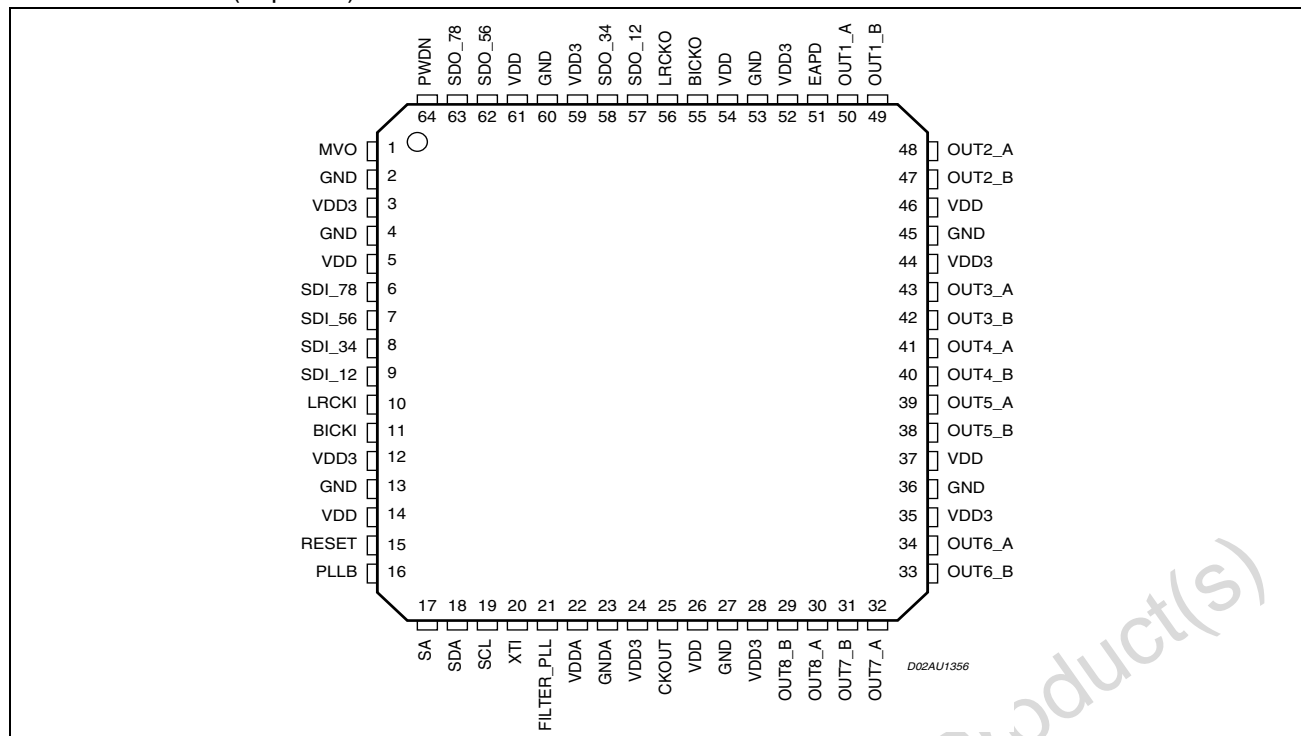

Figure 1. Signal Flow Diagram



IN CONNECTION (Top view)



PIN FUNCTION

| PIN                           | NAME   | TYPE | DESCRIPTION                          | PAD TYPE   |
|-------------------------------|--------|------|--------------------------------------|--|
| 1                             | MVO    | I    | Master Volume Override               | CMOS Input Buffer with Pull-Down   |
| 3, 12, 24, 28, 35, 44, 52, 59 | VDD3   |      | 3.3V Digital Supply                  | 3.3V Digital Power Supply Voltage (pad ring)   |
| 2, 4, 13, 27, 36, 45, 53, 60  | GND    |      | Digital Ground                       | Digital Ground   |
| 5, 14, 26, 37, 46, 54, 61     | VDD    |      | 2.5V Digital Supply                  | 2.5V Digital Power Supply Voltage (core + ring)  |
| 6                             | SDI_78 | I    | Input I2S Serial Data Channels 7 & 8 | 5V Tolerant TTL Input Buffer   |
| 7                             | SDI_56 | I    | Input I2S Serial Data Channels 5 & 6 | 5V Tolerant TTL Input Buffer   |
| 8                             | SDI_34 | I    | Input I2S Serial Data Channels 3 & 4 | 5V Tolerant TTL Input Buffer   |
| 9                             | SDI_12 | I    | Input I2S Serial Data Channels 1 & 2 | 5V Tolerant TTL Input Buffer   |
| 10                            | LRCKI  | I    | Inputs I2C Left/Right Clock          | 5V Tolerant TTL Input Buffer   |
| 11                            | BICKI  | I    | Inputs I2C Serial Clock              | 5V Tolerant TTL Input Buffer   |
| 15                            | RESET  | I    | Global Reset                         | 5V Tolerant TTL Schmitt Trigger Input Buffer   |
| 16                            | PLLB   | I    | PLL Bypass                           | CMOS Input Buffer with Pull-Down   |
| 17                            | SA     | I    | Select Address (I2C)                 | CMOS Input Buffer with Pull-Down   |
| 18                            | SDA    | I/O  | I2C Serial Data                      | Bidirectional Buffer:<br>5V Tolerant TTL Schmitt Trigger Input;<br>3.3V Capable 2 mA Slew-rate control Output; |
| 19                            | SCL    | I    | I2C Serial Clock                     | 5V Tolerant TTL Schmitt Trigger Input Buffer   |

## PIN FUNCTION (continued)

| PIN | NAME       | TYPE | DESCRIPTION                            | PAD TYPE                                       |
|-----|------------|------|--|--|
| 20  | XTI        | I    | Crystal Oscillator Input (Clock Input) | 3.3V Tolerant TTL Schmitt Trigger Input Buffer |
| 21  | FILTER_PLL |      | PLL Filter                             | Analog Pad                                     |
| 22  | VDDA       |      | PLL 2.5V Supply                        | 2.5V Analog Power Supply Voltage               |
| 23  | GND_A      |      | PLL Ground                             | Analog Ground                                  |
| 25  | CKOUT      | O    | Clock Output                           | 3.3V Capable TTL Tristate 4mA Output Buffer    |
| 29  | OUT8_B     | O    | PWM Channel 8 Output B                 | 3.3V Capable TTL 2mA Output Buffer             |
| 30  | OUT8_A     | O    | PWM Channel 8 Output A                 | 3.3V Capable TTL 2mA Output Buffer             |
| 31  | OUT7_B     | O    | PWM Channel 7 Output B                 | 3.3V Capable TTL 2mA Output Buffer             |
| 32  | OUT7_A     | O    | PWM Channel 7 Output A                 | 3.3V Capable TTL 2mA Output Buffer             |
| 33  | OUT6_B     | O    | PWM Channel 6 Output B                 | 3.3V Capable TTL 2mA Output Buffer             |
| 34  | OUT6_A     | O    | PWM Channel 6 Output A                 | 3.3V Capable TTL 2mA Output Buffer             |
| 38  | OUT5_B     | O    | PWM Channel 5 Output B                 | 3.3V Capable TTL 2mA Output Buffer             |
| 39  | OUT5_A     | O    | PWM Channel 5 Output A                 | 3.3V Capable TTL 2mA Output Buffer             |
| 40  | OUT4_B     | O    | PWM Channel 4 Output B                 | 3.3V Capable TTL 2mA Output Buffer             |
| 41  | OUT4_A     | O    | PWM Channel 4 Output A                 | 3.3V Capable TTL 2mA Output Buffer             |
| 42  | OUT3_B     | O    | PWM Channel 3 Output B                 | 3.3V Capable TTL 2mA Output Buffer             |
| 43  | OUT3_A     | O    | PWM Channel 3 Output A                 | 3.3V Capable TTL 2mA Output Buffer             |
| 47  | OUT2_B     | O    | PWM Channel 2 Output B                 | 3.3V Capable TTL 2mA Output Buffer             |
| 48  | OUT2_A     | O    | PWM Channel 2 Output A                 | 3.3V Capable TTL 2mA Output Buffer             |
| 49  | OUT1_B     | O    | PWM Channel 1 Output B                 | 3.3V Capable TTL 2mA Output Buffer             |
| 50  | OUT1_A     | O    | PWM Channel 1 Output A                 | 3.3V Capable TTL 2mA Output Buffer             |
| 51  | EAPD       | O    | External Amplifier Power Down          | 3.3V Capable TTL 2mA Output Buffer             |
| 55  | BICKO      | O    | Output I2S Serial Clock                | 3.3V Capable TTL 2mA Output Buffer             |
| 56  | LRCKO      | O    | Output I2S Left/Right Clock            | 3.3V Capable TTL 2mA Output Buffer             |
| 57  | SDO_12     | O    | Output I2S Serial Data Channels 1 & 2  | 3.3V Capable TTL 2mA Output Buffer             |
| 58  | SDO_34     | O    | Output I2S Serial Data Channels 3 & 4  | 3.3V Capable TTL 2mA Output Buffer             |
| 62  | SDO_56     | O    | Output I2S Serial Data Channels 5 & 6  | 3.3V Capable TTL 2mA Output Buffer             |
| 63  | SDO_78     | O    | Output I2S Serial Data Channels 7 & 8  | 3.3V Capable TTL 2mA Output Buffer             |
| 64  | PWDN       | I    | Device Powerdown                       | 5V Tolerant TTL Schmitt Trigger Input Buffer   |

**ABSOLUTE MAXIMUM RATINGS**

| Symbol              | Parameter                     | Value                          | Unit |
|---------------------|-------------------------------|--------------------------------|------|
| V <sub>DD_3.3</sub> | 3.3V I/O Power Supply         | -0.5 to 4                      | V    |
| V <sub>DD_2.5</sub> | 2.5V Logic Power Supply       | -0.5 to 3.3                    | V    |
| V <sub>i</sub>      | Voltage on input pins         | -0.5 to (V <sub>DD</sub> +0.5) | V    |
| V <sub>o</sub>      | Voltage on output pins        | -0.5 to (V <sub>DD</sub> +0.3) | V    |
| T <sub>stg</sub>    | Storage Temperature           | -40 to +150                    | °C   |
| T <sub>amb</sub>    | Ambient Operating Temperature | -20 to +85                     | °C   |

**THERMAL DATA**

| Symbol               | Parameter                              | Value | Unit |
|----------------------|--|-------|------|
| R <sub>thj-amb</sub> | Thermal resistance Junction to Ambient | 85    | °C/W |

**RECOMMENDED DC OPERATING CONDITIONS**

| Symbol              | Parameter                      | Value       | Unit |
|---------------------|--------------------------------|-------------|------|
| V <sub>DD_3.3</sub> | I/O Power Supply               | 3.0 to 3.6  | V    |
| V <sub>DD_2.5</sub> | Logic Power Supply             | 2.3 to 2.7  | V    |
| T <sub>j</sub>      | Operating Junction Temperature | -20 to +125 | °C   |

**ELECTRICAL CHARACTERISTICS** ( $V_{DD3} = 3.3V \pm 0.3V$ ;  $V_{DD} = 2.5V \pm 0.2V$ ;  $T_{amb} = 0$  to  $70\text{ }^{\circ}\text{C}$ ; unless otherwise specified)

**GENERAL INTERFACE ELECTRICAL CHARACTERISTICS**

| Symbol    | Parameter                                   | Test Condition           | Min. | Typ. | Max. | Unit          | Note |
|-----------|---|--------------------------|------|------|------|---------------|------|
| $I_{il}$  | Low Level Input no pull-up                  | $V_i = 0V$               |      |      | 1    | $\mu\text{A}$ | 1    |
| $I_{ih}$  | High Level Input no pull-down               | $V_i = V_{DD3}$          |      |      | 2    | $\mu\text{A}$ | 1    |
| $I_{OZ}$  | Tristate output leakage without pullup/down | $V_i = V_{DD3}$          |      |      | 2    | $\mu\text{A}$ | 1    |
| $V_{esd}$ | Electrostatic Protection                    | Leakage $< 1\mu\text{A}$ | 1000 |      |      | V             | 2    |

Note 1: The leakage currents are generally very small,  $< 1\text{na}$ . The values given here are maximum after an electrostatic stress on the pin.  
 Note 2: Human Body Model; except for  $V_{DD}$  pins vs GND that sustain 100V

**DC ELECTRICAL CHARACTERISTICS: 3.3V BUFFERS**

| Symbol       | Parameter                  | Test Condition                                       | Min.                 | Typ. | Max. | Unit   |
|--------------|----------------------------|--|----------------------|------|------|--------|
| $V_{IL}$     | Low Level Input Voltage    |  |                      |      | 0.8  | V      |
| $V_{IH}$     | High Level Input Voltage   |  | 2.0                  |      |      | V      |
| $V_{ILhyst}$ | Low Level Threshold        | Input Falling  | 0.8                  |      | 1.35 | V      |
| $V_{IHhyst}$ | High Level Threshold       | Input Rising   | 1.3                  |      | 2.0  | V      |
| $V_{hyst}$   | Schmitt Trigger Hysteresis |  | 0.3                  |      | 0.8  | V      |
| $V_{ol}$     | Low Level Output           | $I_{ol} = 100\mu\text{A}$                            |                      |      | 0.2  | V      |
| $V_{oh}$     | High Level Output          | $I_{oh} = -100\mu\text{A}$<br>$I_{oh} = -2\text{mA}$ | $V_{DD3}-0.2$<br>2.4 |      |      | V<br>V |

**DC ELECTRICAL CHARACTERISTICS: 2.5V BUFFERS**

| Symbol       | Parameter                  | Test Condition             | Min.                | Typ.               | Max.                | Unit |
|--------------|----------------------------|----------------------------|---------------------|--------------------|---------------------|------|
| $V_{ILst}$   | Low Level Input Voltage    | Schmitt input              |                     |                    | $0.26 \cdot V_{DD}$ | V    |
| $V_{IHst}$   | High Level Input Voltage   | Schmitt input              | $0.7 \cdot V_{DD}$  |                    |                     | V    |
| $V_{ILhyst}$ | Low Level Threshold        | non Schmitt, Input Falling |                     | $0.5 \cdot V_{DD}$ |                     | V    |
| $V_{IHhyst}$ | High Level Threshold       | non Schmitt, Input Rising  | 1.3                 | $0.5 \cdot V_{DD}$ | 2.0                 | V    |
| $V_{hyst}$   | Schmitt Trigger Hysteresis |                            | $0.23 \cdot V_{DD}$ |                    |                     | V    |
| $V_{OL}$     | Low Level Output           | Note 1                     |                     |                    | $0.15 \cdot V_{DD}$ | V    |
| $V_{OH}$     | High Level Output          | Note 1                     | $0.85 \cdot V_{DD}$ |                    |                     | V    |

Notes: 1. Source/Sink current under worst-case conditions.

## 1.0 PIN DESCRIPTION

### 1.1 MVO: Master Volume Override

This pin enables the user to bypass the Volume Control on all channels. When MVO is pulled High, the Master Volume Register is set to 00h, which corresponds to its Full Scale setting. The Master Volume Register Setting offsets the individual Channel Volume Settings, which default to 0dB.

### 1.2 SDI\_12 through 78: Serial Data In

Audio information enters the device here. Six format choices are available including I2S, left- or right-justified, LSB or MSB first, with word widths of 16, 18, 20 and 24 bits.

### 1.3 RESET

Driving this pin (low) turns off the outputs and returns all settings to their defaults.

### 1.4 I2C

The SA, SDA and SCL pins operate per the Philips I2C specification. See Section 2.

### 1.5 PLL: Phase Locked Loop

The phase locked loop section provides the System Timing Signals and CKOUT.

### 1.6 CKOUT: Clock Out

System synchronization and master clocks are provided by the CKOUT.

### 1.7 OUT1 through OUT8: PWM Outputs

The PWM outputs provide the input signal for the power devices.

### 1.8 EAPD: External Amplifier Power-Down

This signal can be used to control the power-down of DDX power devices.

### 1.9 SDO\_12 through 78: Serial Data Out

Audio information exits the device here. Six different format choices are available including I2S, left- or right-justified, LSB or MSB first, with word widths of 16, 18, 20 and 24 bits.

### 1.10 PWDN: Device Power-Down

This puts the STA308 into a low-power state via appropriate power-down sequence. Pulling PWDN low begins power-down sequence, and EAPD goes low ~30ms later.

## 2.0 I2C BUS SPECIFICATION

The STA308 supports the I2C protocol. This protocol defines any device that sends data on to the bus as a transmitter and any device that reads the data as a receiver. The device that controls the data transfer is known as the master and the other as the slave. The master always starts the transfer and provides the serial clock for synchronization. The STA308 is always a slave device in all of its communications.

## **2.1 COMMUNICATION PROTOCOL**

### **2.1.1 Data Transition or change**

Data changes on the SDA line must only occur when the SCL clock is low. SDA transition while the clock is high is used to identify a START or STOP condition.

### **2.1.2 Start Condition**

START is identified by a high to low transition of the data bus SDA signal while the clock signal SCL is stable in the high state. A START condition must precede any command for data transfer.

### **2.1.3 Stop Condition**

STOP is identified by low to high transition of the data bus SDA signal while the clock signal SCL is stable in the high state. A STOP condition terminates communication between STA308 and the bus master.

### **2.1.4 Data Input**

During the data input the STA308 samples the SDA signal on the rising edge of clock SCL. For correct device operation the SDA signal must be stable during the rising edge of the clock and the data can change only when the SCL line is low.

## **2.2 DEVICE ADDRESSING**

To start communication between the master and the STA308, the master must initiate with a start condition. Following this, the master sends onto the SDA line 8-bits (MSB first) corresponding to the device select address and read or write mode.

The 7 most significant bits are the device address identifiers, corresponding to the I2C bus definition. In the STA308 the I2C interface has two device addresses depending on the SA pin configuration, 0x30 or 0011000x when SA = 0, and 0x32 or 0011001x when SA = 1.

The 8th bit (LSB) identifies read or write operation RW, this bit is set to 1 in read mode and 0 for write mode. After a START condition the STA308 identifies on the bus the device address and if a match is found, it acknowledges the identification on SDA bus during the 9th bit time. The byte following the device identification byte is the internal space address.

## **2.3 WRITE OPERATION**

Following the START condition the master sends a device select code with the RW bit set to 0. The STA308 acknowledges this and the writes for the byte of internal address. After receiving the internal byte address the STA308 again responds with an acknowledgement.

### **2.3.1 Byte Write**

In the byte write mode the master sends one data byte, this is acknowledged by the STA308. The master then terminates the transfer by generating a STOP condition.

### **2.3.2 Multi-byte Write**

The multi-byte write modes can start from any internal address. The master generating a STOP condition terminates the transfer.



### Write Mode Sequence

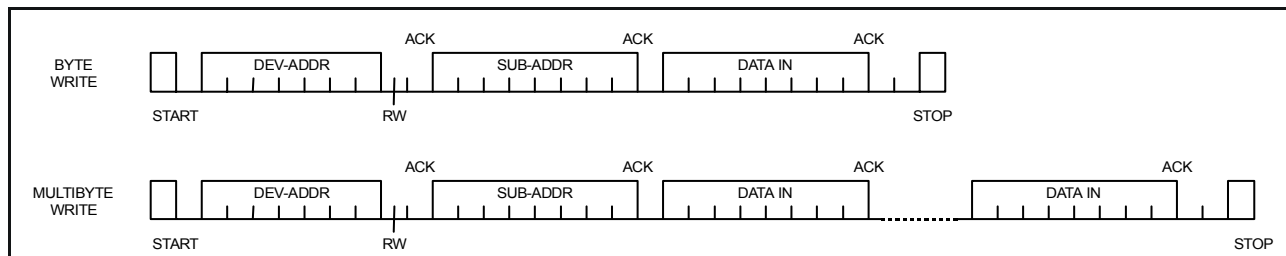

### Read Mode Sequence

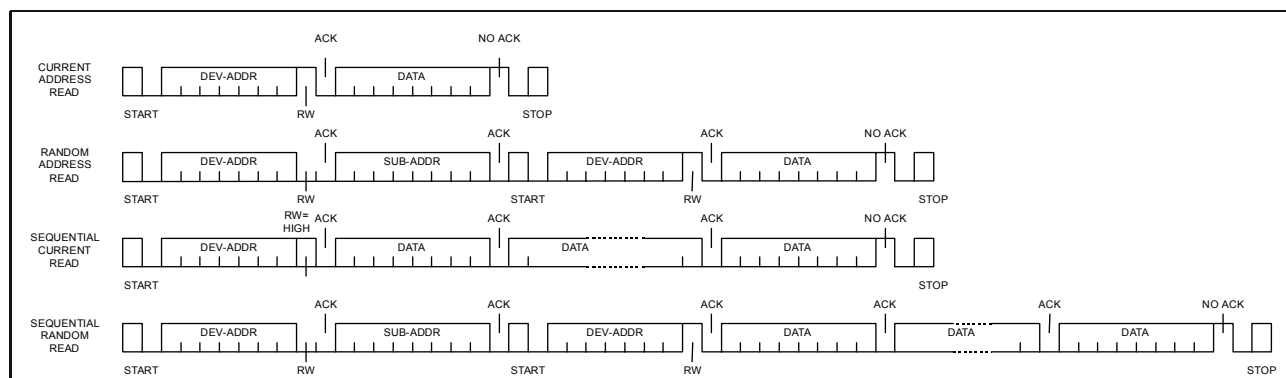

Table 1. Register summary

| Address | Name  | D7   | D6    | D5    | D4   | D3    | D2    | D1    | D0    |
|---------|-------|------|-------|-------|------|-------|-------|-------|-------|
| 00h     | ConfA | MPC  | HPE   | BME   | IR1  | IR0   | MCS2  | MCS1  | MCS0  |
| 01h     | ConfB | DRC  | ZCE   | SAIFB | SAI2 | SAI1  | SAI0  | ZDE   | DSPB  |
| 02h     | ConfC | HPB  | RES   | RES   | RES  | RES   | RES   | OM1   | OM0   |
| 03h     | ConfD | BQL  | PSL   | COS1  | COS0 | C78BO | C56BO | C34BO | C12BO |
| 04h     | ConfE | RES  | SAOFB | SAO2  | SAO1 | SAO0  | DEMP  | VOLEN | MIXE  |
| 05h     | ConfF | EAPD |       |       |      | AME   | COD   | I2SD  | PWMD  |
| 06h     | Mmute |      |       |       |      |       |       |       | MMute |
| 07h     | Mvol  | MV7  | MV6   | MV5   | MV4  | MV3   | MV2   | MV1   | MV0   |
| 08h     | Cmute | C8M  | C7M   | C6M   | C5M  | C4M   | C3M   | C2M   | C1M   |
| 09h     | C1Vol | C1V7 | C1V6  | C1V5  | C1V4 | C1V3  | C1V2  | C1V1  | C1V0  |
| 0Ah     | C2Vol | C2V7 | C2V6  | C2V5  | C2V4 | C2V3  | C2V2  | C2V1  | C2V0  |
| 0Bh     | C3Vol | C3V7 | C3V6  | C3V5  | C3V4 | C3V3  | C3V2  | C3V1  | C3V0  |
| 0Ch     | C4Vol | C4V7 | C4V6  | C4V5  | C4V4 | C4V3  | C4V2  | C4V1  | C4V0  |
| 0Dh     | C5Vol | C5V7 | C5V6  | C5V5  | C5V4 | C5V3  | C5V2  | C5V1  | C5V0  |
| 0Eh     | C6Vol | C6V7 | C6V6  | C6V5  | C6V4 | C6V3  | C6V2  | C6V1  | C6V0  |
| 0Fh     | C7Vol | C7V7 | C7V6  | C7V5  | C7V4 | C7V3  | C7V2  | C7V1  | C7V0  |

|     |         |       |       |       |       |       |       |       |       |
|-----|---------|-------|-------|-------|-------|-------|-------|-------|-------|
| 10h | C8Vol   | C8V7  | C8V6  | C8V5  | C8V4  | C8V3  | C8V2  | C8V1  | C8V0  |
| 11h | C12im   |       | C2IM2 | C2IM1 | C2IM0 |       | C1IM2 | C1IM1 | C1IM0 |
| 12h | C34im   |       | C4IM2 | C4IM1 | C4IM0 |       | C3IM2 | C3IM1 | C3IM0 |
| 13h | C56im   |       | C6IM2 | C6IM1 | C6IM0 |       | C5IM2 | C5IM1 | C5IM0 |
| 14h | C78im   |       | C8IM2 | C8IM1 | C8IM0 |       | C7IM2 | C7IM1 | C7IM0 |
| 15h | C1234ls | C4LS1 | C4LS0 | C3LS1 | C3LS0 | C2LS1 | C2LS0 | C1LS1 | C1LS0 |
| 16h | C5678ls | C8LS1 | C8LS0 | C7LS1 | C7LS0 | C6LS1 | C6LS0 | C5LS1 | C5LS0 |
| 17h | L1ar    | L1R3  | L1R2  | L1R1  | L1R0  | L1A3  | L1A2  | L1A1  | L1A0  |
| 18h | L1atrt  | L1AT3 | L1AT2 | L1AT1 | L1AT0 | L1RT3 | L1RT2 | L1RT1 | L1RT0 |
| 19h | L2ar    | L2R3  | L2R2  | L2R1  | L2R0  | L2A3  | L2A2  | L2A1  | L2A0  |
| 1Ah | L2atrt  | L2AT3 | L2AT2 | L2AT1 | L2AT0 | L2RT3 | L2RT2 | L2RT1 | L2RT0 |
| 1Bh | Tone    | TTC3  | TTC2  | TTC1  | TTC0  | BTC3  | BTC2  | BTC1  | BTC0  |
| 1Ch | Cfaddr  | CFA7  | CFA6  | CFA5  | CFA4  | CFA3  | CFA2  | CFA1  | CFA0  |
| 1Dh | B2cf1   | C1B23 | C1B22 | C1B21 | C1B20 | C1B19 | C1B18 | C1B17 | C1B16 |
| 1Eh | B2cf2   | C1B15 | C1B14 | C1B13 | C1B12 | C1B11 | C1B10 | C1B9  | C1B8  |
| 1Fh | B2cf3   | C1B7  | C1B6  | C1B5  | C1B4  | C1B3  | C1B2  | C1B1  | C1B0  |
| 20h | B0cf1   | C2B23 | C2B22 | C2B21 | C2B20 | C2B19 | C2B18 | C2B17 | C2B16 |
| 21h | B0cf2   | C2B15 | C2B14 | C2B13 | C2B12 | C2B11 | C2B10 | C2B9  | C2B8  |
| 22h | B0cf3   | C2B7  | C2B6  | C2B5  | C2B4  | C2B3  | C2B2  | C2B1  | C2B0  |
| 23h | A2cf1   | C3B23 | C3B22 | C3B21 | C3B20 | C3B19 | C3B18 | C3B17 | C3B16 |
| 24h | A2cf2   | C3B15 | C3B14 | C3B13 | C3B12 | C3B11 | C3B10 | C3B9  | C3B8  |
| 25h | A2cf3   | C3B7  | C3B6  | C3B5  | C3B4  | C3B3  | C3B2  | C3B1  | C3B0  |
| 26h | A1cf1   | C4B23 | C4B22 | C4B21 | C4B20 | C4B19 | C4B18 | C4B17 | C4B16 |
| 27h | A1cf2   | C4B15 | C4B14 | C4B13 | C4B12 | C4B11 | C4B10 | C4B9  | C4B8  |
| 28h | A1cf3   | C4B7  | C4B6  | C4B5  | C4B4  | C4B3  | C4B2  | C4B1  | C4B0  |
| 29h | B1cf1   | C5B23 | C5B22 | C5B21 | C5B20 | C5B19 | C5B18 | C5B17 | C5B16 |
| 2Ah | B1cf2   | C5B15 | C5B14 | C5B13 | C5B12 | C5B11 | C5B10 | C5B9  | C5B8  |
| 2Bh | B1cf3   | C5B7  | C5B6  | C5B5  | C5B4  | C5B3  | C5B2  | C5B1  | C5B0  |
| 2Ch | Cfud    |       |       |       |       |       |       | WA    | W1    |
| 2Dh | DC1     | RES   | RES   | RES   | RES   | RES   | RES   | RES   | RES   |
| 2Eh | DC2     | RES   | RES   | RES   | RES   | RES   | RES   | RES   | RES   |
| 2Fh | BIST1   | RES   | RES   | RES   | RES   | RES   | RES   | RES   | RES   |
| 30h | BIST2   |       |       |       | RES   | RES   | RES   | RES   | RES   |

### 3.0 CONFIGURATION REGISTER A (ADDRESS 00H)

| BIT  | D7  | D6  | D5  | D4  | D3  | D2   | D1   | D0   |
|------|-----|-----|-----|-----|-----|------|------|------|
| NAME | MPC | HPE | BME | IR1 | IR0 | MCS2 | MCS1 | MCS0 |
| RST  | 1   | 0   | 0   | 0   | 0   | 0    | 1    | 1    |

#### 3.0.1 Master Clock Select

| BIT | R/W | RST | NAME | DESCRIPTION  |
|-----|-----|-----|------|--|
| 0   | R/W | 1   | MCS0 | Master Clock Select : Selects the ratio between the input I <sup>2</sup> S sample frequency and the input clock. |
| 1   | R/W | 1   | MCS1 |  |
| 2   | R/W | 0   | MCS2 |  |

The STA308 will support sample rates of 32kHz, 44.1kHz, 48kHz, 88.2kHz, 96kHz, 176.4kHz, and 192kHz. Therefore the internal clock will be:

- 65.536Mhz for 32kHz
- 90.3168Mhz for 44.1kHz, 88.2kHz, and 176.4kHz
- 98.304Mhz for 48kHz, 96kHz, and 192kHz

The external clock frequency provided to the XTI pin must be a multiple of the input sample frequency(fs). The relationship between the input clock and the input sample rate is determined by both the MCSx and the IRx (Input Rate) register bits. The MCSx bits determine the PLL factor generating the internal clock and the IRx bits determine the oversampling ratio used internally.

| Input Sample Rate<br><i>f<sub>s</sub></i> (kHz) | IR | MCS(2..0) |       |       |       |       |
|---|----|-----------|-------|-------|-------|-------|
|   |    | 1xx       | 011   | 010   | 001   | 000   |
| 32, 44.1, 48                                    | 00 | 128fs     | 256fs | 384fs | 512fs | 768fs |
| 88.2, 96  | 01 | 64fs      | 128fs | 192fs | 256fs | 384fs |
| 176.4, 192                                      | 10 | 64fs      | 128fs | 192fs | 256fs | 384fs |

#### 3.0.2 Interpolation Ratio Select

| BIT | R/W | RST | NAME | DESCRIPTION  |
|-----|-----|-----|------|--|
| 3   | R/W | 0   | IR0  | Interpolation Ratio Select : Selects internal interpolation ratio based on input I <sup>2</sup> S sample frequency |
| 4   | R/W | 0   | IR1  |  |

The STA308 has variable interpolation (oversampling) settings such that internal processing and DDX output rates remain consistent. The first processing block interpolates by either 4 times, 2 times, or 1 time (pass-through). The IR bits determine the oversampling ratio of this interpolation.

**Table 2. IR bit settings as a function of Input Sample Rate.**

| Input Sample Rate <i>F<sub>s</sub></i> | IR(1,0) | 1 <sup>st</sup> Stage Interpolation Ratio |
|--|---------|---|
| 32kHz                                  | 00      | 4 times oversampling                      |
| 44.1kHz                                | 00      | 4 times oversampling                      |
| 48kHz                                  | 00      | 4 times oversampling                      |
| 88.2kHz                                | 01      | 2 times oversampling                      |
| 96kHz                                  | 01      | 2 times oversampling                      |
| 176.4kHz                               | 10      | Pass-Through                              |
| 192kHz                                 | 10      | Pass-Through                              |

**3.0.3 Bass Management Enable**

| BIT | R/W | RST | NAME | DESCRIPTION   |
|-----|-----|-----|------|---|
| 5   | R/W | 0   | BME  | Bass Management Enable : 0 – No Bass Management<br>1 – Bass Management operation on channel 6, scale and add inputs |

Channel 6 of the STA308 features a bass management mode that enables redirection of information in all other channels to this channel and which can then be filtered appropriately using the EQ(Biquad) section. Setting the BME bit selects the output of the scale and mix block for channel 6 instead of the output of the channel mapping block. The settings for the scale and mix block are provided by the CxBMS registers

**3.0.4 DDX Headphone Output Enable**

| BIT | R/W | RST | NAME | DESCRIPTION   |
|-----|-----|-----|------|---|
| 6   | R/W | 0   | HPE  | DDX Headphone Enable :<br>0 – Channels 7,8 normal DDX operation.<br>1 – Channels 7,8 DDX Headphone operation. |

Channels 7 and 8 of the STA308 have the option to be processed for headphones. The headphone output can then be driven using an appropriate output device. This signal is a fully differential 3-wire drive called DDX Headphone

**3.0.5 Max Power Correction**

| BIT | R/W | RST | NAME | DESCRIPTION   |
|-----|-----|-----|------|---|
| 7   | R/W | 1   | MPC  | Max Power Correction : Setting of 1 enables DDX correction for THD reduction near maximum power output. |

Setting the MPC bit turns on special processing that corrects the DDX power device at high power. This mode should lower the THD+N of a full DDX system at maximum power output and slightly below. This mode will only be operational in OM= 00 or 10.

**3.1 Configuration Register B (address 01h)**

| BIT  | D7  | D6  | D5    | D4   | D3   | D2   | D1  | D0   |
|------|-----|-----|-------|------|------|------|-----|------|
| NAME | DRC | ZCE | SAIFB | SAI2 | SAI1 | SAI0 | ZDE | DSPB |
| RST  | 0   | 1   | 0     | 0    | 0    | 0    | 1   | 0    |

**3.1.1 DSP Bypass**

| BIT | R/W | RST | NAME | DESCRIPTION   |
|-----|-----|-----|------|---|
| 0   | R/W | 0   | DSPB | DSP Bypass Bit : 0 – Normal Operation<br>1 – Bypass of Biquad and Bass/Treble Functionality |

Setting the DSPB bit bypasses the biquad and bass/treble functionality of the STA308.

**3.1.2 Zero-Detect Mute Enable**

| BIT | R/W | RST | NAME | DESCRIPTION   |
|-----|-----|-----|------|---|
| 1   | R/W | 1   | ZDE  | Zero-Detect Mute Enable : Setting of 1 enables the automatic zero-detect mute |

Setting the ZDE bit enables the zero-detect automatic mute.

The zero-detect circuit looks at the input data to each processing channel after the channel mapping block. If any channel receives 2048 consecutive zero value samples (regardless of fs) then that individual channel is muted if this function is enabled.

**Serial Audio Input Interface Format**

| BIT | R/W | RST | NAME | DESCRIPTION  |
|-----|-----|-----|------|--|
| 2   | R/W | 0   | SAI0 | Serial Audio Input Interface Format : Determines the interface format of the input serial digital audio interface. |
| 3   | R/W | 0   | SAI1 |  |
| 4   | R/W | 0   | SAI2 |  |

The STA308 features a configurable digital serial audio interface. The settings of the SAIx bits determine how the input to this interface is interpreted. Six formats are accepted.

**Table 3. Interface format as a function of SAI bits.**

| SAI(2..0) | Interface Format            |
|-----------|-----------------------------|
| 000       | I <sup>2</sup> S            |
| 001       | Left-Justified Data         |
| 010       | Right-Justified 16-bit Data |
| 011       | Right-Justified 18-bit Data |
| 100       | Right-Justified 20-bit Data |
| 101       | Right-Justified 24-bit Data |

**Figure 2. Serial Audio Signals**

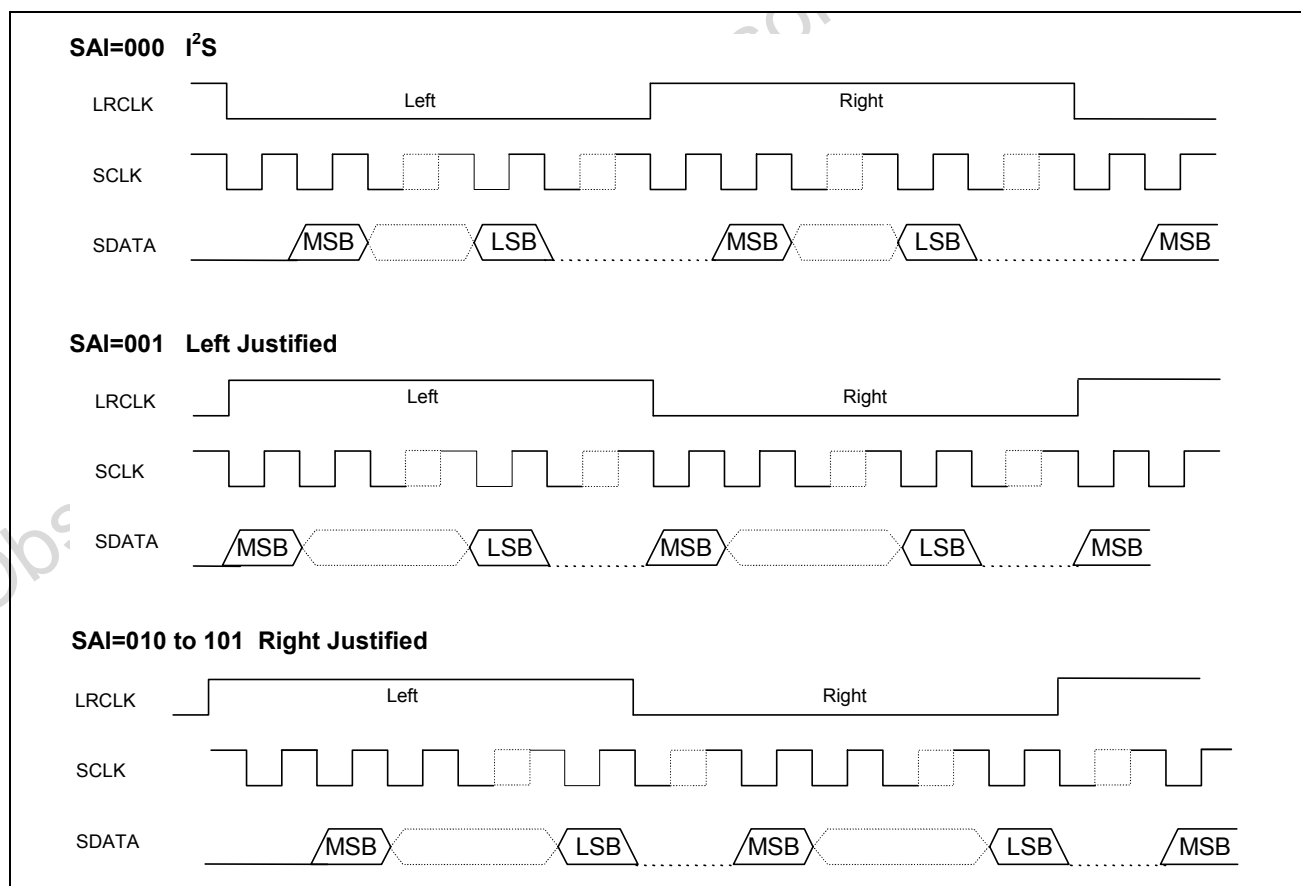

**3.1.3 Serial Audio Input Interface First Bit**

| BIT | R/W | RST | NAME  | DESCRIPTION   |
|-----|-----|-----|-------|---|
| 5   | R/W | 0   | SAIFB | Determines MSB or LSB first for all SAI formats<br>0 – MSB First, 1 – LSB First |

**3.1.4 Zero-Crossing Volume Enable**

| BIT | R/W | RST | NAME | DESCRIPTION  |
|-----|-----|-----|------|--|
| 6   | R/W | 1   | ZCE  | Zero-Crossing Volume Enable :<br>1 – Volume adjustments will only occur at digital zero-crossings<br>0 – Volume adjustments will occur immediately |

The ZCE bit enables zero-crossing volume adjustments. When volume is adjusted on digital zero-crossings, "zipper noise" is eliminated

**3.1.5 Dynamic Range Compression/Anti-Clipping Bit**

| BIT | R/W | RST | NAME | DESCRIPTION  |
|-----|-----|-----|------|--|
| 7   | R/W | 0   | DRC  | Dynamic Range Compression/Anti-Clipping<br>0 – Limiters act in Anti-Clipping Mode<br>1- Limiters act in Dynamic Range Compression Mode |

Both limiters can be used in one of two ways, anti-clipping or dynamic range compression. When used in anti-clipping mode the limiter threshold values are constant and dependent on the gain/attenuation settings applied to the input signal. In dynamic range compression mode the limiter threshold values vary with the volume settings allowing for limiting to occur independently of the gain/attenuation but dependent on the input signal

**3.2 Configuration Register C (address 02h)**

| BIT  | D7  | D6  | D5  | D4  | D3  | D2  | D1  | D0  |
|------|-----|-----|-----|-----|-----|-----|-----|-----|
| NAME | HPB | RES | RES | RES | RES | RES | OM1 | OM0 |
| RST  | 0   | 1   | 1   | 1   | 1   | 1   | 0   | 0   |

**3.2.1 DDX Power Output Mode**

| BIT | R/W | RST | NAME | DESCRIPTION  |
|-----|-----|-----|------|--|
| 0   | R/W | 0   | OM0  | DDX Power Output Mode : Selects configuration of DDX output. |
| 1   | R/W | 0   | OM1  |  |

The DDX Power Output Mode selects how the DDX output timing is configured. Different power devices use different output modes. The DDX recommended use is OM = 00. The variable mode uses the OMVx bits for adjustment

| OM(1,0) | Output Stage - Mode                             |
|---------|---|
| 00      | Fixed Compensation                              |
| 01      | RESERVED  |
| 10      | Full Power Moderecomanded for STA500 and STA505 |
| 11      | RESERVED  |

### 3.2.2 High-Pass Filter Bypass

| BIT | R/W | RST | NAME | DESCRIPTION  |
|-----|-----|-----|------|--|
| 7   | R/W | 0   | HPB  | High-Pass Filter Bypass Bit. Setting of one bypasses internal AC coupling digital high-pass filter |

The STA308 features an internal digital high-pass filter for the purpose of AC coupling. The purpose of this filter is to prevent DC signals from passing through a DDX amplifier. DC signals can cause speaker damage

### 3.3 Configuration Register D (address 03h)

| BIT  | D7  | D6  | D5   | D4   | D3    | D2    | D1    | D0    |
|------|-----|-----|------|------|-------|-------|-------|-------|
| NAME | BQL | PSL | COS1 | COS0 | C78BO | C56BO | C34BO | C12BO |
| RST  | 0   | 0   | 1    | 0    | 0     | 0     | 0     | 0     |

#### 3.3.1 Binary Output Enable Registers

| BIT | R/W | RST | NAME  | DESCRIPTION  |
|-----|-----|-----|-------|--|
| 0   | R/W | 0   | C12BO | Channels 1&2, 3&4, 5&6, 7&8 Binary Output Mode Enable Bits. A setting of 0 indicates ordinary DDX tri-state output. A setting of 1 indicates binary output mode. |
| 1   | R/W | 0   | C34BO |  |
| 2   | R/W | 0   | C56BO |  |
| 3   | R/W | 0   | C78BO |  |

Each two-channel pair of outputs can be set to output a binary PWM stream. In this mode, output A of a channel will be considered the positive output and output B is negative inverse. For example, setting C34BO = 1 sets channels 3&4 to Binary Output (PWM) Mode.

#### 3.3.2 Clock Output Select

| BIT | R/W | RST | NAME | DESCRIPTION         |
|-----|-----|-----|------|---------------------|
| 4   | R/W | 0   | COS0 | Clock Output Select |
| 5   | R/W | 1   | COS1 | Clock Output Select |

The Clock Output Select register selects the frequency of the clock output pin relative to the PLL clock output. The PLL clock runs at 2048fs for 32, 44.1, and 48kHz, at 1024fs for 88.2kHz and 96 kHz, and at 512fs for 176.4kHz and 192kHz.

| COS(1,0) | CKOUT Frequency |
|----------|-----------------|
| 01       | PLL Output/4    |
| 10       | PLL Output/8    |
| 11       | PLL Output/16   |

#### 3.3.3 Post-Scale Link

| BIT | R/W | RST | NAME | DESCRIPTION  |
|-----|-----|-----|------|--|
| 6   | R/W | 0   | PSL  | Post-Scale Link :0 – Each Channel uses individual Post-Scale value<br>1 - Each Channel uses Channel 1 Post-Scale value |

For multi-channel applications, the post-scale values can be linked to the value of channel 1 for ease of use and update the values faster.

**3.3.4 Biquad Coefficient Link**

| BIT | R/W | RST | NAME | DESCRIPTION  |
|-----|-----|-----|------|--|
| 7   | R/W | 0   | BQL  | Biquad Link :<br>0 – Each Channel uses coefficient values<br>1- Each Channel uses Channel 1 coefficient values |

For ease of use, all channels can use the biquad coefficients loaded into the Channel 1 Coefficient RAM space by setting the BQL bit to 1. Then any EQ updates would only have to be performed once.

**3.4 Configuration Register E (address 04h)**

| BIT  | D7  | D6    | D5   | D4   | D3   | D2   | D1    | D0   |
|------|-----|-------|------|------|------|------|-------|------|
| NAME | RES | SAOFB | SAO2 | SAO1 | SAO0 | DEMP | VOLEN | MIXE |
| RST  | 0   | 0     | 0    | 0    | 0    | 0    | 1     | 0    |

| BIT | R/W | RST | NAME | DESCRIPTION   |
|-----|-----|-----|------|---|
| 0   | R/W | 0   | MIXE | Mix Enable: 0 – Normal Operation<br>1 - Adjacent Channel Mix Mode |

The scale and mix functionality can be used to mix adjacent channels instead of for bass management. By setting this bit(BME must be set to 0) odd channels will be mixed with their adjacent even channel and output in the place of the even channel. The odd channel will pass-through unscaled. The values used for this function are the same as for bass management. Since this function occurs post channel mapping a large number of possibilities are present for two channel mixing. Up to four mixed channels can be obtained.

| BIT | R/W | RST | NAME  | DESCRIPTION   |
|-----|-----|-----|-------|---|
| 1   | R/W | 1   | VOLEN | Volume Enable: 0 – Volume Operation Bypassed<br>1 - Volume Operation Normal |

When VOLEN set to 1, volume operation is normal. When set to 0, volume operation is bypassed and the volume stages are all set to pass-through. This also eliminates the digital volume offset of ~-0.6dB that is used to map full-scale digital input to full DDX modulation output.

| BIT | R/W | RST | NAME | DESCRIPTION                                   |
|-----|-----|-----|------|---|
| 2   | R/W | 0   | DEMP | Deemphasis : 0 – No Deemphasis, 1- Deemphasis |

By setting this bit to one deemphasis will be implemented on all channels. When this is used it takes the place of biquad #1 in each channel and any coefficients using biquad #1 will be ignored. DSPB(DSP Bypass) bit must be set to 0 for Deemphasis to function.

| BIT | R/W | RST | NAME | DESCRIPTION  |
|-----|-----|-----|------|--|
| 3   | R/W | 0   | SAO0 | Serial Audio Output Interface Format : Determines the interface format of the output serial digital audio interface. |
| 4   | R/W | 0   | SAO1 |  |
| 5   | R/W | 0   | SAO2 |  |

The STA308 features a configurable digital serial audio interface. The settings of the SAIx bits determine how the output to this interface is interpreted. Six formats are accepted.



**Table 4. Interface format as a function of SAO bits.**

| SAO(2..0) | Interface Format            |
|-----------|-----------------------------|
| 000       | I <sup>2</sup> S            |
| 001       | Left-Justified Data         |
| 010       | Right-Justified 16-bit Data |
| 011       | Right-Justified 18-bit Data |
| 100       | Right-Justified 20-bit Data |
| 101       | Right-Justified 24-bit Data |

| BIT | R/W | RST | NAME  | DESCRIPTION  |
|-----|-----|-----|-------|--|
| 6   | R/W | 0   | SAOFB | Determines MSB or LSB first for all SAO formats;<br>0 – MSB First<br>1 – LSB First |

**3.5 Configuration Register F (address 05h)**

| BIT  | D7   | D6 | D5 | D4 | D3  | D2  | D1  | D0   |
|------|------|----|----|----|-----|-----|-----|------|
| NAME | EAPD |    |    |    | AME | COD | SID | PWMD |
| RST  | 0    |    |    |    | 0   | 0   | 0   | 0    |

| BIT | R/W | RST | NAME | DESCRIPTION   |
|-----|-----|-----|------|---|
| 0   | R/W | 0   | PWMD | PWM Output Disable: 0 – PWM Output Normal<br>1- No PWM Output   |
| 1   | R/W | 0   | SID  | Serial Interface(I <sup>2</sup> S Out) Disable: 0 – I <sup>2</sup> S Output Normal<br>1- No I <sup>2</sup> S Output |
| 2   | R/W | 0   | COD  | Clock Output Disable: 0 – Clock Output Normal<br>1- No Clock Output   |
| 3   | R/W | 0   | AME  | AM Mode Enable : 0 – Normal DDX operation.<br>1 – AM reduction mode DDX operation.                                  |

The STA308 features a DDX processing mode that minimizes the amount of noise generated in frequency range of AM radio. This mode is intended to be used when DDX is operating in a device with an AM tuner active. The SNR of the DDX processing is reduced to ~83dB in this mode, which is still greater than the SNR of AM radio.

| BIT | R/W | RST | NAME | DESCRIPTION  |
|-----|-----|-----|------|--|
| 7   | R/W | 0   | EAPD | External Amplifier Power Down:<br>0 – External Power Stage Power Down Active<br>1 - Normal Operation |

This output bit, on pin 51 of the device, is used to mute the DDX Power Devices for Power-Down.

**3.6 Master Mute Register (address 06h)**

| BIT  | D7 | D6 | D5 | D4 | D3 | D2 | D1 | D0    |
|------|----|----|----|----|----|----|----|-------|
| NAME |    |    |    |    |    |    |    | MMUTE |
| RST  |    |    |    |    |    |    |    | 0     |

**3.7 Master Volume Register (address 07h)**

| BIT  | D7  | D6  | D5  | D4  | D3  | D2  | D1  | D0  |
|------|-----|-----|-----|-----|-----|-----|-----|-----|
| NAME | MV7 | MV6 | MV5 | MV4 | MV3 | MV2 | MV1 | MV0 |
| RST  | 1   | 1   | 1   | 1   | 1   | 1   | 1   | 1   |

**3.8 Channels 1,2,3,4,5,6,7,8 Mute (address 08h)**

| BIT  | D7  | D6  | D5  | D4  | D3  | D2  | D1  | D0  |
|------|-----|-----|-----|-----|-----|-----|-----|-----|
| NAME | C8M | C7M | C6M | C5M | C4M | C3M | C2M | C1M |
| RST  | 0   | 0   | 0   | 0   | 0   | 0   | 0   | 0   |

**3.9 Channel 1 Volume (address 09h)**

| BIT  | D7   | D6   | D5   | D4   | D3   | D2   | D1   | D0   |
|------|------|------|------|------|------|------|------|------|
| NAME | C1V7 | C1V6 | C1V5 | C1V4 | C1V3 | C1V2 | C1V1 | C1V0 |
| RST  | 0    | 0    | 1    | 1    | 0    | 0    | 0    | 0    |

**3.10 Channel 2 Volume (address 0Ah)**

| BIT  | D7   | D6   | D5   | D4   | D3   | D2   | D1   | D0   |
|------|------|------|------|------|------|------|------|------|
| NAME | C2V7 | C2V6 | C2V5 | C2V4 | C2V3 | C2V2 | C2V1 | C2V0 |
| RST  | 0    | 0    | 1    | 1    | 0    | 0    | 0    | 0    |

**3.11 Channel 3 Volume (address 0Bh)**

| BIT  | D7   | D6   | D5   | D4   | D3   | D2   | D1   | D0   |
|------|------|------|------|------|------|------|------|------|
| NAME | C3V7 | C3V6 | C3V5 | C3V4 | C3V3 | C3V2 | C3V1 | C3V0 |
| RST  | 0    | 0    | 1    | 1    | 0    | 0    | 0    | 0    |

**3.12 Channel 4 Volume (address 0Ch)**

| BIT  | D7   | D6   | D5   | D4   | D3   | D2   | D1   | D0   |
|------|------|------|------|------|------|------|------|------|
| NAME | C4V7 | C4V6 | C4V5 | C4V4 | C4V3 | C4V2 | C4V1 | C4V0 |
| RST  | 0    | 0    | 1    | 1    | 0    | 0    | 0    | 0    |

**3.13 Channel 5 Volume (address 0Dh)**

| BIT  | D7   | D6   | D5   | D4   | D3   | D2   | D1   | D0   |
|------|------|------|------|------|------|------|------|------|
| NAME | C5V7 | C5V6 | C5V5 | C5V4 | C5V3 | C5V2 | C5V1 | C5V0 |
| RST  | 0    | 0    | 1    | 1    | 0    | 0    | 0    | 0    |

### 3.14 Channel 6 Volume (address 0Eh)

| BIT  | D7   | D6   | D5   | D4   | D3   | D2   | D1   | D0   |
|------|------|------|------|------|------|------|------|------|
| NAME | C6V7 | C6V6 | C6V5 | C6V4 | C6V3 | C6V2 | C6V1 | C6V0 |
| RST  | 0    | 0    | 1    | 1    | 0    | 0    | 0    | 0    |

### 3.15 Channel 7 Volume (address 0Fh)

| BIT  | D7   | D6   | D5   | D4   | D3   | D2   | D1   | D0   |
|------|------|------|------|------|------|------|------|------|
| NAME | C7V7 | C7V6 | C7V5 | C7V4 | C7V3 | C7V2 | C7V1 | C7V0 |
| RST  | 0    | 0    | 1    | 1    | 0    | 0    | 0    | 0    |

### 3.16 Channel 8 Volume (address 10h)

| BIT  | D7   | D6   | D5   | D4   | D3   | D2   | D1   | D0   |
|------|------|------|------|------|------|------|------|------|
| NAME | C8V7 | C8V6 | C8V5 | C8V4 | C8V3 | C8V2 | C8V1 | C8V0 |
| RST  | 0    | 0    | 1    | 1    | 0    | 0    | 0    | 0    |

The Volume structure of the STA308 consists of individual volume registers for each channel and a master volume register that provides an offset to each channels volume setting. The individual channel volumes are adjustable in 0.5dB steps from +24dB to -103dB. As an example if C5V = 0Bh or +18.5dB and MV = 21h or -16.5dB, then the total gain for channel 5 = +2dB. The Master Mute when set to 1 will mute all channels at once, whereas the individual channel mutes(CxM) will mute only that channel. Both the Master Mute and the Channel Mutes provide a "soft mute" with the volume ramping down to mute in 8192 samples from the maximum volume setting at the internal processing rate(~192kHz). A "hard mute" can be obtained by commanding a value of all 1's(255) to any channel volume register or the master volume register. When volume offsets are provided via the master volume register any channel that whose total volume is less than -103dB will be muted. All changes in volume take place at zero-crossings when ZCE = 1(configuration register B) on a per channel basis as this creates the smoothest possible volume transitions. When ZCE=0, volume updates will occur immediately.

**Table 5. Master Volume Offset as a function of MV(7..0).**

| MV(7..0)      | Volume Offset from Channel Value |
|---------------|----------------------------------|
| 00000000(00h) | 0dB                              |
| 00000001(01h) | -0.5dB                           |
| 00000010(02h) | -1dB                             |
| ...           | ...                              |
| 01001100(4Ch) | -38dB                            |
| ...           | ...                              |
| 11111110(FEh) | -127dB                           |
| 11111111(FFh) | Hard Master Mute                 |

**Channel Volume as a function of CxV(7..0)**

| CxV(7..0)     | Volume            |
|---------------|-------------------|
| 00000000(00h) | +24dB             |
| 00000001(01h) | +23.5dB           |
| 00000010(02h) | +23dB             |
| ...           | ...               |
| 00101111(2Fh) | +0.5dB            |
| 00110000(30h) | 0dB               |
| 00110001(31h) | -0.5dB            |
| ...           | ...               |
| 11111110(FEh) | -103dB            |
| 11111111(FFh) | Hard Channel Mute |

**3.17 Channel Input Mapping Channels 1 & 2 (address 11h)**

| BIT  | D7 | D6    | D5    | D4    | D3 | D2    | D1    | D0    |
|------|----|-------|-------|-------|----|-------|-------|-------|
| NAME |    | C2IM2 | C2IM1 | C2IM0 |    | C1IM2 | C1IM1 | C1IM0 |
| RST  |    | 0     | 0     | 1     |    | 0     | 0     | 0     |

**3.18 Channel Input Mapping Channels 3 & 4 (address 12h)**

| BIT  | D7 | D6    | D5    | D4    | D3 | D2    | D1    | D0    |
|------|----|-------|-------|-------|----|-------|-------|-------|
| NAME |    | C4IM2 | C4IM1 | C4IM0 |    | C3IM2 | C3IM1 | C3IM0 |
| RST  |    | 0     | 1     | 1     |    | 0     | 1     | 0     |

**3.19 Channel Input Mapping Channels 5 & 6 (address 13h)**

| BIT  | D7 | D6    | D5    | D4    | D3 | D2    | D1    | D0    |
|------|----|-------|-------|-------|----|-------|-------|-------|
| NAME |    | C6IM2 | C6IM1 | C6IM0 |    | C5IM2 | C5IM1 | C5IM0 |
| RST  |    | 1     | 0     | 1     |    | 1     | 0     | 0     |

**3.20 Channel Input Mapping Channels 7 & 8 (address 14h)**

| BIT  | D7 | D6    | D5    | D4    | D3 | D2    | D1    | D0    |
|------|----|-------|-------|-------|----|-------|-------|-------|
| NAME |    | C8IM2 | C8IM1 | C8IM0 |    | C7IM2 | C7IM1 | C7IM0 |
| RST  |    | 1     | 1     | 1     |    | 1     | 1     | 0     |

Each channel received via I2S can be mapped to any internal processing channel via the Channel Input Mapping registers. This allows for flexibility in processing, simplifies output stage designs, and enables the ability to perform crossovers. The default settings of these registers map each I2S input channel to its corresponding processing channel.

For example, to map input 2 to Channel 5, set Address 11h, bits D6, D5 and D4 to 100. Now, inputs 2 and 5 go to Channel 5.

Table 6. Channel Mapping as a function of CxIM bits

| CxIM(2..0) | I <sup>2</sup> S Input Mapped to: |
|------------|-----------------------------------|
| 000        | Channel 1                         |
| 001        | Channel 2                         |
| 010        | Channel 3                         |
| 011        | Channel 4                         |
| 100        | Channel 5                         |
| 101        | Channel 6                         |
| 110        | Channel 7                         |
| 111        | Channel 8                         |

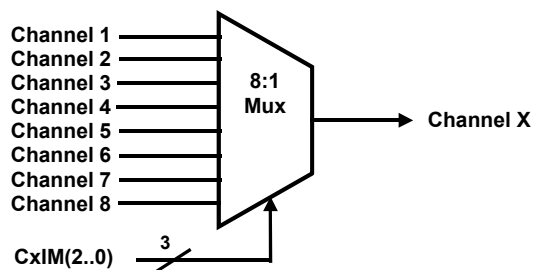

STA308 Output Phasing

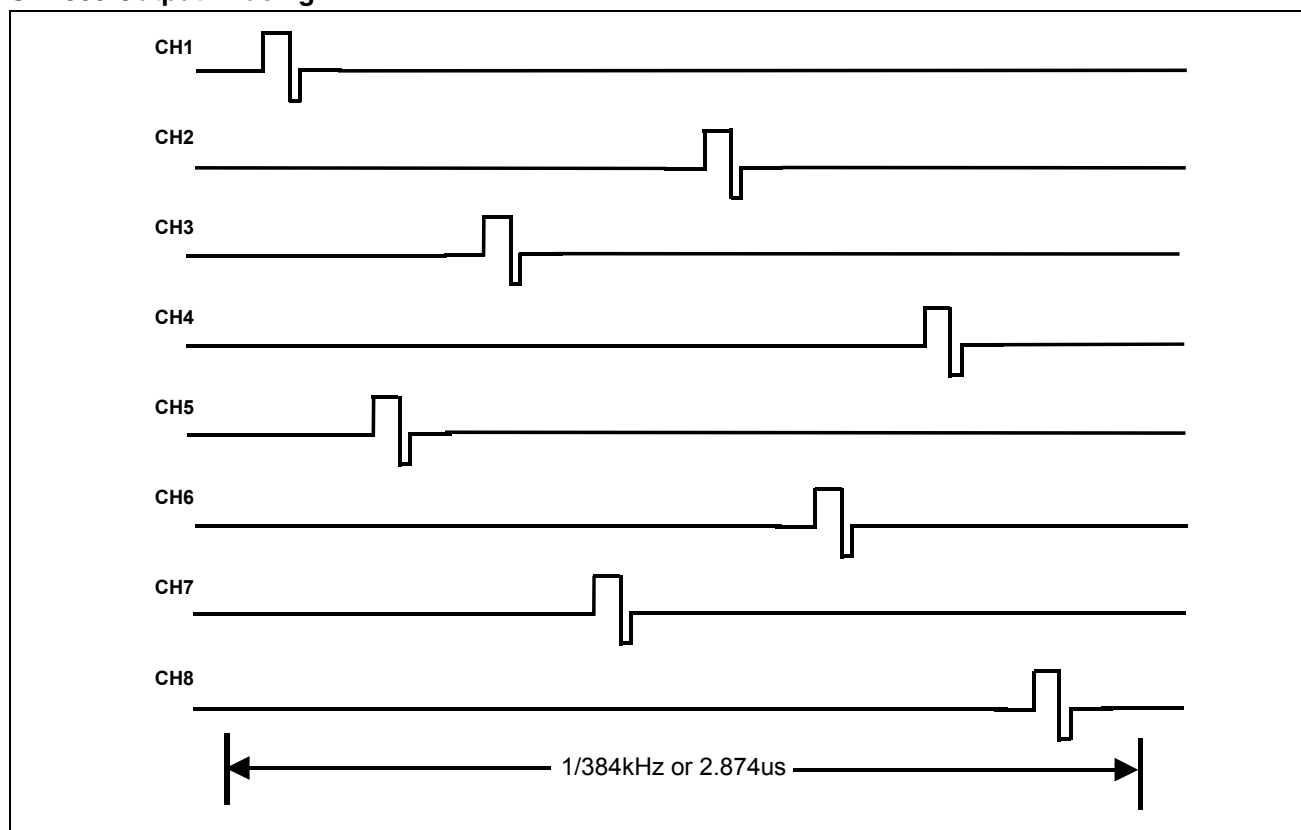

3.21 Channel Limiter Select Channels 1,2,3,4 (address 15h)

| BIT  | D7    | D6    | D5    | D4    | D3    | D2    | D1    | D0    |
|------|-------|-------|-------|-------|-------|-------|-------|-------|
| NAME | C4LS1 | C4LS0 | C3LS1 | C3LS0 | C2LS1 | C2LS0 | C1LS1 | C1LS0 |
| RST  | 0     | 0     | 0     | 0     | 0     | 0     | 0     | 0     |

3.22 Channel Limiter Select Channels 5,6,7,8 (address 16h)

| BIT  | D7    | D6    | D5    | D4    | D3    | D2    | D1    | D0    |
|------|-------|-------|-------|-------|-------|-------|-------|-------|
| NAME | C8LS1 | C8LS0 | C7LS1 | C7LS0 | C6LS1 | C6LS0 | C5LS1 | C5LS0 |
| RST  | 0     | 0     | 0     | 0     | 0     | 0     | 0     | 0     |

**3.23 Limiter 1 Attack/Release Rate (address 17h)**

| BIT  | D7   | D6   | D5   | D4   | D3   | D2   | D1   | D0   |
|------|------|------|------|------|------|------|------|------|
| NAME | L1R3 | L1R2 | L1R1 | L1R0 | L1A3 | L1A2 | L1A1 | L1A0 |
| RST  | 1    | 0    | 1    | 0    | 0    | 1    | 1    | 0    |

**3.24 Limiter 1 Attack/Release Threshold (address 18h)**

| BIT  | D7    | D6    | D5    | D4    | D3    | D2    | D1    | D0    |
|------|-------|-------|-------|-------|-------|-------|-------|-------|
| NAME | L1AT3 | L1AT2 | L1AT1 | L1AT0 | L1RT3 | L1RT2 | L1RT1 | L1RT0 |
| RST  | 0     | 1     | 1     | 0     | 0     | 1     | 1     | 1     |

**3.25 Limiter 2 Attack/Release Rate (address 19h)**

| BIT  | D7   | D6   | D5   | D4   | D3   | D2   | D1   | D0   |
|------|------|------|------|------|------|------|------|------|
| NAME | L2R3 | L2R2 | L2R1 | L2R0 | L2A3 | L2A2 | L2A1 | L2A0 |
| RST  | 1    | 0    | 1    | 0    | 0    | 1    | 1    | 0    |

**3.26 Limiter 2 Attack/Release Threshold (address 1Ah)**

| BIT  | D7    | D6    | D5    | D4    | D3    | D2    | D1    | D0    |
|------|-------|-------|-------|-------|-------|-------|-------|-------|
| NAME | L2AT3 | L2AT2 | L2AT1 | L2AT0 | L2RT3 | L2RT2 | L2RT1 | L2RT0 |
| RST  | 0     | 1     | 1     | 0     | 0     | 1     | 1     | 1     |

**Basic Limiter and Volume Flow Diagram.**

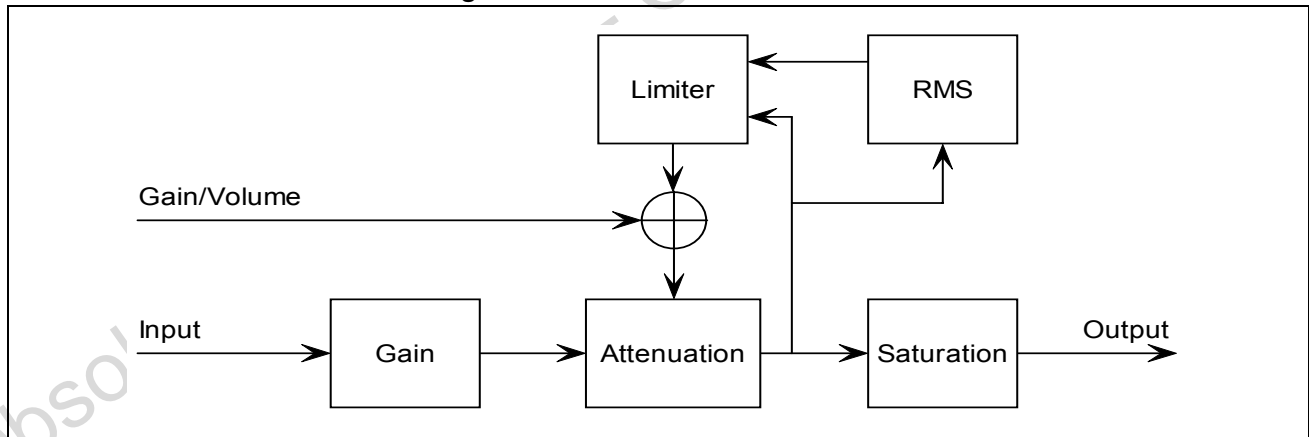

A limiter is basically a variable gain device, where the amount of gain applied depends on the input signal level. As the name implies, compression limits the dynamic range of the signal.

The STA308 includes 2 independent limiter blocks.

The purpose of the limiters is to automatically reduce the dynamic range of the input signal to prevent the outputs from clipping in anti-clipping mode or to actively reduce the dynamic range for a better listening environment such as a night-time listening mode which is often needed for DVDs. The two modes are selected via the DRC bit in Configuration Register B; address 0x02, bit 7.

Each channel can be mapped to either limiter or not mapped. Non-mapped channels will clip when 0dBFS is exceeded. Each limiter will look at the present value of each channel that is mapped to it, select the maximum

absolute value of all these channels, perform the limiting algorithm on that value, and then, if needed, adjust the gain of the mapped channels in unison.

The limiter attack thresholds are determined by the LxAT registers. It is recommended in anti-clipping mode to set this to 0dBFS, which corresponds to the maximum unclipped output power of a DDX amplifier. Since gain can be added digitally within the STA308 it is possible to exceed 0dBFS or any other LxAT setting. When this occurs, the limiter, when active, will automatically start reducing the gain. The rate at which the gain is reduced when the attack threshold is exceeded is dependent upon the attack rate register setting for that limiter. The gain reduction occurs on a peak-detect algorithm.

The release of limiter (uncompression), when the gain is again increased, is dependent on a RMS-detect algorithm. The output of the volume/limiter block is passed through a RMS filter. The output of this filter is compared to the release threshold, determined by the Release Threshold register. When the RMS filter output falls below the release threshold, the gain is again increased (uncompressed) at a rate dependent upon the Release Rate register. The gain can never be increased past its set value and therefore the release will only occur if the limiter has already reduced the gain.

The release threshold value can be used to set what is effectively a minimum dynamic range, this is helpful as over-limiting can reduce the dynamic range to virtually zero and cause program material to sound "lifeless". In AC mode the attack and release thresholds are set relative to full-scale. In DRC mode the attack threshold is set relative to the maximum volume setting of the channels mapped to that limiter and the release threshold is set relative to the maximum volume setting plus the attack threshold.

**Table 7. Channel Limiter Mapping as a function of CxLS bits.**

| CxLS(1,0) | Channel Limiter Mapping         |
|-----------|---------------------------------|
| 00        | Channel has limiting disabled   |
| 01        | Channel is mapped to limiter #1 |
| 10        | Channel is mapped to limiter #2 |

**Table 8. Limiter Attack Rate as a function of LxA bits.**

| LxA(3..0) | Attack Rate dB/ms |
|-----------|-------------------|
| 0001      |                   |
| 0010      |                   |
| 0011      |                   |
| LxA(3..0) | 1.3536            |
| 0000      | 0.9024            |
| 0110      | 0.4512            |
| 0111      | 0.2256            |
| 1000      | 0.1504            |
| 1001      | 0.1123            |
| 1010      | 0.0902            |
| 1011      | 0.0752            |
| 1100      | 0.0645            |
| 1101      | 0.0564            |
| 1110      | 0.0501            |
| 1111      | 0.0451            |

note: Shaded areas are Default Settings

**Table 9. Limiter Release Rate and Uncompression Threshold as a function of LxR bits**

| LxR(3..0) | Release Rate dB/ms |
|-----------|--------------------|
| 0000      | 0.5116             |
| 0001      | 0.1370             |
| 0010      | 0.0744             |
| 0011      | 0.0499             |
| 0100      | 0.0360             |
| 0101      | 0.0299             |
| 0110      | 0.0264             |
| 0111      | 0.0208             |
| 1000      | 0.0198             |
| 1001      | 0.0172             |
| 1010      | 0.0147             |
| 1011      | 0.0137             |
| 1100      | 0.0134             |
| 1101      | 0.0117             |
| 1110      | 0.0110             |
| 1111      | 0.0104             |

**Table 10. Limiter Attack Threshold as a function of LxAT bits.**

| LxAT(3..0) | AC(dB relative to FS) | DRC(db relative to Volume) |
|------------|-----------------------|----------------------------|
| 0000       | -12                   | -22                        |
| 0001       | -10                   | -20                        |
| 0010       | -8                    | -18                        |
| 0011       | -6                    | -16                        |
| 0100       | -4                    | -14                        |
| 0101       | -2                    | -12                        |
| 0110       | 0                     | -10                        |
| 0111       | +2                    | -8                         |
| 1000       | +3                    | -7                         |
| 1001       | +4                    | -6                         |
| 1010       | +5                    | -5                         |
| 1011       | +6                    | -4                         |
| 1100       | +7                    | -3                         |
| 1101       | +8                    | -2                         |
| 1110       | +9                    | -1                         |
| 1111       | +10                   | 0                          |



Table 11. Limiter Release Threshold as a function of LxRT bits

| LxRT(3..0) | AC(dB relative to FS) | DRC(db relative to Volume + LxAT) |
|------------|-----------------------|-----------------------------------|
| 0000       | •                     | •                                 |
| 0001       | -23dB                 | -33dB                             |
| 0010       | -16.9dB               | -26.9dB                           |
| 0011       | -13.4dB               | -23.4dB                           |
| 0100       | -10.9dB               | -20.9dB                           |
| 0101       | -9.0dB                | -19.0dB                           |
| 0110       | -7.4dB                | -17.4dB                           |
| 0111       | -6.0dB                | -16.0dB                           |
| 1000       | -4.9dB                | -14.9dB                           |
| 1001       | -3.8dB                | -13.8dB                           |
| 1010       | -2.9dB                | -12.9dB                           |
| 1011       | -2.1dB                | -12.1dB                           |
| 1100       | -1.3dB                | -11.3dB                           |
| 1101       | -0.65dB               | -10.65dB                          |
| 1110       | 0dB                   | -10dB                             |
| 1111       | +0.6dB                | -9.4dBdB                          |

## 3.27 Bass and Treble Tone Control(address 1Bh)

| BIT  | D7   | D6   | D5   | D4   | D3   | D2   | D1   | D0   |
|------|------|------|------|------|------|------|------|------|
| NAME | TTC3 | TTC2 | TTC1 | TTC0 | BTC3 | BTC2 | BTC1 | BTC0 |
| RST  | 0    | 1    | 1    | 1    | 0    | 1    | 1    | 1    |

The STA308 contains bass and treble tone control adjustments. These are selectable from +12dB to -12dB of boost or cut. These are 1st order shelving filters with a corner frequency of 150Hz for bass and 3kHz for treble. Any gain introduced in the tone controls will carry through to the volume and limiting block without saturation.

Table 12. Tone Control Boost/Cut as a function of BTC and TTC bits

| BTC(3..0)/TTC(3..0) | Boost/Cut |
|---------------------|-----------|
| 0000                | -12dB     |
| 0001                | -12dB     |
| ...                 | ...       |
| 0111                | -4dB      |
| 0110                | -2dB      |
| 0111                | 0dB       |
| 1000                | +2dB      |
| 1001                | +4dB      |
| ...                 | ...       |
| 1101                | +12dB     |
| 1110                | +12dB     |
| 1111                | +12dB     |

**3.28 Coefficient Address Register (address 1Ch)**

| BIT  | D7   | D6   | D5   | D4   | D3   | D2   | D1   | D0   |
|------|------|------|------|------|------|------|------|------|
| NAME | CFA7 | CFA6 | CFA5 | CFA4 | CFA3 | CFA2 | CFA1 | CFA0 |
| RST  | 0    | 0    | 0    | 0    | 0    | 0    | 0    | 0    |

**3.29 Coefficient b2 Data Register Bits 23..16 (address 1Dh)**

| BIT  | D7    | D6    | D5    | D4    | D3    | D2    | D1    | D0    |
|------|-------|-------|-------|-------|-------|-------|-------|-------|
| NAME | C1B23 | C1B22 | C1B21 | C1B20 | C1B19 | C1B18 | C1B17 | C1B16 |
| RST  | 0     | 0     | 0     | 0     | 0     | 0     | 0     | 0     |

**3.30 Coefficient b2 Data Register Bits 15..8 (address 1Eh)**

| BIT  | D7    | D6    | D5    | D4    | D3    | D2    | D1   | D0   |
|------|-------|-------|-------|-------|-------|-------|------|------|
| NAME | C1B15 | C1B14 | C1B13 | C1B12 | C1B11 | C1B10 | C1B9 | C1B8 |
| RST  | 0     | 0     | 0     | 0     | 0     | 0     | 0    | 0    |

**3.31 Coefficient b2 Data Register Bits 7..0 (address 1Fh)**

| BIT  | D7   | D6   | D5   | D4   | D3   | D2   | D1   | D0   |
|------|------|------|------|------|------|------|------|------|
| NAME | C1B7 | C1B6 | C1B5 | C1B4 | C1B3 | C1B2 | C1B1 | C1B0 |
| RST  | 0    | 0    | 0    | 0    | 0    | 0    | 0    | 0    |

**3.32 Coefficient b0 Data Register Bits 23..16 (address 20h)**

| BIT  | D7    | D6    | D5    | D4    | D3    | D2    | D1    | D0    |
|------|-------|-------|-------|-------|-------|-------|-------|-------|
| NAME | C2B23 | C2B22 | C2B21 | C2B20 | C2B19 | C2B18 | C2B17 | C2B16 |
| RST  | 0     | 0     | 0     | 0     | 0     | 0     | 0     | 0     |

**3.33 Coefficient b0 Data Register Bits 15..8 (address 21h)**

| BIT  | D7    | D6    | D5    | D4    | D3    | D2    | D1   | D0   |
|------|-------|-------|-------|-------|-------|-------|------|------|
| NAME | C2B15 | C2B14 | C2B13 | C2B12 | C2B11 | C2B10 | C2B9 | C2B8 |
| RST  | 0     | 0     | 0     | 0     | 0     | 0     | 0    | 0    |

**3.34 Coefficient b0 Data Register Bits 7..0 (address 22h)**

| BIT  | D7   | D6   | D5   | D4   | D3   | D2   | D1   | D0   |
|------|------|------|------|------|------|------|------|------|
| NAME | C2B7 | C2B6 | C2B5 | C2B4 | C2B3 | C2B2 | C2B1 | C2B0 |
| RST  | 0    | 0    | 0    | 0    | 0    | 0    | 0    | 0    |

**3.35 Coefficient a2 Data Register Bits 23..16 (address 23h)**

| BIT  | D7    | D6    | D5    | D4    | D3    | D2    | D1    | D0    |
|------|-------|-------|-------|-------|-------|-------|-------|-------|
| NAME | C3B23 | C3B22 | C3B21 | C3B20 | C3B19 | C3B18 | C3B17 | C3B16 |
| RST  | 0     | 0     | 0     | 0     | 0     | 0     | 0     | 0     |

**3.36 Coefficient a2 Data Register Bits 15..8 (address 24h)**

| BIT  | D7    | D6    | D5    | D4    | D3    | D2    | D1   | D0   |
|------|-------|-------|-------|-------|-------|-------|------|------|
| NAME | C3B15 | C3B14 | C3B13 | C3B12 | C3B11 | C3B10 | C3B9 | C3B8 |
| RST  | 0     | 0     | 0     | 0     | 0     | 0     | 0    | 0    |

**3.37 Coefficient a2 Data Register Bits 7..0 (address 25h)**

| BIT  | D7   | D6   | D5   | D4   | D3   | D2   | D1   | D0   |
|------|------|------|------|------|------|------|------|------|
| NAME | C3B7 | C3B6 | C3B5 | C3B4 | C3B3 | C3B2 | C3B1 | C3B0 |
| RST  | 0    | 0    | 0    | 0    | 0    | 0    | 0    | 0    |

**3.38 Coefficient a1 Data Register Bits 23..16 (address 26h)**

| BIT  | D7    | D6    | D5    | D4    | D3    | D2    | D1    | D0    |
|------|-------|-------|-------|-------|-------|-------|-------|-------|
| NAME | C4B23 | C4B22 | C4B21 | C4B20 | C4B19 | C4B18 | C4B17 | C4B16 |
| RST  | 0     | 0     | 0     | 0     | 0     | 0     | 0     | 0     |

**3.39 Coefficient a1 Data Register Bits 15..8 (address 27h)**

| BIT  | D7    | D6    | D5    | D4    | D3    | D2    | D1   | D0   |
|------|-------|-------|-------|-------|-------|-------|------|------|
| NAME | C4B15 | C4B14 | C4B13 | C4B12 | C4B11 | C4B10 | C4B9 | C4B8 |
| RST  | 0     | 0     | 0     | 0     | 0     | 0     | 0    | 0    |

**3.40 Coefficient a1 Data Register Bits 7..0 (address 28h)**

| BIT  | D7   | D6   | D5   | D4   | D3   | D2   | D1   | D0   |
|------|------|------|------|------|------|------|------|------|
| NAME | C4B7 | C4B6 | C4B5 | C4B4 | C4B3 | C4B2 | C4B1 | C4B0 |
| RST  | 0    | 0    | 0    | 0    | 0    | 0    | 0    | 0    |

**3.41 Coefficient b1 Data Register Bits 23..16 (address 29h)**

| BIT  | D7    | D6    | D5    | D4    | D3    | D2    | D1    | D0    |
|------|-------|-------|-------|-------|-------|-------|-------|-------|
| NAME | C5B23 | C5B22 | C5B21 | C5B20 | C5B19 | C5B18 | C5B17 | C5B16 |
| RST  | 0     | 0     | 0     | 0     | 0     | 0     | 0     | 0     |

**3.42 Coefficient b1 Data Register Bits 15..8 (address 2Ah)**

| BIT  | D7    | D6    | D5    | D4    | D3    | D2    | D1   | D0   |
|------|-------|-------|-------|-------|-------|-------|------|------|
| NAME | C5B15 | C5B14 | C5B13 | C5B12 | C5B11 | C5B10 | C5B9 | C5B8 |
| RST  | 0     | 0     | 0     | 0     | 0     | 0     | 0    | 0    |

**3.43 Coefficient b1 Data Register Bits 7..0 (address 2Bh)**

| BIT  | D7   | D6   | D5   | D4   | D3   | D2   | D1   | D0   |
|------|------|------|------|------|------|------|------|------|
| NAME | C5B7 | C5B6 | C5B5 | C5B4 | C5B3 | C5B2 | C5B1 | C5B0 |
| RST  | 0    | 0    | 0    | 0    | 0    | 0    | 0    | 0    |

**3.44 Coefficient Write Control Register (address 2Ch)**

| BIT  | D7 | D6 | D5 | D4 | D3 | D2 | D1 | D0 |
|------|----|----|----|----|----|----|----|----|
| NAME |    |    |    |    |    |    | WA | W1 |
| RST  |    |    |    |    |    |    |    |    |

Coefficients for EQ and Bass Management are handled internally in the STA308 via RAM. Access to this RAM is available to the user via an I2C register interface. A collection of I2C registers is dedicated to this function. One contains a coefficient base address, five sets of three store the values of the 24-bit coefficients to be written or that were read, and one contains bits used to control the writing of the coefficient(s) to RAM. The following are step instructions for reading and writing coefficients.

**Reading a coefficient from RAM**

- write 8-bit address to I2C register 1Ch
- read top 8-bits of coefficient in I2C address 1Dh
- read middle 8-bits of coefficient in I2C address 1Eh
- read bottom 8-bits of coefficient in I2C address 1Fh

**Writing a single coefficient to RAM**

- write 8-bit address to I2C register 1Ch
- write top 8-bits of coefficient in I2C address 1Dh
- write middle 8-bits of coefficient in I2C address 1Eh
- write bottom 8-bits of coefficient in I2C address 1Fh
- write 1 to W1 bit in I2C address 2Bh

**Writing a set of coefficients to RAM**

- write 8-bit starting address to I2C register 1Ch
- write top 8-bits of coefficient b2 in I2C address 1Dh
- write middle 8-bits of coefficient b2 in I2C address 1Eh
- write bottom 8-bits of coefficient b2 in I2C address 1Fh
- write top 8-bits of coefficient b0 in I2C address 20h
- write middle 8-bits of coefficient b0 in I2C address 21h
- write bottom 8-bits of coefficient b0 in I2C address 22h
- write top 8-bits of coefficient a2 in I2C address 23h
- write middle 8-bits of coefficient a2 in I2C address 24h
- write bottom 8-bits of coefficient a2 in I2C address 25h
- write top 8-bits of coefficient a1 in I2C address 26h
- write middle 8-bits of coefficient a1 in I2C address 27h
- write bottom 8-bits of coefficient a1 in I2C address 28h
- write top 8-bits of coefficient b1 in I2C address 29h
- write middle 8-bits of coefficient b1 in I2C address 2Ah
- write bottom 8-bits of coefficient b1 in I2C address 2Bh
- write 1 to WA bit in I2C address 2Ch

The mechanism for writing a set of coefficients to RAM provides a method of updating the five coefficients cor-

responding to a given biquad (filter) simultaneously to avoid possible unpleasant acoustic side effects. When using this technique, the 8-bit address would specify the address of the biquad b2 coefficient (e.g. 0, 5, 10, 15, ..., 50, ... 195 decimal), and the STA308 will generate the RAM addresses as offsets from this base value to write the complete set of coefficient data.

### Equalization:

**Figure 3. Data Flow for single channel Biquad / Bass / Treble block.:**

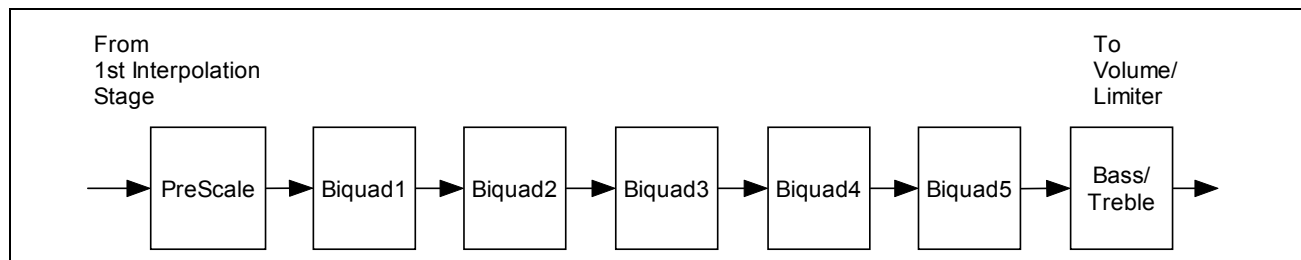

Five user-programmable 28-bit biquads are available per channel in the STA308. These biquads run at 192kHz for 48kHz, 96kHz, or 192kHz input and at 176.4kHz for 44.1kHz, 88.2kHz, and 176.4kHz input. The PreScale block is used for attenuation when filters are to be designed that boost frequencies above 0dBFS. This is a single 28-bit signed multiply, with 800000h = -1 and 7FFFFFFh = 0.9999998808. These values are labeled CxPS, with x representing the channel. The biquads use this equation:

$$Y[n] = 2(b0/2)X[n] + 2(b1/2)X[n-1] + b2X[n-2] - 2(a1/2)Y[n-1] - a2Y[n-2]$$

$$= b0X[n] + b1X[n-1] + b2X[n-2] - a1Y[n-1] - a2Y[n-2]$$

$Y[n]$  represents the output and  $X[n]$  represents the input. Coefficients are defined in the following manner:

$$CxHx0 = b2$$

$$CxHx1 = b0/2$$

$$CxHx2 = -a2$$

$$CxHx3 = -a1/2$$

$$CxHx4 = b1/2$$

The first x represents the channel and the second the biquad number. For example C3H41 is the b0/2 coefficient in the fourth series biquad in channel 3. The biquad link bit allows all channels to use the coefficients of channel 1.

### Bass Management

Channel 6 provides the ability to scale and mix all channels before the biquad block. This allows for information from any channel to be redirected to this channel and then filtered appropriately for a subwoofer application. When the BME bit is set (bit D5 of Configuration Register A, at address 00h) the input to the biquad section is routed from the scale and mix block instead of the normal channel 6 1st stage interpolation output.

Eight scaling coefficients are provided to perform this function. They are labeled CxBMS with x representing the channel that is being scaled. Each input channel is multiplied by its corresponding scale factor and summed. The output of the summation is the output of the scale and mix block.

**Post-Scale**

The STA308 provides one additional multiplication after the last interpolation stage and before the distortion compensation on each channel. This is a 24-bit signed fractional multiply. The scale factor for this multiply is loaded into RAM using the same I2C registers as the biquad coefficients and the bass-management. All channels can use the channel 1 by setting the post-scale link bit.

**RAM Block for Biquads and Bass Management:**

| Index (Decimal) | Index (Hex) |                         | Coefficient              | Default  |
|-----------------|-------------|-------------------------|--------------------------|----------|
| 0               | 00h         | Channel 1 - Biquad 1    | C1H10(b <sub>2</sub> )   | 000000h  |
| 1               | 01h         |                         | C1H11(b <sub>0/2</sub> ) | 3FFFFFFh |
| 2               | 02h         |                         | C1H12(a <sub>2</sub> )   | 000000h  |
| 3               | 03h         |                         | C1H13(a <sub>1/2</sub> ) | 000000h  |
| 4               | 04h         |                         | C1H14(b <sub>1/2</sub> ) | 000000h  |
| 5               | 05h         | Channel 1 - Biquad 2    | C1H20                    | 000000h  |
| ...             | ...         | ...                     | ...                      | ...      |
| 24              | 18h         | Channel 1 - Biquad 5    | C1H54                    | 000000h  |
| 25              | 19h         | Channel 2 - Biquad 1    | C2H10                    | 000000h  |
| 26              | 1Ah         |                         | C2H11                    | 3FFFFFFh |
| ...             | ...         | ...                     | ...                      | ...      |
| 45              | 2Dh         | Distortion Compensation | DCC 23...0               | 000000h  |
| ...             | ...         | ...                     | ...                      | ...      |
| 49              | 31h         | Channel 2 - Biquad 5    | C2H54                    | 000000h  |
| 50              | 32h         | Channel 3 - Biquad 1    | C3H10                    | 000000h  |
| ...             | ...         | ...                     | ...                      | ...      |
| 199             | C7h         | Channel 8 - Biquad 5    | C8H54                    | 000000h  |
| 200             | C8h         | Channel 1 - Pre-Scale   | C1PS                     | 800000h  |
| 201             | C9h         | Channel 2 - Pre-Scale   | C2PS                     | 800000h  |
| 202             | CAh         | Channel 3 - Pre-Scale   | C3PS                     | 800000h  |
| ...             | ...         | ...                     | ...                      | ...      |
| 207             | CFh         | Channel 8 - Pre-Scale   | C8PS                     | 800000h  |
| 208             | D0h         | Channel 1 - BassM Scale | C1BMS                    | 000000h  |
| 209             | D1h         | Channel 2 - BassM Scale | C2BMS                    | 000000h  |
| ...             | ...         | ...                     | ...                      | ...      |
| 215             | D7h         | Channel 8 - BassM Scale | C8BMS                    | 000000h  |
| 216             | D8h         | Channel 1 - Post-Scale  | C1PS                     | 800000h  |
| 217             | D9h         | Channel 2 - Post-Scale  | C2PS                     | 800000h  |
| ...             | ...         | ...                     | ...                      | ...      |
| 223             | DFh         | Channel 8 - Post-Scale  | C8PS                     | 800000h  |
| 224             | F0h         | Not Used                |                          |          |
| ...             | ...         | ...                     | ...                      | ...      |
| 255             | FFh         | Not Used                |                          |          |

| DIM. | mm                                |       |       | inch   |        |        |
|------|-----------------------------------|-------|-------|--------|--------|--------|
|      | MIN.                              | TYP.  | MAX.  | MIN.   | TYP.   | MAX.   |
| A    |                                   |       | 1.60  |        |        | 0.063  |
| A1   | 0.05                              |       | 0.15  | 0.002  |        | 0.006  |
| A2   | 1.35                              | 1.40  | 1.45  | 0.053  | 0.055  | 0.057  |
| B    | 0.17                              | 0.22  | 0.27  | 0.0066 | 0.0086 | 0.0106 |
| C    | 0.09                              |       |       | 0.0035 |        |        |
| D    | 11.80                             | 12.00 | 12.20 | 0.464  | 0.472  | 0.480  |
| D1   | 9.80                              | 10.00 | 10.20 | 0.386  | 0.394  | 0.401  |
| D3   |                                   | 7.50  |       |        | 0.295  |        |
| e    |                                   | 0.50  |       |        | 0.0197 |        |
| E    | 11.80                             | 12.00 | 12.20 | 0.464  | 0.472  | 0.480  |
| E1   | 9.80                              | 10.00 | 10.20 | 0.386  | 0.394  | 0.401  |
| E3   |                                   | 7.50  |       |        | 0.295  |        |
| L    | 0.45                              | 0.60  | 0.75  | 0.0177 | 0.0236 | 0.0295 |
| L1   |                                   | 1.00  |       |        | 0.0393 |        |
| K    | 0° (min.), 3.5° (min.), 7° (max.) |       |       |        |        |        |
| ccc  |                                   |       | 0.080 |        |        | 0.0031 |

**OUTLINE AND MECHANICAL DATA**

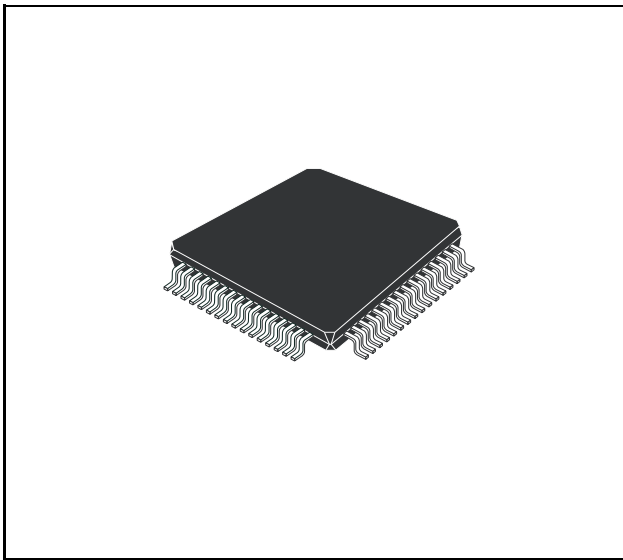

**TQFP64 (10 x 10 x 1.4mm)**

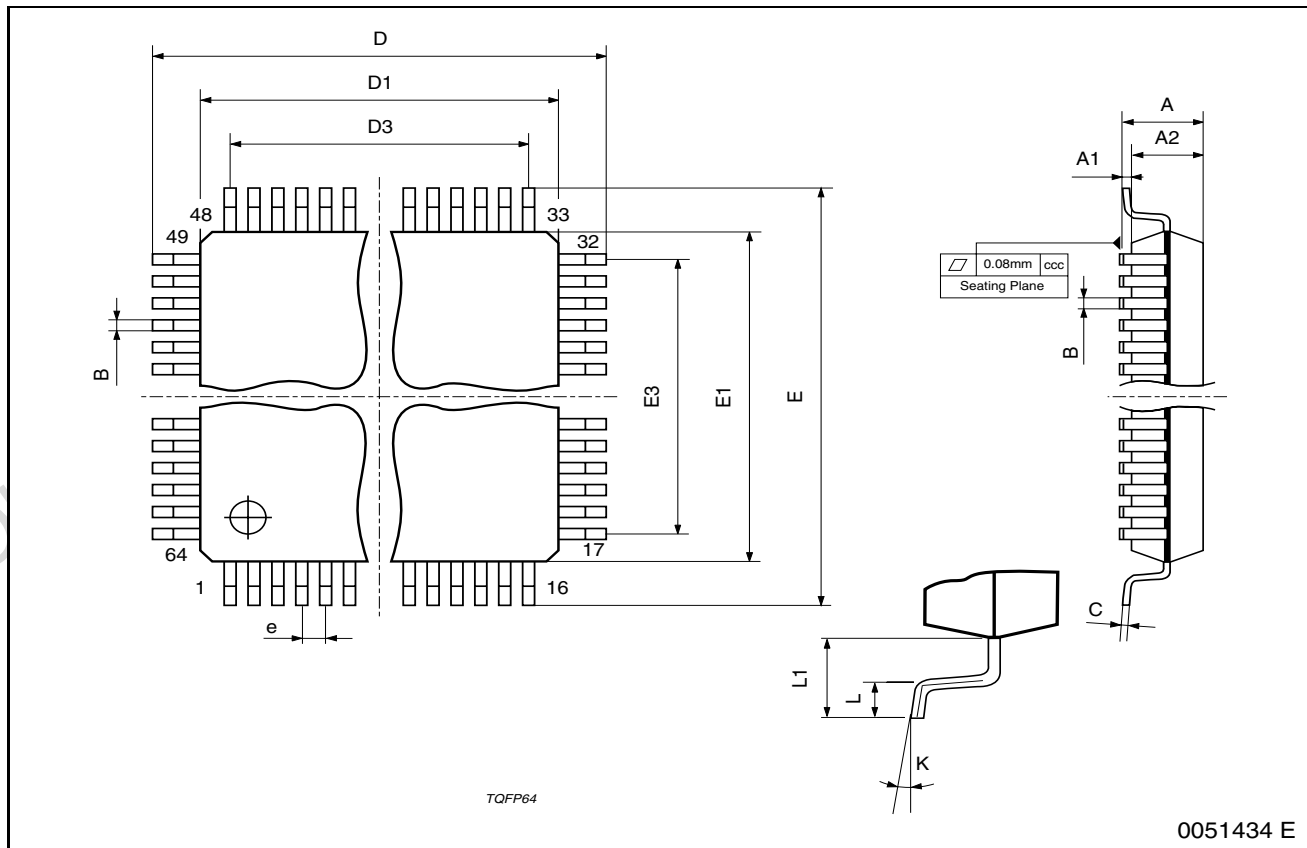

**4.0 REVISION HISTORY****Table 13. Revision History**

| <b>Date</b> | <b>Revision</b> | <b>Description of Changes</b>                     |
|-------------|-----------------|---|
| April 2004  | 2               | Updates not recorded                              |
| 30-Apr-2010 | 3               | Removed "Preliminary data" status from cover page |

Obsolete Product(s) - Obsolete Product(s)



**Please Read Carefully:**

Information in this document is provided solely in connection with ST products. STMicroelectronics NV and its subsidiaries ("ST") reserve the right to make changes, corrections, modifications or improvements, to this document, and the products and services described herein at any time, without notice.

All ST products are sold pursuant to ST's terms and conditions of sale.

Purchasers are solely responsible for the choice, selection and use of the ST products and services described herein, and ST assumes no liability whatsoever relating to the choice, selection or use of the ST products and services described herein.

No license, express or implied, by estoppel or otherwise, to any intellectual property rights is granted under this document. If any part of this document refers to any third party products or services it shall not be deemed a license grant by ST for the use of such third party products or services, or any intellectual property contained therein or considered as a warranty covering the use in any manner whatsoever of such third party products or services or any intellectual property contained therein.

**UNLESS OTHERWISE SET FORTH IN ST'S TERMS AND CONDITIONS OF SALE ST DISCLAIMS ANY EXPRESS OR IMPLIED WARRANTY WITH RESPECT TO THE USE AND/OR SALE OF ST PRODUCTS INCLUDING WITHOUT LIMITATION IMPLIED WARRANTIES OF MERCHANTABILITY, FITNESS FOR A PARTICULAR PURPOSE (AND THEIR EQUIVALENTS UNDER THE LAWS OF ANY JURISDICTION), OR INFRINGEMENT OF ANY PATENT, COPYRIGHT OR OTHER INTELLECTUAL PROPERTY RIGHT.**

**UNLESS EXPRESSLY APPROVED IN WRITING BY AN AUTHORIZED ST REPRESENTATIVE, ST PRODUCTS ARE NOT RECOMMENDED, AUTHORIZED OR WARRANTED FOR USE IN MILITARY, AIR CRAFT, SPACE, LIFE SAVING, OR LIFE SUSTAINING APPLICATIONS, NOR IN PRODUCTS OR SYSTEMS WHERE FAILURE OR MALFUNCTION MAY RESULT IN PERSONAL INJURY, DEATH, OR SEVERE PROPERTY OR ENVIRONMENTAL DAMAGE. ST PRODUCTS WHICH ARE NOT SPECIFIED AS "AUTOMOTIVE GRADE" MAY ONLY BE USED IN AUTOMOTIVE APPLICATIONS AT USER'S OWN RISK.**

Resale of ST products with provisions different from the statements and/or technical features set forth in this document shall immediately void any warranty granted by ST for the ST product or service described herein and shall not create or extend in any manner whatsoever, any liability of ST.

ST and the ST logo are trademarks or registered trademarks of ST in various countries.

Information in this document supersedes and replaces all information previously supplied.

The ST logo is a registered trademark of STMicroelectronics. All other names are the property of their respective owners.

© 2010 STMicroelectronics - All rights reserved

STMicroelectronics group of companies

Australia - Belgium - Brazil - Canada - China - Czech Republic - Finland - France - Germany - Hong Kong - India - Israel - Italy - Japan - Malaysia - Malta - Morocco - Philippines - Singapore - Spain - Sweden - Switzerland - United Kingdom - United States of America

[www.st.com](http://www.st.com)

