

FEATURES

- **HIGH ISOLATION VOLTAGE**
BV: 5 k V_{r.m.s.} MIN
- **LONG CREEPAGE AND CLEARANCE DISTANCE**
8 mm MIN
- **HIGH COLLECTOR TO EMITTER VOLTAGE**
V_{CEO} = 40 V MIN
- **HIGH SPEED SWITCHING**
tr, tf = 100 μs TYP
- **HIGH CURRENT TRANSFER RATIO**
CTR: 2000% TYP
- **6 PIN DUAL IN-LINE PACKAGE**
- **TAPING IS AVAILABLE**

DESCRIPTION

PS2653 and PS2654 are optically coupled isolators containing a GaAs light emitting diode and an NPN silicon Darlington-connected phototransistor in a plastic DIP (Dual In-Line Package). PS2653 has a base pin and PS2654 has no base pin. Creepage distance and clearance of leads are over 8 millimeters. PS2653L2 and PS2654L2 are surface mount type.

APPLICATIONS

Interface circuit for various instrumentations and control equipment.

- AC LINE/DIGITAL LOGIC
- DIGITAL LOGIC INTERFACE
- TWISTED PAIR LINE RECEIVER
- TELEPHONE/TELEGRAPH LINE RECEIVER
- HIGH FREQUENCY POWER SUPPLY FEEDBACK CONTROL
- RELAY CONTACT MONITOR
- POWER SUPPLY MONITOR

ELECTRICAL CHARACTERISTICS (T_A = 25°C)

PART NUMBER			PS2653, PS2653L2, PS2654, PS2654L2			
	SYMBOLS	PARAMETERS	UNITS	MIN	TYP	MAX
Diode	V _F	Forward Voltage, I _F = 10 mA	V		1.1	1.4
	I _R	Reverse Current, V _R = 5 V	μA			5
	C	Junction Capacitance, V = 0, f = 1.0 MHz	pF		30	
Transistor	I _{CEO}	Collector to Emitter Dark Current, V _{CE} = 40 V, I _F = 0	nA			400
	BV _{CEO}	Collector to Emitter Breakdown Voltage, I _C = 1 mA, I _B = 0	V	40		
	BV _{ECO}	Emitter to Collector Breakdown Voltage, I _E = 100 μA, I _B = 0	V	6		
Coupled	CTR	Current Transfer Ratio ¹ , I _F = 1 mA, V _{CE} = 2 V	%	200	2000	
	V _{CE(sat)}	Collector Saturation Voltage, I _F = 1 mA, I _C = 2 mA	V			1.0
	R ₁₋₂	Isolation Resistance, V _{in-out} = 1.0 kV	Ω	10 ¹¹		
	C ₁₋₂	Isolation Capacitance, V = 0, f = 1.0 MHz	pF		0.6	
	tr	Rise Time ² , V _{CC} = 10 V, I _C = 10 mA	μs		3	
tf	Fall Time ² , V _{CC} = 10 V, I _C = 10 mA	μs		5		

1. CTR rank

KD : 2300 to (%)
LD : 700 to 3400 (%)
MD : 200 to 1000 (%)

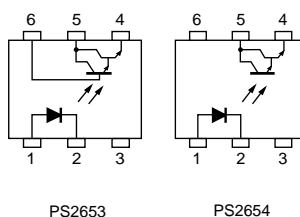

2. Test Circuit for Switching Time

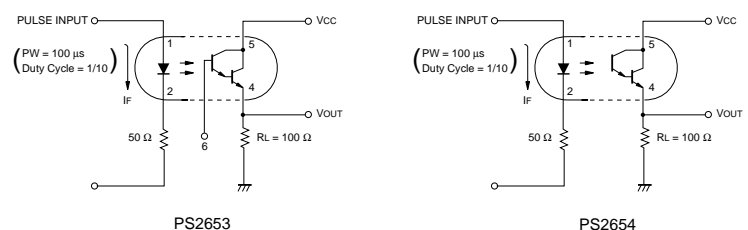

PS2653, PS2653L2, PS2654, PS2654L2

ABSOLUTE MAXIMUM RATINGS¹ (T_A = 25°C)

SYMBOLS	PARAMETERS	UNITS	RATINGS
Diode			
V _R	Reverse Voltage	V	6
I _F	Forward Current (DC)	mA	80
P _D	Power Dissipation	mW	150
I _F (Peak)	Peak Forward Current PW = 100 μs, Duty Cycle 1%	A	1
Transistor			
V _{CEO}	Collector to Emitter Voltage	V	40
V _{ECO}	Emitter to Collector Voltage	V	6
I _C	Collector Current	mA	200
P _C	Power Dissipation	mW	200
Coupled			
BV	Isolation Voltage ²	V _{r.m.s.}	5000
T _{STG}	Storage Temperature	°C	-55 to +150
T _{OP}	Operating Temperature	°C	-55 to +100

Notes:

1. Operation in excess of any one of these parameters may result in permanent damage.
2. AC voltage for 1 minute at T_A = 25 °C, RH = 60 % between input (Pin No. 1, 2, 3 Common) and output (Pin No. 4, 5, 6 Common).

OUTLINE DIMENSIONS (Units in mm)

PS2653, PS2654

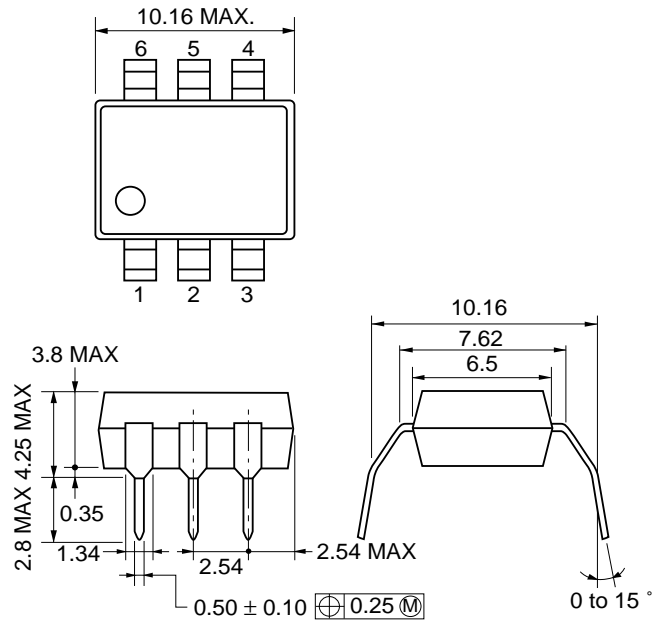

PS2653L2, PS2654L2

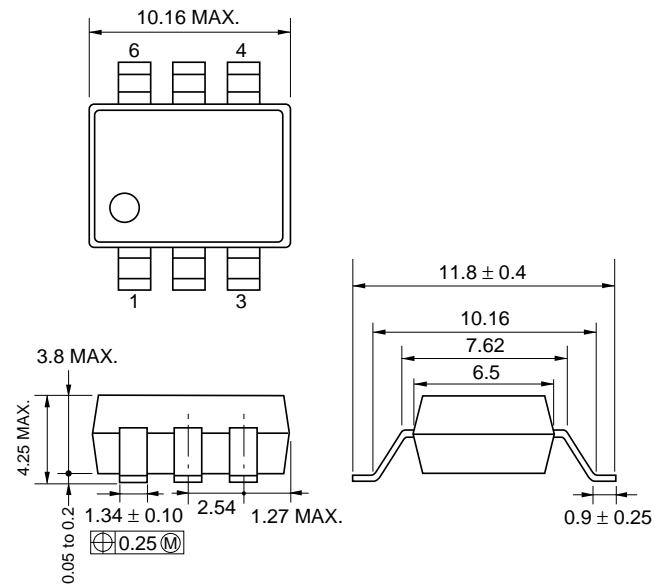

PIN CONNECTION (Top View)

PS2653, PS2653L2

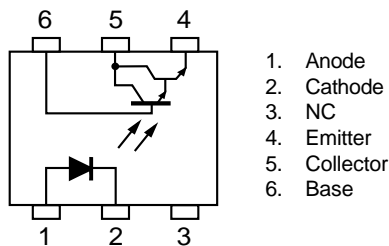

PS2654, PS2654L2

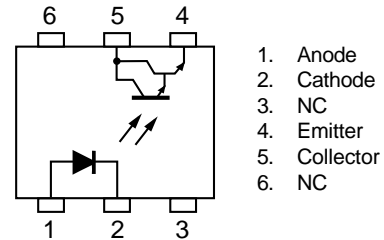

TYPICAL PERFORMANCE CURVES ($T_A = 25\text{ }^\circ\text{C}$)

DIODE POWER DISSIPATION vs. AMBIENT TEMPERATURE

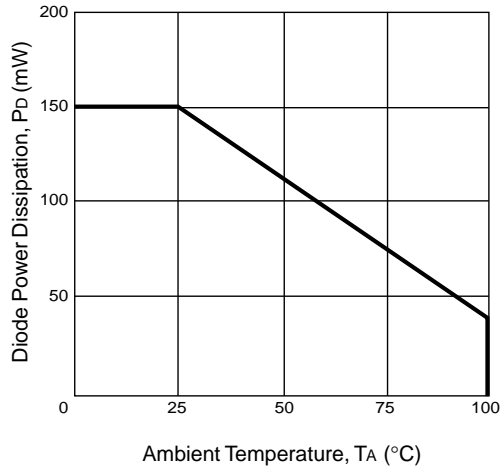

TRANSISTOR POWER DISSIPATION vs. AMBIENT TEMPERATURE

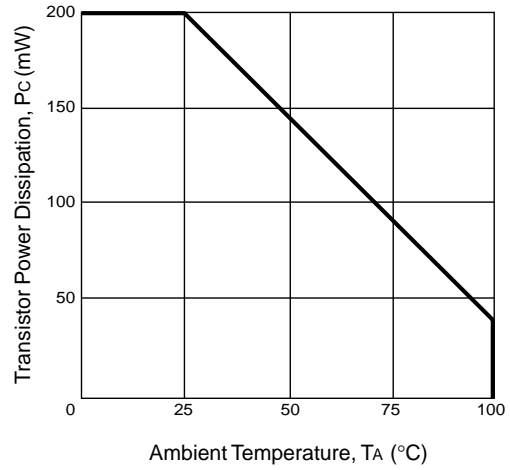

FORWARD CURRENT vs. FORWARD VOLTAGE

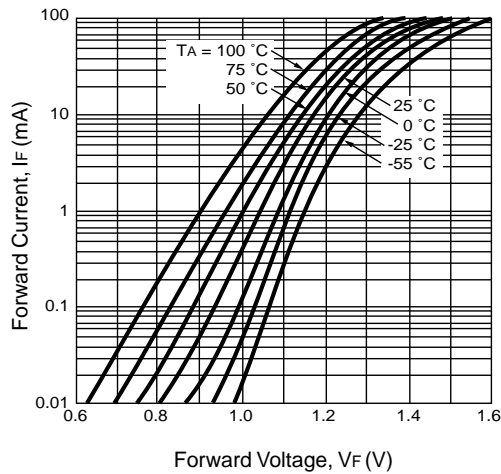

COLLECTOR CURRENT vs. COLLECTOR TO EMITTER VOLTAGE

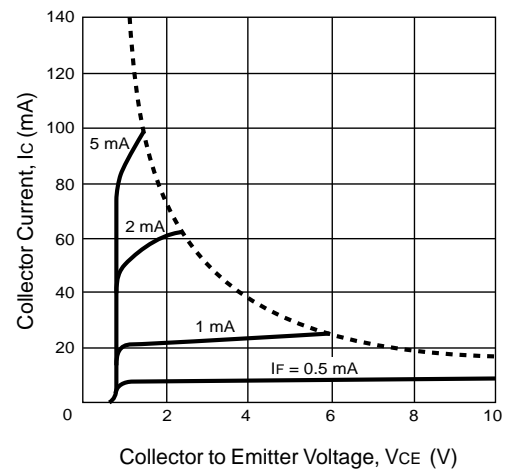

COLLECTOR TO EMITTER DARK CURRENT vs. AMBIENT TEMPERATURE

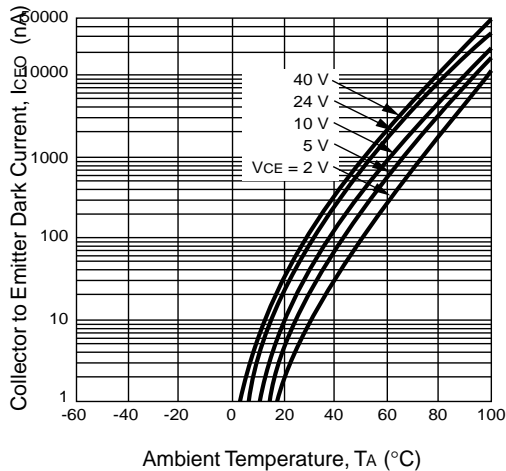

COLLECTOR CURRENT vs. COLLECTOR SATURATION VOLTAGE

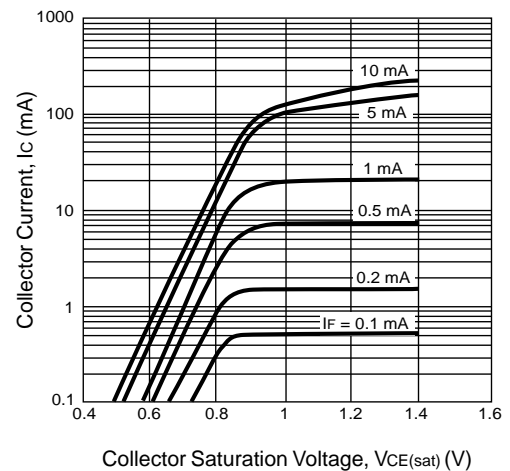

TYPICAL PERFORMANCE CURVES (TA = 25 °C)

