

# OMB5200-120

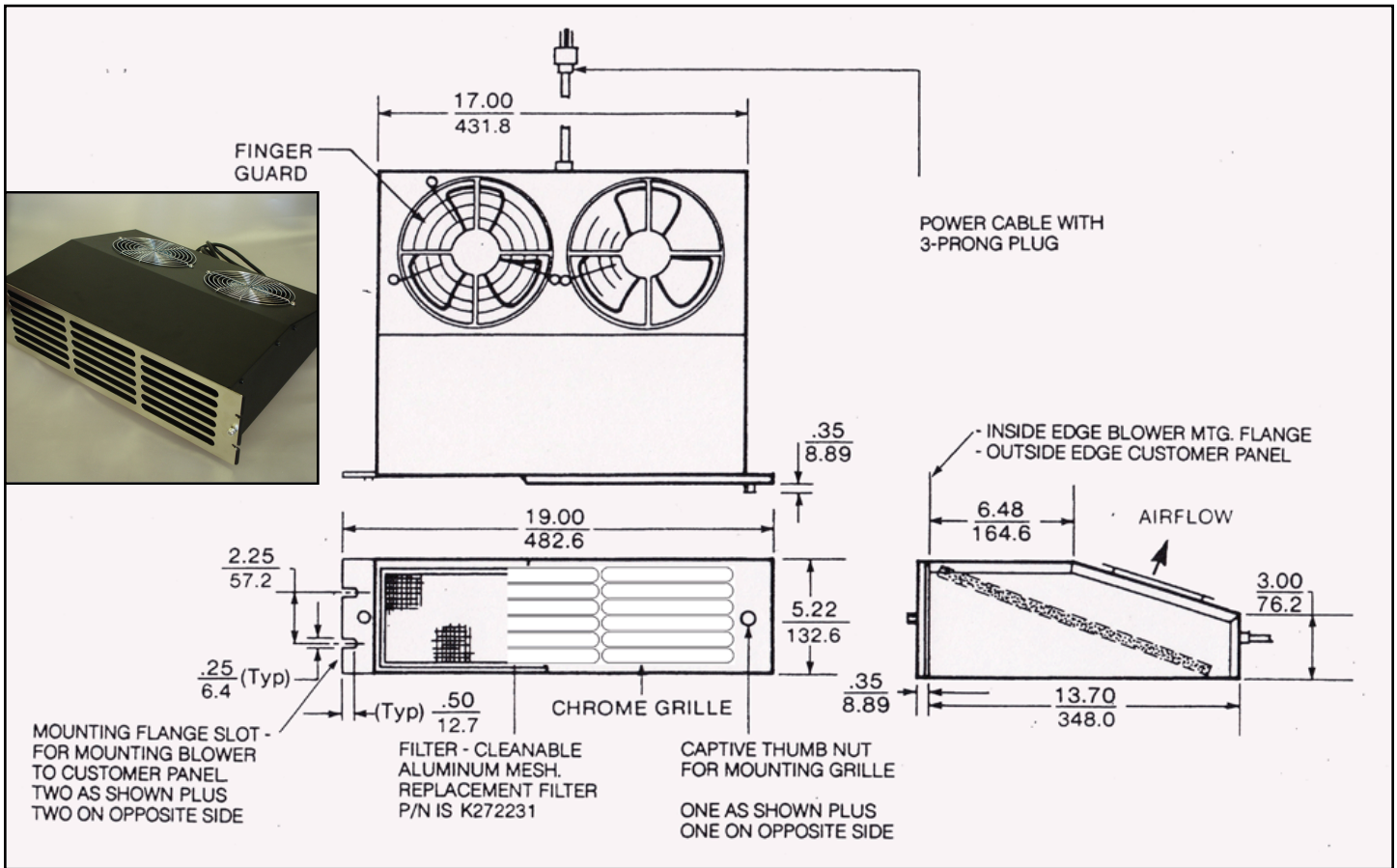

# FanTray - Blower Assembly



Part Number	OMB5200-120
No. of Fans	2
Bearing System	Dual Ball Bearing
Nominal Voltage (60Hz)	115 VDC
Input Power	70 Watts
Rated Speed (RPM)	3500
Airflow (CFM)	340
Noise Level (dB)	57
Life Expectancy	6 years continuous duty @ 25C
Standard	Fits EIA 19" Rack Cabinets