

ASSEMBLY PROCEDURE

- STEP 1: PULL MOUNT TO PANEL - GRIP BREAKS-AWAY AFTER FIXING
- STEP 2: LOCATE AND ASSEMBLE FAN HOUSING

REV.	MODIFICATION.	DATE	DRN
01	Production Release	24/04/07	TC
02	ECN 2007-110	04/07/07	TC
03	ECN 2007-189	29/10/07	SF
04	CO-2010750	29/07/09	OW

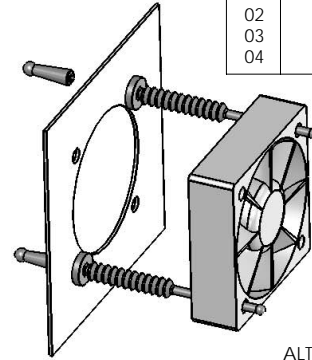

ALTERNATE UNITS FOR REFERENCE ONLY

PART No	PANEL HOLE DIAMETER	PANEL THICKNESS	FAN HOLE DIAMETER	FAN CASE THICKNESS
FMB-1	4.5 - 5.0mm [0.18 - 0.20]	0.8 - 1.6mm [0.03 - 0.06]	4.0 - 4.5mm [0.16 - 0.18]	25 - 51mm [0.98 - 2.01]
FMB-2	4.5 - 5.0mm [0.18 - 0.20]	0.8 - 1.6mm [0.03 - 0.06]	3.2 - 3.5mm [0.13 - 0.14] 4.0 - 4.5mm [0.16 - 0.18]	Up to 10mm [0.40] Max Up to 25mm [0.98]

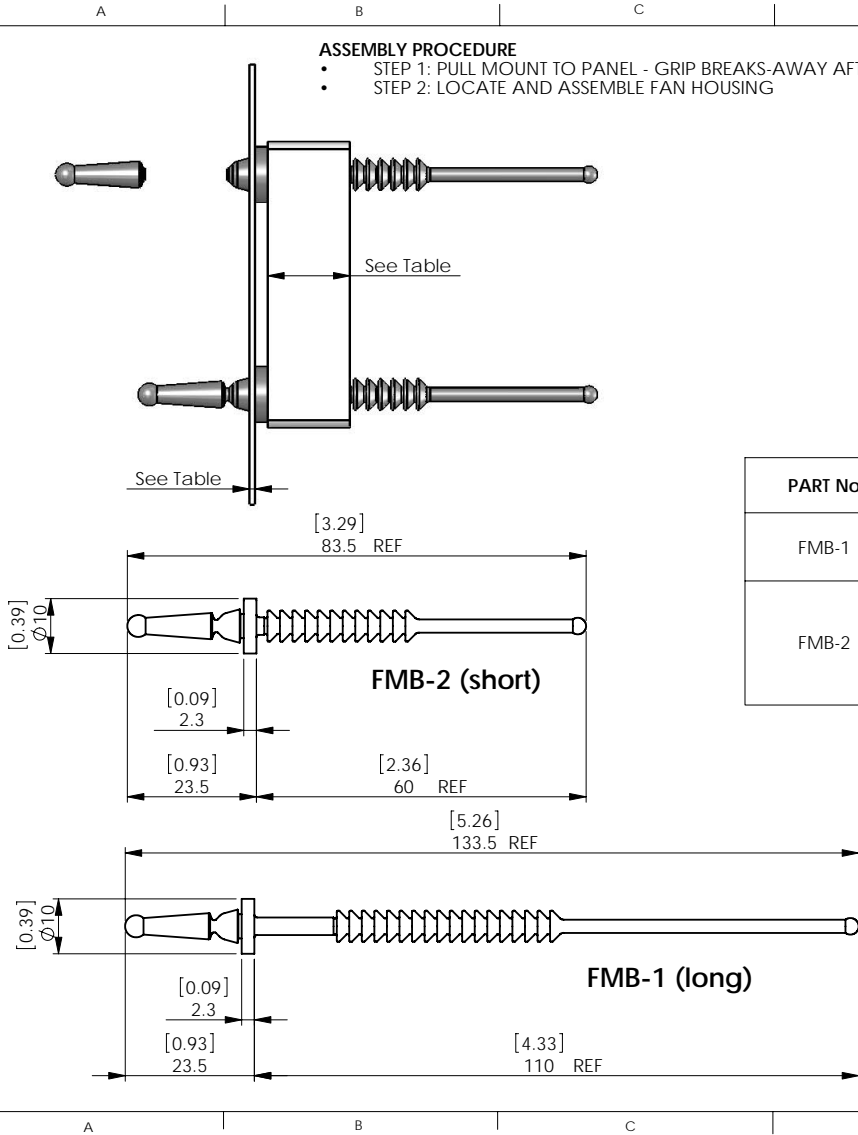

INFORMATION CONTAINED IN THIS DOCUMENT IS CONFIDENTIAL TO RICHCO INTERNATIONAL Co. Ltd. AND MAY NOT BE DISCLOSED OR REPRODUCED IN WHOLE OR PART WITHOUT THEIR WRITTEN CONSENT.

RICHCO, INC.
WWW.RICHCO-INC.COM

ALL DIMENSIONS IN mm & [INCH]
GENERAL TOLERANCES ± 0.25 [0.01]
UNLESS OTHERWISE STATED
1 DECIMAL PLACE ± 0.25 [0.01]
2 DECIMAL PLACES ± 0.10 [0.004]
ANGULAR $\pm 1^\circ$



MATERIAL:
SILICONE RUBBER 40 Sh A (RMS-316)

COLOUR:
BLACK

DESCRIPTION:
BREAK AWAY FAN MOUNT

PART No:
FMB-1 / FMB-2

DRG No:
07-033

NPR No:
2006-312

Mass:(g)
FMB-1 = 1.5g
FMB-2 = 1.1g

SHEET SIZE
A4

DRN
TC

DATE
25/10/06

CHKD
TC

DATE
28/11/06

SCALE
NTS

SHEET No.
2 OF 2

FORM No. 0145/02