

# Ceramic Filters (CERAFIL®)/ Ceramic Discriminators for Communications Equipment



**muRata** *Innovator  
in Electronics*

Murata  
Manufacturing Co., Ltd.

Cat.No.P05E-14

**for EU RoHS Compliant**

- All the products in this catalog comply with EU RoHS.
- EU RoHS is "the European Directive 2002/95/EC on the Restriction of the Use of Certain Hazardous Substances in Electrical and Electronic Equipment".
- For more details, please refer to our website 'Murata's Approach for EU RoHS' (<http://www.murata.com/info/rohs.html>).

# CONTENTS

CERAFIL® and "CERAFIL" in this catalog are the trademarks of Murata Manufacturing Co., Ltd.

			<b>1</b>
			<b>2</b>
<b>Part Numbering</b>	_____	2	
<b>Products Guide</b>	_____	4	
<b>1 CERAFIL® kHz SMD Type SFPKA Series</b>	_____	5	
<b>2 CERAFIL® kHz SMD Type CFUKG Series</b>	_____	7	
<b>3 CERAFIL® kHz SMD Type CFUKG_X Series</b>	_____	9	
<b>4 CERAFIL® kHz SMD Type CFUKF Series</b>	_____	11	
<b>5 CERAFIL® kHz SMD Type CFWKA Series</b>	_____	13	
<b>6 CERAFIL® kHz SMD Type CFWKA_Y Series</b>	_____	15	
<b>kHz SMD Type CERAFIL® Notice</b>	_____	17	
<b>7 CERAFIL® MHz SMD Type SFECF10M7 Series</b>	_____	19	
<b>8 CERAFIL® MHz SMD Type SFSCE10M7 Series</b>	_____	21	
<b>MHz SMD Type CERAFIL® Notice</b>	_____	23	
<b>SMD Type CERAFIL® Standard Land Pattern Dimensions</b>	_____	27	
<b>kHz SMD Type CERAFIL® Packaging</b>	_____	28	
<b>MHz SMD Type CERAFIL® Packaging</b>	_____	30	
<b>9 CERAFIL® Plastic Case General Use CFULA Series</b>	_____	31	
<b>10 CERAFIL® Plastic Case General Use CFWLA Series</b>	_____	33	
<b>11 CERAFIL® Plastic Case Miniaturized Type CFULB Series</b>	_____	35	
<b>12 CERAFIL® Plastic Case Miniaturized Type CFWLB Series</b>	_____	37	
<b>13 CERAFIL® Plastic Case Group Delay Flat Type CFULA_Y Series</b>	_____	39	
<b>14 CERAFIL® Plastic Case Group Delay Flat Type CFWLA_Y Series</b>	_____	41	
<b>15 CERAFIL® Plastic Case Group Delay Flat Type Miniaturized Type CFULB_Y Series</b>	_____	43	
<b>16 CERAFIL® Plastic Case Group Delay Flat Type CFWLB_Y Series</b>	_____	45	
<b>Plastic Case Type CERAFIL® Minimum Quantity/Notice</b>	_____	47	
<b>17 kHz Type Ceramic Discriminators</b>	_____	48	
<b>18 MHz Type Ceramic Discriminators</b>	_____	61	
<b>Ceramic Discriminators Notice</b>	_____	66	
<b>Ceramic Discriminators Standard Land Pattern Dimensions/Packaging</b>	_____	69	

1

2

3

4

5

6

7

8

9

10

11

12

13

14

15

16

17

18

## ● Part Numbering

### Ceramic Filters (CERAFIL®) for IF

(Part Number)

SF	P	KA	455K	D4A	-R0	
SF	E	CF	10M7	DF00	S0	-R0
①	②	③	④	⑤	⑥	⑦

#### ① Product ID

#### ② Oscillating/Element

Product ID	Oscillating/Element
CF	U 4 Elements Area Expansion mode
	W 6 Elements Area Expansion mode
SF	P 4 Elements Area Expansion mode
	E 2 Elements Thickness Expansion mode
	S 2 Elements Thickness Shear mode
	J 4 Elements Thickness Shear mode

#### ③ Structure/Size

Code	Structure/Size
C□/K□	Chip Type
L□	Lead Type

□ is "A" or subsequent code, which indicates the size. It varies depending on vibration mode and number of elements.

Chip type is only applied for SF series.

#### ④ Nominal Center Frequency

Expressed by four-digit alphanumerics. The unit is hertz (Hz). If the unit is "kHz", it is expressed by three figures plus "K". If the unit is "MHz", a decimal point is expressed by the capital letter "M".

#### ⑤ Product Specification

Code	Product Specification
D4A	Three-digit alphanumerics express pass band width, center frequency tolerance and design type.

SFE/S/J series are expressed by four-digit alphanumerics.

#### ⑥ Individual Specification

Code	Individual Specification Code
001	Expressed by three-digit alphanumerics.

SFE/S/J series are expressed by two-digit alphanumerics.

With standard type, ⑥ is omitted.

#### ⑦ Packaging

Code	Packaging
-B0	Bulk
-R0	Embossed Taping $\phi=180\text{mm}$
-R1	Embossed Taping $\phi=330\text{mm}$
-M0	Magazine

Magazine cassette is applied to lead type and embossed taping to chip type.

### Ceramic Discriminators for IF (kHz)

(Part Number) 

CD	B	LB	450K	C	A	X	16	-B0
①	②	③	④	⑤	⑥	⑦	⑧	⑨

#### ① Product ID

Product ID	
<b>CD</b>	Ceramic Discriminators

#### ② Oscillating

Code	Oscillating
<b>B</b>	Area Expansion mode

#### ③ Structure/Size

Code	Structure/Size
<b>C□/K□</b>	Chip Type
<b>L□</b>	Lead Type

□ is "A" or subsequent code, which indicates the size. It varies depending on vibration mode and number of elements.

#### ④ Nominal Center Frequency

Expressed by four-digit alphanumerics. The unit is in hertz (Hz). Capital letter "K" following three figures expresses the unit of "kHz".

#### ⑤ Detection

Code	Detection
<b>C</b>	Quadrature Detection

#### ⑥ Application

Code	Application
<b>A</b>	Standard
<b>L</b>	Application with coil

#### ⑦ Element Type

Code	Element Type
<b>X</b>	Low-capacitance
<b>Y</b>	High-capacitance

#### ⑧ IC

Code	IC
<b>16</b>	Applicable IC Control code

#### ⑨ Packaging

Code	Packaging
<b>-B0</b>	Bulk
<b>-R0</b>	Embossed Taping $\phi=180\text{mm}$
<b>-R1</b>	Embossed Taping $\phi=330\text{mm}$
<b>-M0</b>	Magazine

Magazine cassette is applied to lead type and embossed taping to chip type. With non-standard products, one letter indicating "Individual Specification" is added between "⑧ Applicable IC" and "⑨ Package Specification code".

### Ceramic Discriminators for IF (MHz)

(Part Number) 

CD	S	CB	10M7	GF	001	-R0
①	②	③	④	⑤	⑥	⑦

#### ① Product ID

Product ID	
<b>CD</b>	Discriminators

#### ② Oscillation

Code	Oscillation
<b>S</b>	Thickness Shear mode

#### ③ Structure/Size

Code	Structure/Size
<b>C□</b>	Chip Type

□ is expressed "A" or subsequent code, which indicates the size.

#### ④ Nominal Center Frequency

Expressed by four-digit alphanumerics. The unit is in hertz (MHz). Decimal point is expressed by capital letter "M".

#### ⑤ Product Specification

Code	Product Specification
<b>GF</b>	Two-digit alphanumerics express type, center frequency, rank, others

#### ⑥ IC

Code	IC
<b>001</b>	Applicable IC Control Code

#### ⑦ Packaging

Code	Packaging
<b>-R0</b>	Embossed Taping $\phi=180\text{mm}$

With non-standard products, an alphanumerics indicating "Individual Specification" is added between "⑥ IC" and "⑦ Packaging".

## Products Guide

### ●SMD Type (kHz)

Type	Applications	General Use											Attenuation (dB) min.
		AMPS	PDC	PAGER CORDLESS	TACS CORDLESS	AM	6dB Bandwidth (kHz) min.						
	A	B	C	D	E	F	G	H	J	K	L		
	±17.5	±15	±12.5	±10	±7.5	±6	±4.5	±3	±2	±1.5	±1		
High Selectivity Series (Plastic Case Type)	SFPKA455K□ (4 Elements)	-	-	-	●	●	●	●	●	-	-	-	27 (G to H ; 25)
	CFUKG455K□ (4 Elements)	-	-	-	●	●	●	●	●	-	-	-	27 (G ; 25)
Narrow Bandwidth GDT Flat Type Miniature Series (Plastic Case Type)	CFUKG455K□X (4 Elements)	-	-	-	●	●	●	●	●	-	-	-	27 (G to H ; 25)
GDT Flat Type Miniature Series (Plastic Case Type)	CFUKF455K□ (4 Elements)	●	●	●	●	●	-	-	-	-	-	-	25 (D to E ; 23)
GDT Flat Type High Selectivity SMD Series (Plastic Case Type)	CFWKA450KBFY (6 Elements)	-	●	-	-	-	-	-	-	-	-	-	45
High Selectivity SMD Series (Plastic Case Type)	CFWKA450K□ (6 Elements)	-	●	-	●	●	●	●	-	-	-	-	50

### ●Lead Type (kHz)

Type	Applications	General Use											Attenuation (dB) min.
		AMPS	PDC	PAGER CORDLESS	TACS CORDLESS	AM	6dB Bandwidth (kHz) min.						
	A	B	C	D	E	F	G	H	J	K	L		
	±17.5	±15	±12.5	±10	±7.5	±6	±4.5	±3	±2	±1.5	±1		
High Selectivity Low Profile Series	CFULA455K□ (4 Elements)	-	●	●	●	●	●	●	●	-	-	-	27 (G ; 25) (H, J ; 35)
	CFWLA455K□ (6 Elements)	-	●	●	●	●	●	●	●	●	-	-	35 (H, J ; 60)
High Selectivity Miniature Series	CFULB455K□ (4 Elements)	-	●	●	●	●	●	●	●	●	-	-	27 (G ; 25) (H, J ; 35)
	CFWL B455K□ (6 Elements)	-	●	●	●	●	●	●	●	●	-	-	35 (H, J ; 65)
GDT Flat Type Series	CFULA455K□Y (4 Elements)	-	●	●	●	●	●	●	-	-	-	-	25 (D to F ; 23) (G ; 20)
	CFWLA455K□Y (6 Elements)	●	●	●	●	●	●	●	-	-	-	-	35
GDT Flat Type Miniature Series	CFULB455K□Y (4 Elements)	-	●	●	●	●	●	●	-	-	-	-	25 (D to F ; 23) (G ; 20)
	CFWL B455K□Y (6 Elements)	●	●	●	●	●	●	●	-	-	-	-	35

# Ceramic Filters (CERAFIL®)/Ceramic Discriminators for Communications Equipment



1

## CERAFIL® kHz SMD Type SFPKA Series

The SFPKA series is comprised of small, high performance, economical, thin (5.0mm) filters consisting of 4 ceramic elements.

Their innovative construction is perfect for shrinking mobile communication products such as cordless phones, pagers and transceivers.

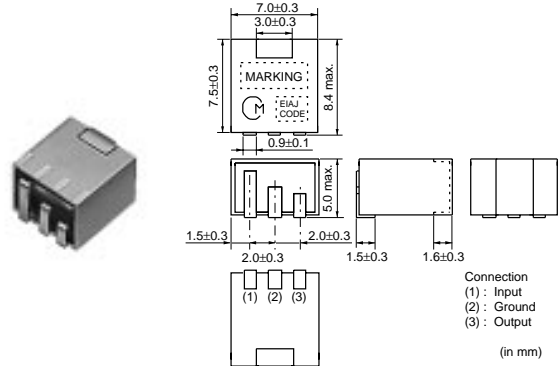

### ■ Features

1. The filters are mountable by automatic placers.
2. The filters can be reflow soldered and withstand washing.
3. They are slim, at only 5.0mm maximum thickness.
4. The bandwidth ranges from D to H.
5. Operating temperature range: -20 to +80 (degrees C)  
Storage temperature range: -40 to +85 (degrees C)

Part Number	Center Frequency (fo) (kHz)	6dB Bandwidth (kHz)	Stop Bandwidth (kHz)	Stop Band Attenuation (dB)	Insertion Loss (dB)	Ripple (dB)	Input/Output Impedance (ohm)
SFPKA455KD4A-R1	455 ±1.5kHz	fn±10.0 min.	fn±20.0 max. [within 40dB]	27 min. [within fn±100kHz]	4.0 max. [at minimum loss point]	2.0 max. [within fn±7kHz]	1500
SFPKA455KE4A-R1	455 ±1.5kHz	fn±7.5 min.	fn±15.0 max. [within 40dB]	27 min. [within fn±100kHz]	6.0 max. [at minimum loss point]	1.5 max. [within fn±5kHz]	1500
SFPKA455KF4A-R1	455 ±1.5kHz	fn±6.0 min.	fn±12.5 max. [within 40dB]	27 min. [within fn±100kHz]	6.0 max. [at minimum loss point]	1.5 max. [within fn±4kHz]	1500
SFPKA455KG1A-R1	455 ±1.0kHz	fn±4.5 min.	fn±10.0 max. [within 40dB]	25 min. [within fn±100kHz]	6.0 max. [at minimum loss point]	1.5 max. [within fn±3kHz]	1500
SFPKA455KH1A-R1	455 ±1.0kHz	fn±3.0 min.	fn±9.0 max. [within 40dB]	35 min. [within fn±100kHz]	6.0 max. [at minimum loss point]	1.5 max. [within fn±2kHz]	2000

Center frequency (fo) defined by the center of 6dB bandwidth.

(fn) means nominal center frequency 455kHz.

For safety purposes, connect the output of filters to the IF amplifier through a D.C. blocking capacitor. Avoid applying a direct current to the output of ceramic filters.

The order quantity should be an integral multiple of the "Minimum Quantity" shown in package page in this catalog.

### ■ Test Circuit

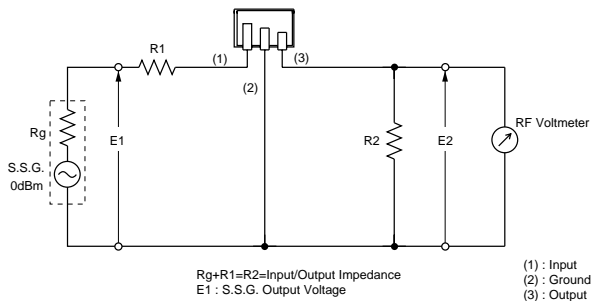

1

■ Frequency Characteristics

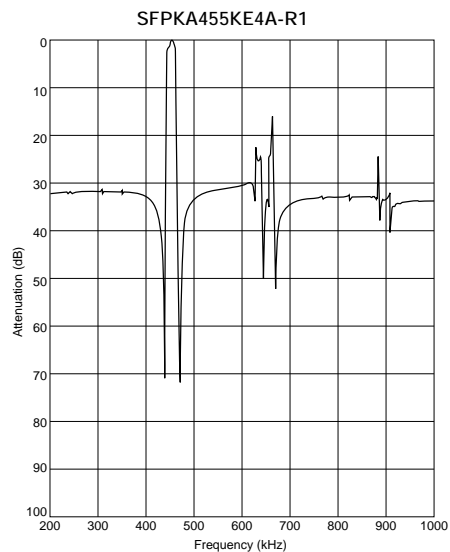
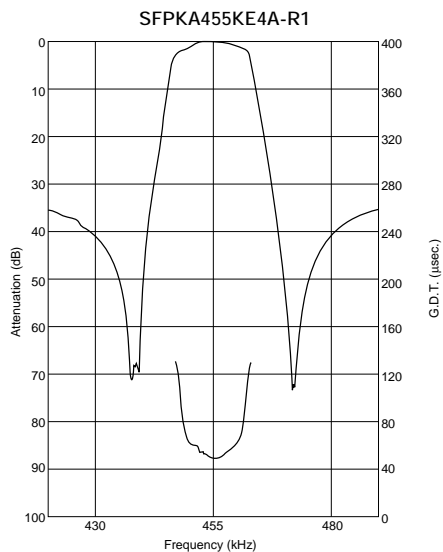



# Ceramic Filters (CERAFIL®)/Ceramic Discriminators for Communications Equipment



## CERAFIL® kHz SMD Type CFUKG Series

The CFUKG series is comprised of small, high performance, thin (4.0mm) filters consisting of 4 ceramic elements. Their innovative construction is perfect for shrinking mobile communication products such as pocket pagers and cellular phones.

### ■ Features

1. The filters are mountable by automatic placers.
2. The filters can be reflow soldered and withstand washing.
3. They are slim, at only 4.0mm maximum thickness, and have a small mounting area (7.5x6.0mm) enabling flexible PCB design.
4. The bandwidth ranges from D to G.
5. Operating temperature range: -20 to +80 (degrees C)  
Storage temperature range: -40 to +85 (degrees C)

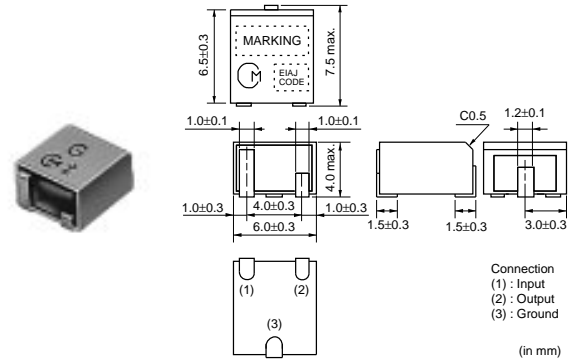

Part Number	Center Frequency (fo) (kHz)	6dB Bandwidth (kHz)	Stop Bandwidth (kHz)	Stop Band Attenuation (dB)	Insertion Loss (dB)	Ripple (dB)	Input/Output Impedance (ohm)
<b>CFUKG455KD4A-R0</b>	455 ±1.5kHz	fn±10.0 min.	fn±20.0 max. [within 40dB]	27 min. [within fn±100kHz]	4.0 max. [at minimum loss point]	2.0 max. [within fn±7kHz]	1500
<b>CFUKG455KE4A-R0</b>	455 ±1.5kHz	fn±7.5 min.	fn±15.0 max. [within 40dB]	27 min. [within fn±100kHz]	6.0 max. [at minimum loss point]	1.5 max. [within fn±5kHz]	1500
<b>CFUKG455KF4A-R0</b>	455 ±1.5kHz	fn±6.0 min.	fn±12.5 max. [within 40dB]	27 min. [within fn±100kHz]	6.0 max. [at minimum loss point]	1.5 max. [within fn±4kHz]	1500
<b>CFUKG455KG1A-R0</b>	455 ±1.0kHz	fn±4.5 min.	fn±10.0 max. [within 40dB]	25 min. [within fn±100kHz]	6.0 max. [at minimum loss point]	1.5 max. [within fn±3kHz]	1500

Center frequency (fo) defined by the center of 6dB bandwidth.

(fn) means nominal center frequency 455kHz.

For safety purposes, connect the output of filters to the IF amplifier through a D.C. blocking capacitor. Avoid applying a direct current to the output of ceramic filters.

The order quantity should be an integral multiple of the "Minimum Quantity" shown in package page in this catalog.

### ■ Test Circuit

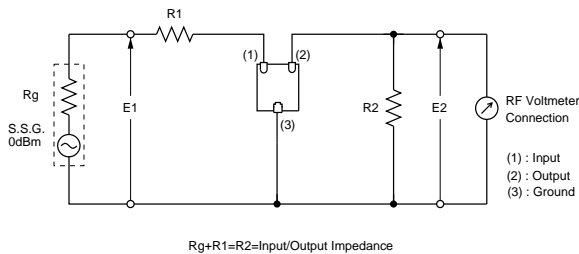

## Frequency Characteristics

2

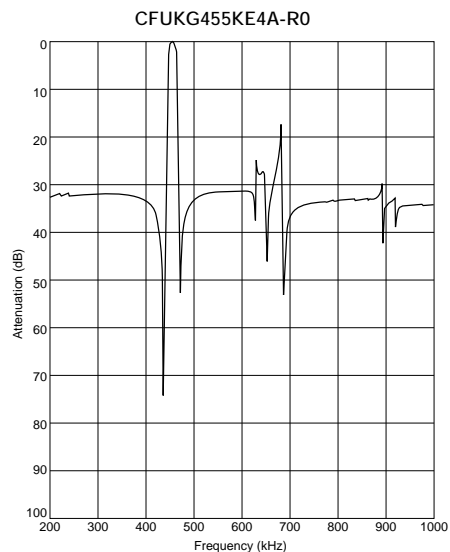
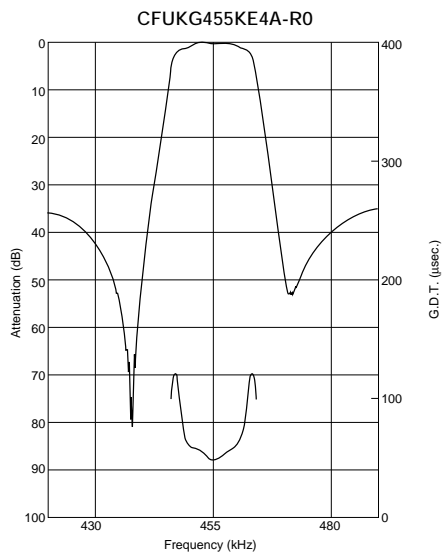

# Ceramic Filters (CERAFIL®)/Ceramic Discriminators for Communications Equipment



## CERAFIL® kHz SMD Type CFUKG\_X Series

The CFUKG\_X series is comprised of small, high performance, thin (4.0mm) filters consisting of 4 ceramic elements. The filters exhibit an extremely flat GDT characteristic combined with a narrow bandwidth. The filters are recommended for narrow band digital communication applications.

### ■ Features

1. The filters are mountable by automatic placers.
2. The filters can be reflow soldered and withstand washing.
3. They are slim, at only 4.0mm maximum thickness, and have a small mounting area (7.5x6.0mm) enabling flexible PCB design.
4. The bandwidth ranges from E to H.
5. Operating temperature range: -20 to +80 (degrees C)  
Storage temperature range: -40 to +85 (degrees C)

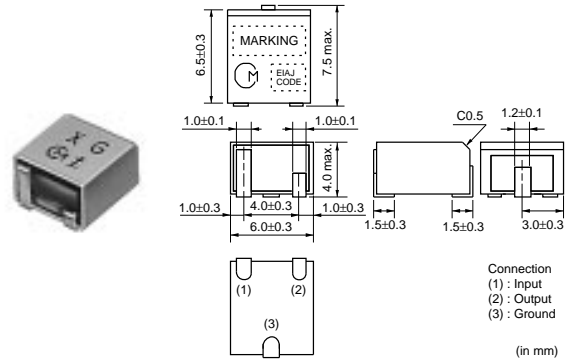

3

Part Number	Center Frequency (fo) (kHz)	6dB Bandwidth (kHz)	Stop Bandwidth (kHz)	Stop Band Attenuation (dB)	Insertion Loss (dB)	Ripple (dB)	GDT Deviation (μs)	Input/Output Impedance (ohm)
<b>CFUKG455KE4X-R0</b>	455 ±1.5kHz	fn±7.5 min.	fn±17.5 max. [within 40dB]	27 min. [within fn±100kHz]	6.0 max. [at minimum loss point]	1.0 max. [within fn±5kHz]	25.0 max. [within fn±5kHz]	1500
<b>CFUKG455KF4X-R0</b>	455 ±1.5kHz	fn±6.0 min.	fn±15.0 max. [within 40dB]	27 min. [within fn±100kHz]	6.0 max. [at minimum loss point]	1.0 max. [within fn±4kHz]	25.0 max. [within fn±4kHz]	1500
<b>CFUKG455KG1X-R0</b>	455 ±1.0kHz	fn±4.5 min.	fn±12.5 max. [within 40dB]	25 min. [within fn±100kHz]	6.0 max. [at minimum loss point]	1.0 max. [within fn±3kHz]	25.0 max. [within fn±3kHz]	1500
<b>CFUKG455KH1X-R0</b>	455 ±1.0kHz	fn±3.0 min.	fn±10.0 max. [within 40dB]	25 min. [within fn±100kHz]	7.0 max. [at minimum loss point]	1.0 max. [within fn±2kHz]	25.0 max. [within fn±2kHz]	1500

Center frequency (fo) defined by the center of 6dB bandwidth.  
(fn) means nominal center frequency 455kHz.

For safety purposes, connect the output of filters to the IF amplifier through a D.C. blocking capacitor. Avoid applying a direct current to the output of ceramic filters.  
The order quantity should be an integral multiple of the "Minimum Quantity" shown in package page in this catalog.

### ■ Test Circuit

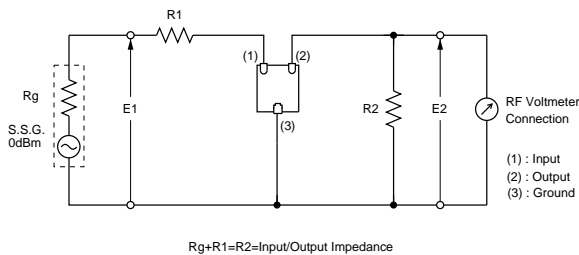

### ■ Frequency Characteristics

3

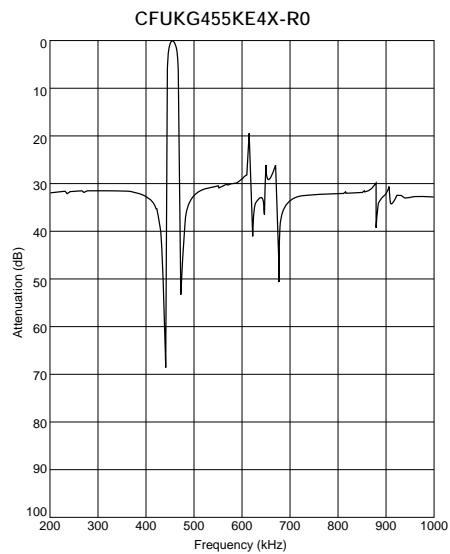
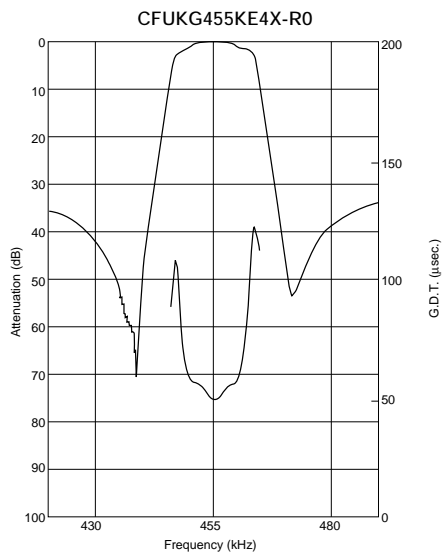

# Ceramic Filters (CERAFIL®)/Ceramic Discriminators for Communications Equipment



## CERAFIL® kHz SMD Type CFUKF Series

The CFUKF series is comprised of small, high performance, thin (4.0mm) filters consisting of 4 ceramic elements. The filters exhibit an extremely flat GDT characteristic. The filters are recommended for digital communication applications and are perfect in hand held cellular phones, etc.

### ■ Features

1. The filters are mountable by automatic placers.
2. The filters can be reflow soldered and withstand washing.
3. They are slim, at only 4.0mm maximum thickness, and have a small mounting area (7.5x6.0mm) enabling flexible PCB design.
4. The bandwidth ranges from A to E.
5. Operating temperature range: -20 to +80 (degrees C)  
Storage temperature range: -40 to +85 (degrees C)

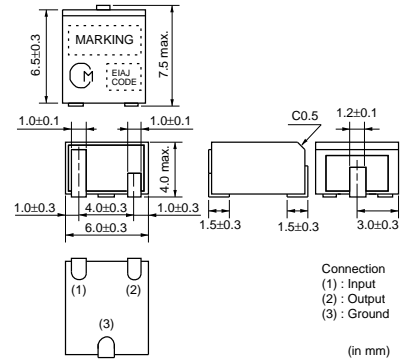

4

Part Number	Center Frequency (fo) (kHz)	6dB Bandwidth (kHz)	Stop Bandwidth (kHz)	Stop Band Attenuation (dB)	Insertion Loss (dB)	Ripple (dB)	GDT Deviation (μs)	Input/Output Impedance (ohm)
CFUKF455KA2X-R0	455 ±2.0kHz	fn±17.5 min.	fn±40.0 max. [within 40dB]	25 min. [within fn±100kHz]	4.0 max. [at minimum loss point]	1.0 max. [within fn±12kHz]	15.0 max. [within fn±12kHz]	1000
CFUKF455KB4X-R0	455 ±1.5kHz	fn±15.0 min.	fn±35.0 max. [within 40dB]	25 min. [within fn±100kHz]	5.0 max. [at minimum loss point]	1.0 max. [within fn±10kHz]	15.0 max. [within fn±10kHz]	1000
CFUKF455KC4X-R0	455 ±1.5kHz	fn±12.5 min.	fn±30.0 max. [within 40dB]	25 min. [within fn±100kHz]	6.0 max. [at minimum loss point]	1.0 max. [within fn±8kHz]	15.0 max. [within fn±8kHz]	1000
CFUKF455KD1X-R0	455 ±1.0kHz	fn±10.0 min.	fn±25.0 max. [within 40dB]	23 min. [within fn±100kHz]	7.0 max. [at minimum loss point]	1.0 max. [within fn±7kHz]	20.0 max. [within fn±7kHz]	1500
CFUKF455KE1X-R0	455 ±1.0kHz	fn±7.5 min.	fn±20.0 max. [within 40dB]	23 min. [within fn±100kHz]	8.0 max. [at minimum loss point]	1.0 max. [within fn±5kHz]	20.0 max. [within fn±5kHz]	1500

Center frequency (fo) defined by the center of 6dB bandwidth.

(fn) means nominal center frequency 455kHz.

For safety purposes, connect the output of filters to the IF amplifier through a D.C. blocking capacitor. Avoid applying a direct current to the output of ceramic filters.

The order quantity should be an integral multiple of the "Minimum Quantity" shown in package page in this catalog.

### ■ Test Circuit

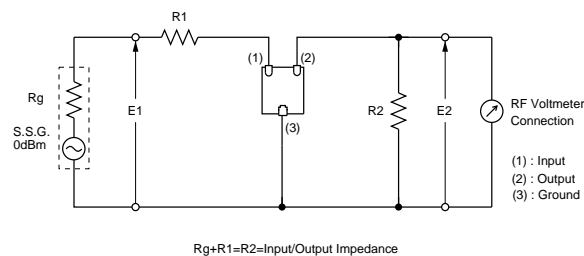

## Frequency Characteristics

CFUKF455KE1X-R0

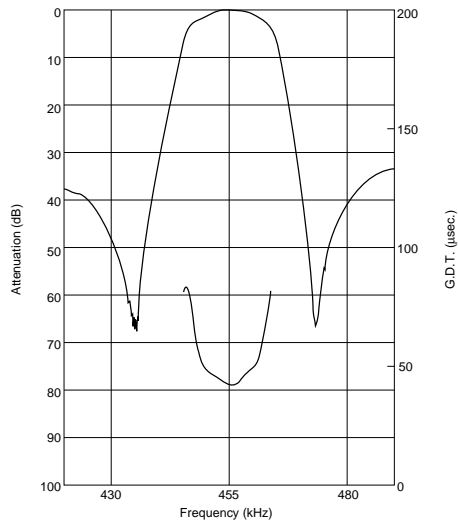

CFUKF455KE1X-R0

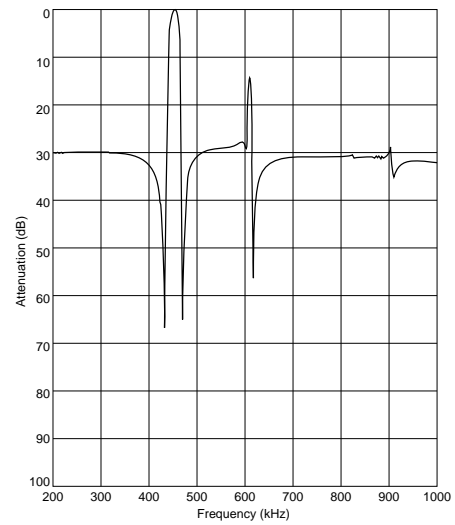

4

# Ceramic Filters (CERAFIL®)/Ceramic Discriminators for Communications Equipment



## CERAFIL® kHz SMD Type CFWKA Series

The CFWKA series is comprised of small, high performance, thin (3.0mm) filters consisting of 6 ceramic elements. The filters are recommend for pager or hand held cellular phones.

### ■ Features

1. The filters are mountable by automatic placers.
2. The filters can be reflow soldered.
3. They are slim, at only 3.0mm maximum thickness.
4. The filters are wide bandwidth, flat GDT within pass band.
5. Operating temperature range: -20 to +80 (degrees C)  
Storage temperature range: -40 to +85 (degrees C)

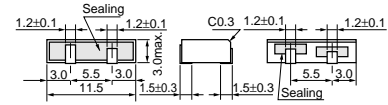
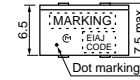

(1): Input  
(2): Output  
(3)(4): Ground  
(Tolerance ±0.3mm in mm)

Part Number	Nominal Center Frequency (fn) (kHz)	3dB Bandwidth (kHz)	6dB Bandwidth (kHz)	Stop Bandwidth (kHz)	Stop Band Attenuation (dB)	Stop Band Att.(2) (dB)	Insertion Loss (dB)	Ripple (dB)	Input/Output Impedance (ohm)
<b>CFWKA450K DFA-R0</b>	450.0	-	fn±10.0 min.	fn±20.0 max. [within 50dB]	50 min. [within fn±100kHz]	-	4.0 max. [at minimum loss point]	3.0 max. [within fn±7kHz]	1500
<b>CFWKA450KEFA-R0</b>	450.0	-	fn±7.5 min.	fn±15.0 max. [within 50dB]	50 min. [within fn±100kHz]	-	6.0 max. [at minimum loss point]	3.0 max. [within fn±5kHz]	1500
<b>CFWKA450KEFA001-R0</b>	450.0	fn±6.5 min.	-	fn±15.0 max. [within 50dB]	55 min. [fn±18 to ±33kHz]	50 min. [within fn±100kHz]	4.0 max. [at fn]	3.0 max. [within fn±6.5kHz]	1500
<b>CFWKA450KFFA-R0</b>	450.0	-	fn±6.0 min.	fn±12.5 min. [within 50dB]	50 min. [within fn±100kHz]	-	6.0 max. [at minimum loss point]	3.0 max. [within fn±4kHz]	1500
<b>CFWKA450KGFA-R0</b>	450.0	-	fn±4.5 min.	fn±11.0 max. [within 50dB]	50 min. [within fn±100kHz]	-	6.0 max. [at minimum loss point]	2.0 max. [within fn±3kHz]	1500

For safety purposes, connect the output of filters to the IF amplifier through a D.C. blocking capacitor. Avoid applying a direct current to the output of ceramic filters. The order quantity should be an integral multiple of the "Minimum Quantity" shown in package page in this catalog.

### ■ Test Circuit

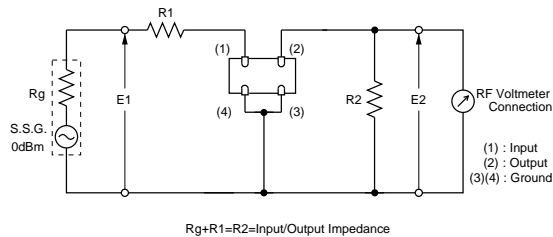

## ■ Frequency Characteristics

CFWKA450KEFA001-R0

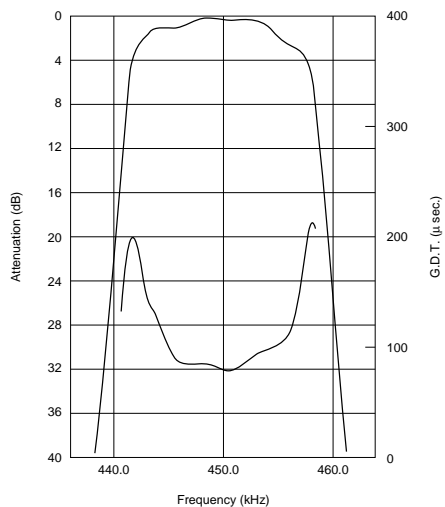

CFWKA450KEFA001-R0

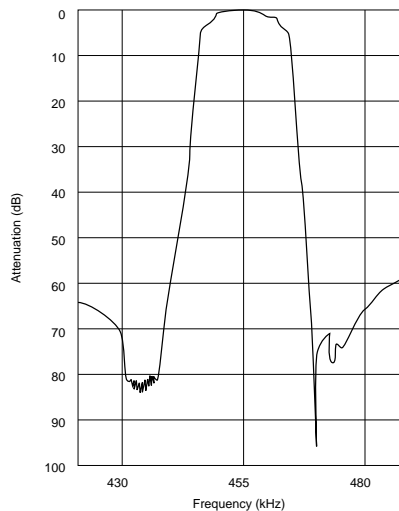

CFWKA450KEFA001-R0

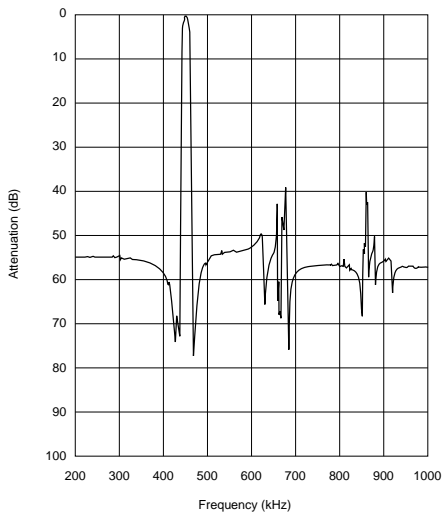

5



# Ceramic Filters (CERAFIL®)/Ceramic Discriminators for Communications Equipment



## CERAFIL® kHz SMD Type CFWKA\_Y Series

The CFWKA\_Y series is comprised of small, high performance, thin (3.0mm) filters consisting of 6 ceramic elements. The filters are recommend for digital communication applications and are perfect in hand held cellular phones.

### ■ Features

1. The filters are mountable by automatic placers, and can be reflow soldered.
2. They are slim, at only 3.0mm maximum thickness.
3. The filters are wide bandwidth, flat GDT within pass band.
4. Operating temperature range: -20 to +80 (degrees C)  
Storage temperature range: -40 to +85 (degrees C)

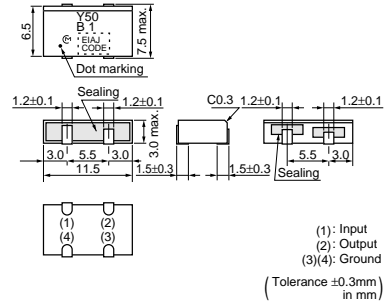

Part Number	Nominal Center Frequency (f <sub>n</sub> ) (kHz)	3dB Bandwidth (kHz)	6dB Bandwidth (kHz)	Stop Bandwidth (kHz)	Stop Band Attenuation (dB)	Insertion Loss (dB)	Spurious Response (dB)	GDT Deviation (μs)	Input/Output Impedance (ohm)
<b>CFWKA450KBFY001-R0</b>	450.0	f <sub>n</sub> ±11.5 min.	f <sub>n</sub> ±13.0 min.	f <sub>n</sub> ±30.0 max. [within 50dB]	45 min. [within f <sub>n</sub> ±100kHz]	4.0 max. [at minimum loss point]	20 min. [within 0.1 to 1.0MHz]	30.0 max. [within f <sub>n</sub> ±10kHz]	1000

For safety purposes, connect the output of filters to the IF amplifier through a D.C. blocking capacitor. Avoid applying a direct current to the output of ceramic filters. The order quantity should be an integral multiple of the "Minimum Quantity" shown in package page in this catalog.

### ■ Test Circuit

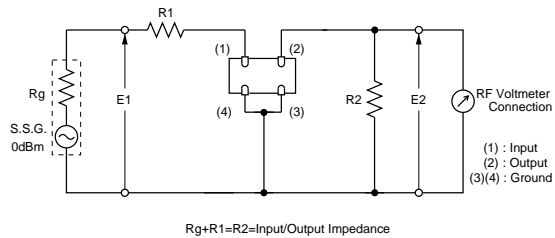

## Frequency Characteristics

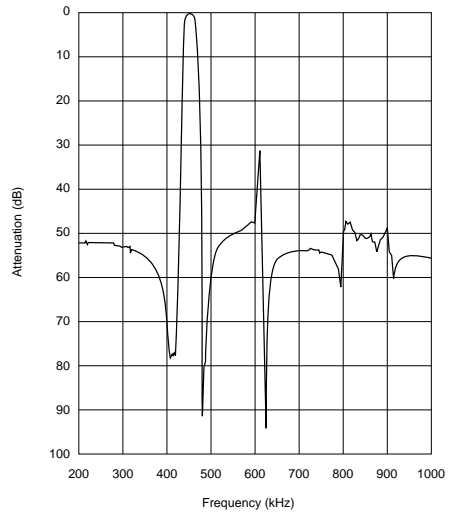
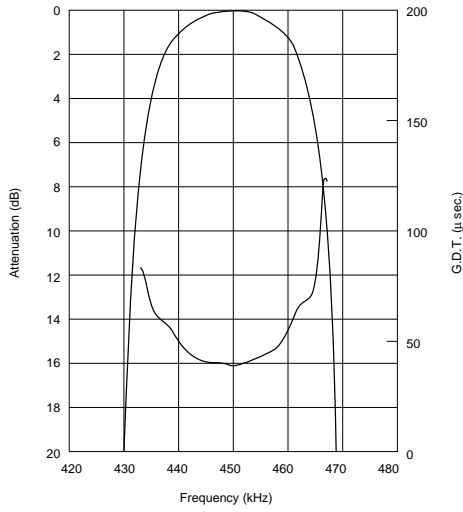

6

## kHz SMD Type CERAFIL® Notice

### ■ SFPKA/CFUKG/CFUKF Series Notice (Soldering and Mounting)

#### 1. Standard Reflow Soldering Conditions

##### (1) Reflow

Filter is soldered twice within the following temperature conditions.

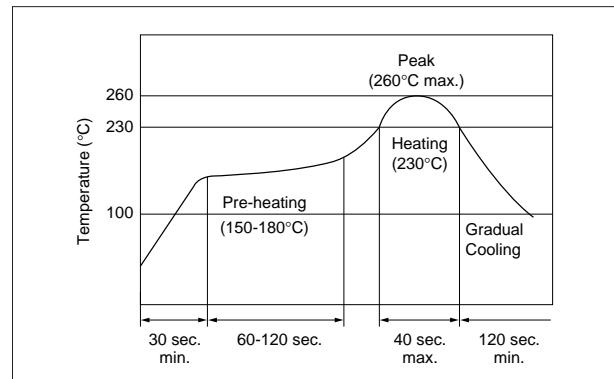

##### (2) Soldering Iron

Electrode is directly soldered with the tip of soldering iron at  $+350\pm 5^{\circ}\text{C}$  for  $3.0\pm 0.5$  seconds.

#### 2. Wash

##### (1) Cleaning Solvent

CFC alternatives (HCFC Series), Isopropyl Alcohol (IPA), Water (Demineralized Water), Cleaning Water Solution (Cleanthrough-750H, Pine Alpha 100S), Silicon (Technocare FRW)

##### (2) Cleaning Conditions

- Immersion Wash  
2 minutes max. in above solvent at  $+60^{\circ}\text{C}$  max.
- Shower or Rinse Wash  
2 minutes max. in above solvent at  $+60^{\circ}\text{C}$  max.

##### (3) Notice

- When components are immersed in solvent, be sure to maintain the temperature of components below the temperature of solvent.
- Please do not use ultrasonic cleaning.
- Total washing time should be within 4 minutes.
- Please ensure the component is thoroughly evaluated in your application circuit.
- Please do not use chlorine, petroleum and alkaline cleaning solvents.
- If you plan to use any other type of solvents, please consult with Murata or Murata representative prior to using.

Continued on the following page. 

## kHz SMD Type CERAFIL® Notice

☒ Continued from the preceding page.

### ■ CFWKA Series Notice (Soldering and Mounting)

#### 1. Standard Reflow Soldering Conditions

##### (1) Reflow

Filter is soldered twice within the following temperature conditions.

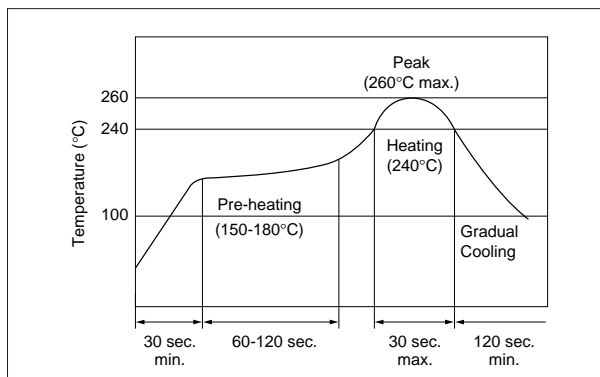

##### (2) Soldering Iron

Electrode is directly soldered with the tip of soldering iron at  $+350\pm 5^{\circ}\text{C}$  for  $3.0\pm 0.5$  seconds.

#### 2. Wash

The component cannot withstand washing.

### ■ CFWKA Series Notice (Handling)

1. The component will be damaged when an excessive stress is applied.
2. For safety purposes, connect the output of filters to the IF amplifier through a D.C. blocking capacitor. Avoid applying a direct current to the output of ceramic filters.
3. Do not clean or wash the component as it's not hermetically sealed.
4. Do not apply conformal coating onto the component as it's not hermetically sealed.
5. Do not use strong acidity flux, more than 0.2wt% chlorine content, in re-flow soldering.

### ■ SFPKA/CFUKG/CFUKF Series Notice (Handling)

1. The component will be damaged when an excessive stress is applied.
2. In the case that the component is cleaned, confirm that no reliability degradation is created.
3. In case of covering filter with over coat, conditions such as material of resin, cure temperature, and so on should be evaluated carefully.
4. Do not use strong acidity flux, more than 0.2wt% chlorine content, in re-flow soldering.
5. The product, packed in the moisture-proof bag (dry pack), is sensitive to moisture. The following treatment is required before applying re-flow soldering, to avoid package cracks or reliability degradation caused by thermal stress. When unpacked, store the component in an atmosphere of below 25 degree C and below 65%R.H., and solder within 48 hours.
6. For safety purposes, connect the output of filters to the IF amplifier through a D.C. blocking capacitor. Avoid applying a direct current to the output of ceramic filters.

# Ceramic Filters (CERAFIL®)/Ceramic Discriminators for Communications Equipment



## CERAFIL® MHz SMD Type SFECF10M7 Series

SFECF10M7 series for FM-receivers are small, high performance and super thin (1.4mm max.) filters. Piezoelectric element is connected in the sandwich shape by ceramics substrate. They have 1.4mm max. thickness and small mounting area. (3.45x3.1mm)  
 SFECF series and CDSCB series (MHz Discriminator) enable customers to make VICS/RKE/TPMS set so thin and small sized.

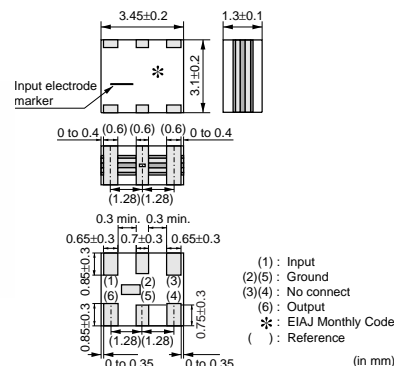

### ■ Features

1. The filters are mountable by automatic placers.
2. They are slim, at only 1.4mm max. thickness, and have a small mounting area (3.45x3.1mm) enabling flexible PCB design.
3. Various bandwidths are available. Select a suitable type in accordance with the desired selectivity.
4. Operating temperature range: -20 to +80 (degrees C)  
Storage temperature range: -40 to +85 (degrees C)

### Standard Type

Part Number	Center Frequency (fo) (MHz)	Nominal Center Frequency (fn) (MHz)	3dB Bandwidth (kHz)	Attenuation (kHz)	Insertion Loss (dB)	Ripple (dB)	Spurious Attenuation (1) (dB)	Input/Output Impedance (ohm)	Spurious Attenuation (2) (dB)
SFECF10M7HA00-R0	10.700 ±30kHz	-	180 ±40kHz	470 max.	4.0 ±2.0dB	1.0 max.	30 min.	330	-
SFECF10M7HF00-R0	-	10.700	fn±25 min.	510 max.	8.0 max. [at fn]	1.0 max.	30 min. [within 9MHz to fn]	330	25 min. [within fn to 12MHz]
SFECF10M7GA00-R0	10.700 ±30kHz	-	230 ±50kHz	510 max.	3.5 ±2.0dB	1.0 max.	30 min.	330	-
SFECF10M7GF00-R0	-	10.700	fn±45 min.	560 max.	8.0 max. [at fn]	1.0 max.	30 min. [within 9MHz to fn]	330	25 min. [within fn to 12MHz]
SFECF10M7FA00-R0	10.700 ±30kHz	-	280 ±50kHz	590 max.	3.0 ±2.0dB	1.0 max.	30 min.	330	-
SFECF10M7FF00-R0	-	10.700	fn±65 min.	620 max.	7.0 max. [at fn]	1.0 max.	30 min. [within 9MHz to fn]	330	25 min. [within fn to 12MHz]
SFECF10M7EA00-R0	10.700 ±30kHz	-	330 ±50kHz	700 max.	3.0 ±2.0dB	1.0 max.	30 min.	330	-
SFECF10M7DA0001-R0	10.700 ±30kHz	-	420 min.	950 max.	3.0 ±2.0dB	3.0 max.	35 min. [within 9MHz to fo]	330	25 min. [within fo to 12MHz]
SFECF10M7DF00-R0	-	10.700	fn±150 min.	990 max.	6.0 max. [at fn]	3.0 max.	20 min.	330	-
SFECF10M7CQ00-R0	10.700 ±30kHz	-	500 ±50kHz	950 max.	2.0 +2.0/-1.0dB	3.0 max.	30 min. [within 9MHz to fo]	470	25 min. [within fo to 12MHz]

Area of Attenuation: [within 20dB] Area of Spurious Attenuation: [within 9MHz to 12MHz]

Area of Insertion Loss: at minimum loss point Area of Ripple: within 3dB B.W.

Center frequency (fo) defined by center of 3dB bandwidth.

For safety purposes, connect the output of filters to the IF amplifier through a D.C. blocking capacitor. Avoid applying a direct current to the output of ceramic filters.

The order quantity should be an integral multiple of the "Minimum Quantity" shown in package page in this catalog.

## High-reliability Type

Part Number	Center Frequency (fo) (MHz)	Nominal Center Frequency (fn) (MHz)	3dB Bandwidth (kHz)	Attenuation (kHz)	Insertion Loss (dB)	Ripple (dB)	Spurious Attenuation (1) (dB)	Input/Output Impedance (ohm)	Spurious Attenuation (2) (dB)
SFECF10M7HA00S0-R0	10.700 ±30kHz	-	180 ±40kHz	470 max.	4.0 ±2.0dB	1.0 max.	30 min.	330	-
SFECF10M7HF00S0-R0	-	10.700	fn±25 min.	510 max.	8.0 max. [at fn]	1.0 max.	30 min. [within 9MHz to fn]	330	25 min. [within fn to 12MHz]
SFECF10M7GA00S0-R0	10.700 ±30kHz	-	230 ±50kHz	510 max.	3.5 ±2.0dB	1.0 max.	30 min.	330	-
SFECF10M7GF00S0-R0	-	10.700	fn±45 min.	560 max.	8.0 max. [at fn]	1.0 max.	30 min. [within 9MHz to fn]	330	25 min. [within fn to 12MHz]
SFECF10M7FA00S0-R0	10.700 ±30kHz	-	280 ±50kHz	590 max.	3.0 ±2.0dB	1.0 max.	30 min.	330	-
SFECF10M7FF00S0-R0	-	10.700	fn±65 min.	630 max.	7.0 max. [at fn]	1.0 max.	30 min. [within 9MHz to fn]	330	25 min. [within fn to 12MHz]
SFECF10M7EA00S0-R0	10.700 ±30kHz	-	330 ±50kHz	700 max.	3.0 ±2.0dB	1.0 max.	30 min.	330	-
SFECF10M7DF00S0-R0	-	10.700	fn±145 min.	990 max.	6.0 max. [at fn]	3.0 max.	20 min.	330	-
SFECF10M7CQ00S0-R0	10.700 ±30kHz	-	500 ±50kHz	950 max.	2.0 +2.0/-1.0dB	3.0 max.	30 min. [within 9MHz to fo]	470	25 min. [within fo to 12MHz]

Area of Attenuation: [within 20dB] Area of Spurious Attenuation: [within 9MHz to 12MHz]

Area of Insertion Loss: at minimum loss point Area of Ripple: within 3dB B.W.

Center frequency (fo) defined by center of 3dB bandwidth.

For safety purposes, connect the output of filters to the IF amplifier through a D.C. blocking capacitor. Avoid applying a direct current to the output of ceramic filters.

The order quantity should be an integral multiple of the "Minimum Quantity" shown in package page in this catalog.

7

### Test Circuit

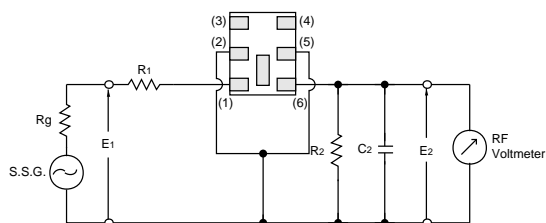

Rg = 50Ω R1 = 280Ω ±5% R2 = 330Ω ±5%  
 C2 = 10 ± 2 pF (Including stray capacitance and Input capacitance of RF Volt Meter)

E1 : S.S.G. Output Voltage

(1) : Input  
 (2)(5) : Ground  
 (3)(4) : No connect  
 (6) : Output

### Frequency Characteristics

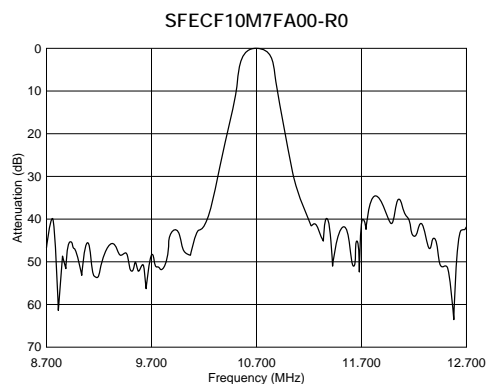
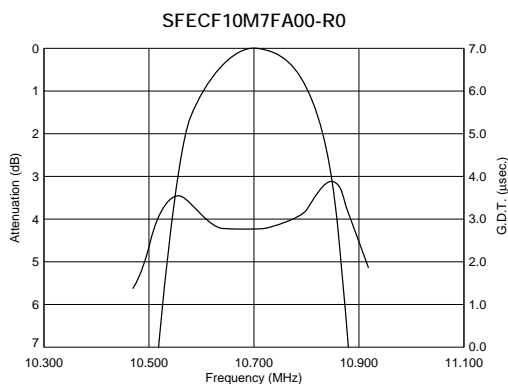

# Ceramic Filters (CERAFIL®)/Ceramic Discriminators for Communications Equipment



## CERAFIL® MHz SMD Type SFSCE10M7 Series

SFSCE series are chip surface mount filter and available for 3dB bandwidth at 700kHz to 1.3MHz. (more than twice width compared with current types) They have 1.0mm max. thickness and small mounting area. (4.5x3.8mm)

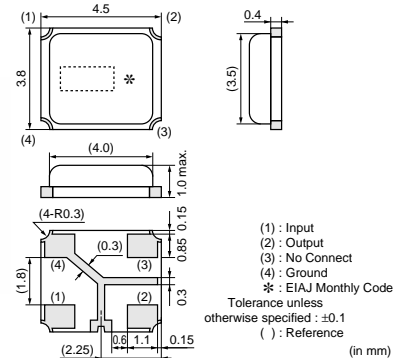

### ■ Features

1. The filters are mountable by automatic placers.
2. They are slim, at only 1.0mm max. thickness, and have a small mounting area (4.5x3.8mm) enabling flexible PCB design.
3. Available lead (Pb) free solder reflow.
4. Operating temperature range:  
 -20 to +80 (degrees C)  
 Storage temperature range:  
 -40 to +85 (degrees C)

### ■ Applications

1. SS digital communication system
2. Digital wireless audio
3. PHS Evolution system
4. RFID Reader Writer
5. RKE

Part Number	Nominal Center Frequency (fn) (MHz)	3dB Bandwidth (kHz)	Stop Bandwidth (MHz)	Insertion Loss (dB)	Ripple (dB)	Spurious Response (dB)	GDT Deviation (μs)	Input/Output Impedance (ohm)
<b>SFSCE10M7WF03-R0</b>	10.700	fn±500.0 min.	2.2 max. (Total) [within 20dB]	6.0 max. [at minimum loss point]	2.0 max. [within 3dB Bandwidth]	30/25 min. [within 5.7MHz to fn / fn to 15.7MHz]	0.6 max. [within fn±400kHz]	470
<b>SFSCE10M7WF04-R0</b>	10.700	fn±400.0 min.	1.8 max. (Total) [within 20dB]	6.0 max. [at minimum loss point]	1.5 max. [within 3dB Bandwidth]	35/25 min. [within 5.7MHz to fn / fn to 15.7MHz]	0.6 max. [within fn±325kHz]	470
<b>SFSCE10M7WF05-R0</b>	10.700	fn±325.0 min.	1.7 max. (Total) [within 20dB]	6.0 max. [at minimum loss point]	1.5 max. [within 3dB Bandwidth]	40/30 min. [within 5.7MHz to fn / fn to 15.7MHz]	0.6 max. [within fn±250kHz]	470

For safety purposes, connect the output of filters to the IF amplifier through a D.C. blocking capacitor. Avoid applying a direct current to the output of ceramic filters. The order quantity should be an integral multiple of the "Minimum Quantity" shown in package page in this catalog.

### ■ Test Circuit

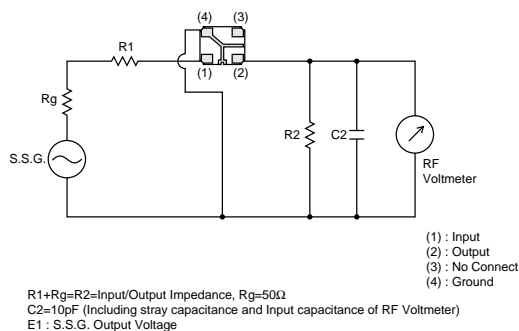

## ■ Frequency Characteristics

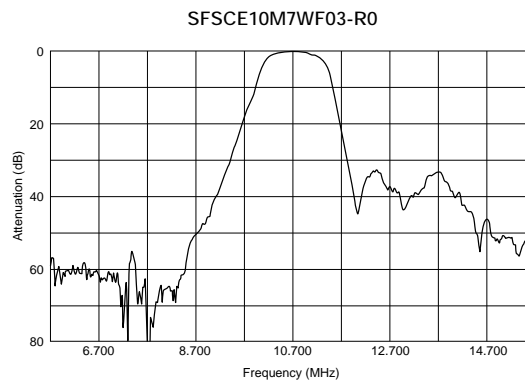
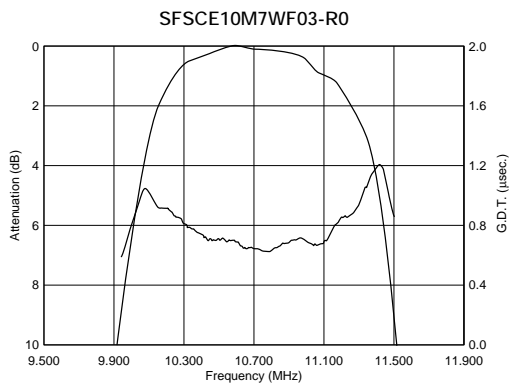



## MHz SMD Type CERAFIL® Notice

### ■ SFECF10M7 Series Notice (Soldering and Mounting)

#### 1. Standard Reflow Soldering Conditions

##### (1) Reflow

Filter is soldered twice within the following temperature conditions.

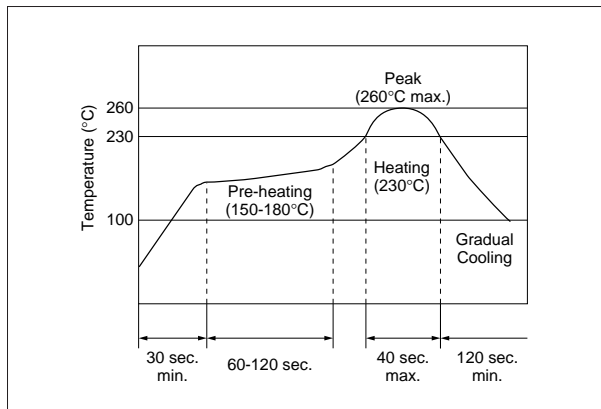

##### (2) Soldering Iron

Filter is soldered at  $+350\pm 5^{\circ}\text{C}$  for  $3.0\pm 0.5$  seconds. The soldering iron should not touch the filter while soldering.

#### 2. Wash

The component cannot withstand washing.

### ■ SFSCE10M7WF03-R0 Notice (Soldering and Mounting)

#### 1. Standard Reflow Soldering Conditions

##### (1) Reflow

Filter is soldered twice within the following temperature conditions.

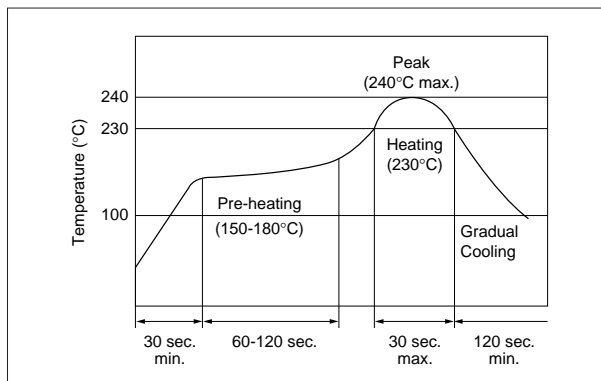

##### (2) Soldering Iron

Filter is soldered at  $+320\pm 5^{\circ}\text{C}$  for  $3.0\pm 0.5$  seconds. The soldering iron should not touch the filter while soldering.

#### 2. Wash

The component cannot withstand washing.

Continued on the following page.

## MHz SMD Type CERAFIL<sup>®</sup> Notice

☒ Continued from the preceding page.

### ■ SFSCE10M7WF04/05-R0 Notice (Soldering and Mounting)

#### 1. Standard Reflow Soldering Conditions

##### (1) Reflow

Filter is soldered twice within the following temperature conditions.

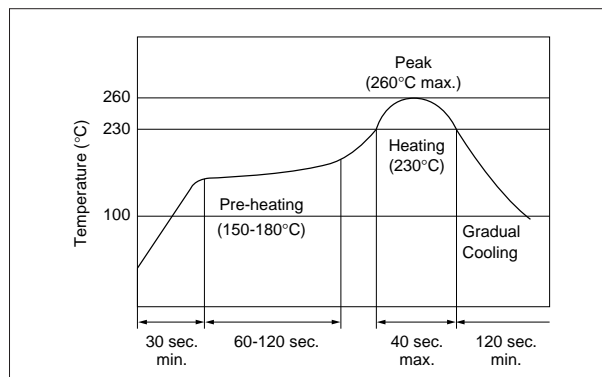

##### (2) Soldering Iron

Filter is soldered at  $+320\pm 5^{\circ}\text{C}$  for  $3.0\pm 0.5$  seconds. The soldering iron should not touch the filter while soldering.

#### 2. Wash

The component cannot withstand washing.

Continued on the following page. ☒

## MHz SMD Type CERAFIL<sup>®</sup> Notice

Continued from the preceding page.

### ■ SFECF10M7 Series Notice (Handling)

1. The component will be damaged when an excessive stress is applied.
2. The component may be damaged if excess mechanical stress is applied to it mounted on the printed circuit board.
3. Design layout of components on the PC board to minimize the stress imposed on the warp or flexure of the board.
4. After installing chips, if solder is excessively applied to the circuit board, mechanical stress will cause destruction resistance characteristics to lower. To prevent this, be extremely careful in determining shape and dimension before designing the circuit board diagram.
5. The component may be damaged during mounting process if some part of mounter such as positioning claws or nozzle are worn down. The regular maintenance recommended for mounters should be done to prevent trouble.
6. The component is recommended with placement machines which employ optical placement capabilities. The component might be damaged by excessive mechanical force. Please make sure that you have evaluated by using placement machines before going into mass production. Do not use placement machines which utilize mechanical positioning. Please contact Murata for details beforehand.
7. When correcting chips with a soldering iron, the tip of the soldering iron should not directly touch the chip component. Depending on the soldering conditions, the effective area of terminations may be reduced. The use of solder containing Ag should be done to prevent the electrode erosion.
8. Do not clean or wash the component as it is not hermetically sealed.
9. In case of covering filter with over coat, conditions such as material of resin, cure temperature, and so on should be evaluated carefully.
10. Do not use strong acidity flux, more than 0.2wt% chlorine content, in re-flow soldering.
11. Accurate test circuit values are required to measure electrical characteristics.  
It may be a cause of miscorrelation if there is any deviation, especially stray capacitance, from the test circuit in the specification.
12. The components, packed in the moisture proof bag (dry pack), are sensitive to moisture. The following treatment is required before applying re-flow soldering. To avoid reliability degradation caused by thermal stress, when unpacked, store the component in an atmosphere at 30°C and below 60%R.H., and solder within 1 week.
13. For safety purposes, connect the output of filters to the IF amplifier through a D.C. blocking capacitor. Avoid applying a direct current to the output of ceramic filters.

[Component layout close to board]

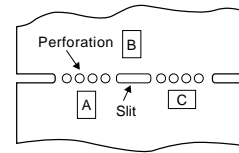

Susceptibility to stress is in the order of : A>C>B

Continued on the following page. 

## MHz SMD Type CERAFIL® Notice

☒ Continued from the preceding page.

### ■ SFSC10M7 Series Notice (Handling)

1. The component will be damaged when an excessive stress is applied.
2. The component mounted on the PCB may be damaged if excess mechanical stress is applied.
3. Layout the components on the PCB to minimize the stress imposed on the warp or flexure of the board.
4. After installing chips, if solder is excessively applied to the circuit board, mechanical stress will cause destruction resistance characteristics to lower. To prevent this, be extremely careful in determining shape and dimension before designing the circuit board diagram.
5. The component may be damaged during mounting process if some part of moulder such as positioning claws, nozzle are worn down. The regular maintenance recommended for moulter should be done to prevent the trouble.
6. When correcting component's position with a soldering iron, the tip of the soldering iron should not directly touch the chip component.
7. Do not clean or wash the component as it is not hermetically sealed.
8. In case of overcoating the part, coating conditions such as material of resin, curing temperature, and so on should be evaluated carefully.
9. Do not use strong acidity flux, more than 0.2wt% chlorine content, in re-flow soldering.
10. Accurate test circuit values are required to measure electrical characteristics. It may be a cause of mis-correlation if there is any deviation, especially stray capacitance, from the test circuit in the specification.
11. The component is recommended with placement machines which employ optical placement capabilities. The component might be damaged by excessive mechanical force. Please make sure that you have evaluated by using placement machines before going into mass production. Do not use placement machines which utilize mechanical positioning. Please contact Murata for details beforehand.
12. For safety purposes, connect the output of filters to the IF amplifier through a D.C. blocking capacitor. Avoid applying a direct current to the output of ceramic filters.

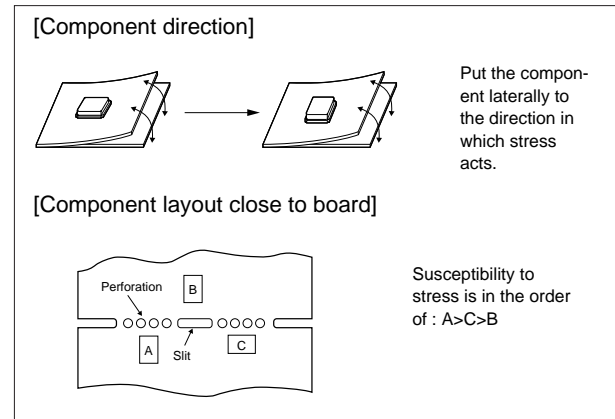

# SMD Type CERAFIL® Standard Land Pattern Dimensions

## ■ SFPKA Series

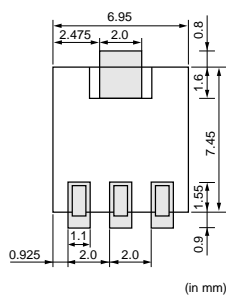

## ■ CFUKG/CFUKF Series

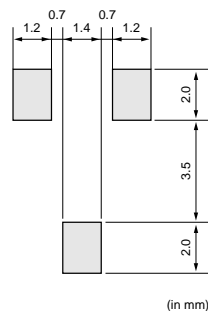

## ■ CFWKA Series

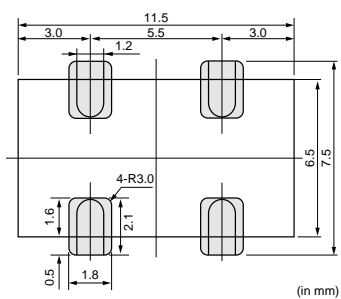

## ■ SFECF10M7 Series

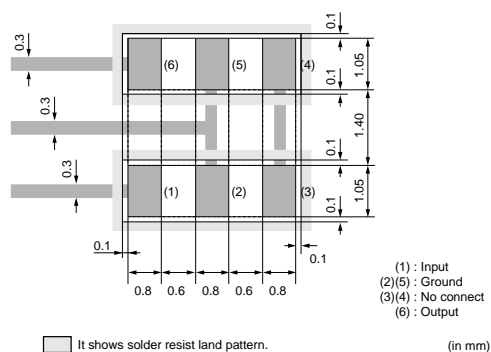

## kHz SMD Type CERAFIL® Packaging

### Minimum Quantity

Part Number	ø180mm	ø330mm
SFPKA		1,000
CFUKG	450	
CFUKF	450	
CFWKA	350	

### SFPKA Series

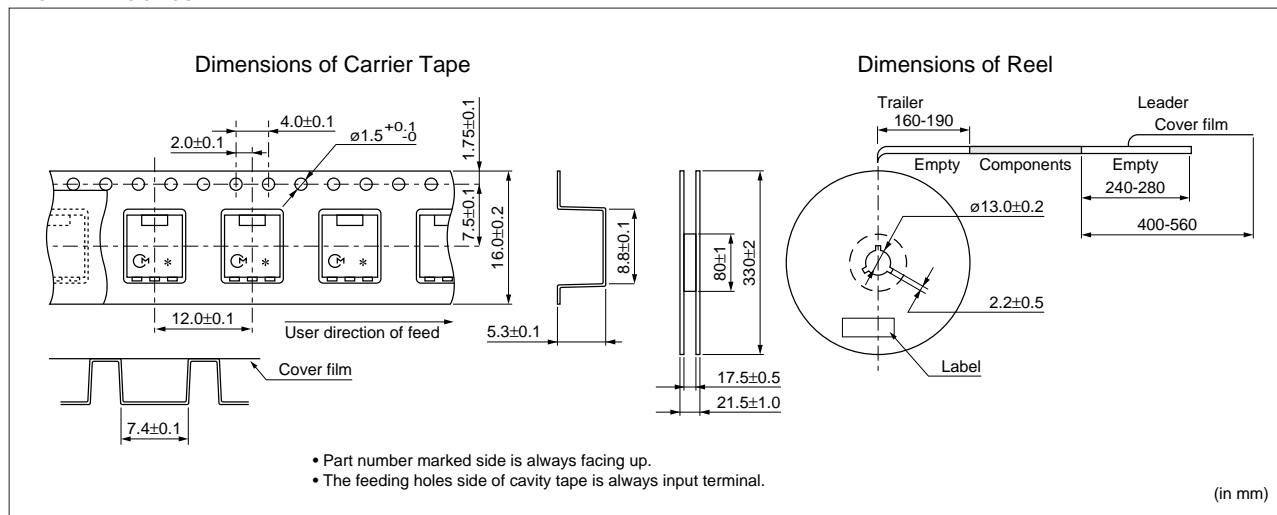

### CFUKG/CFUKF Series

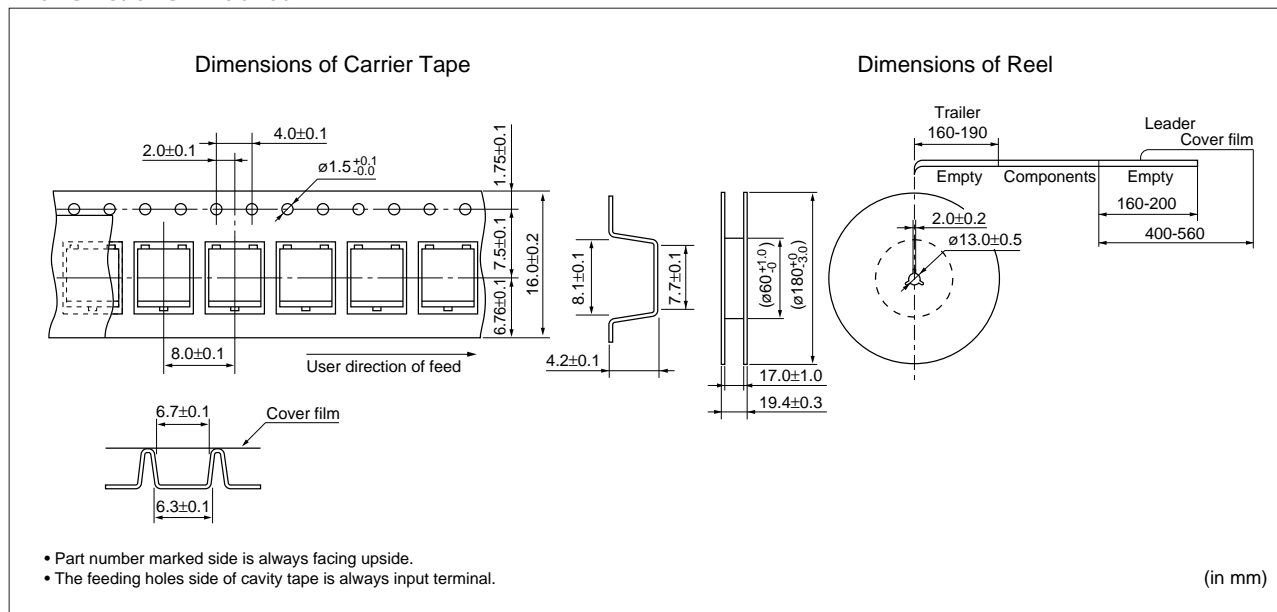

Continued on the following page. ↗

## kHz SMD Type CERAFIL® Packaging

Continued from the preceding page.

### CFWKA Series

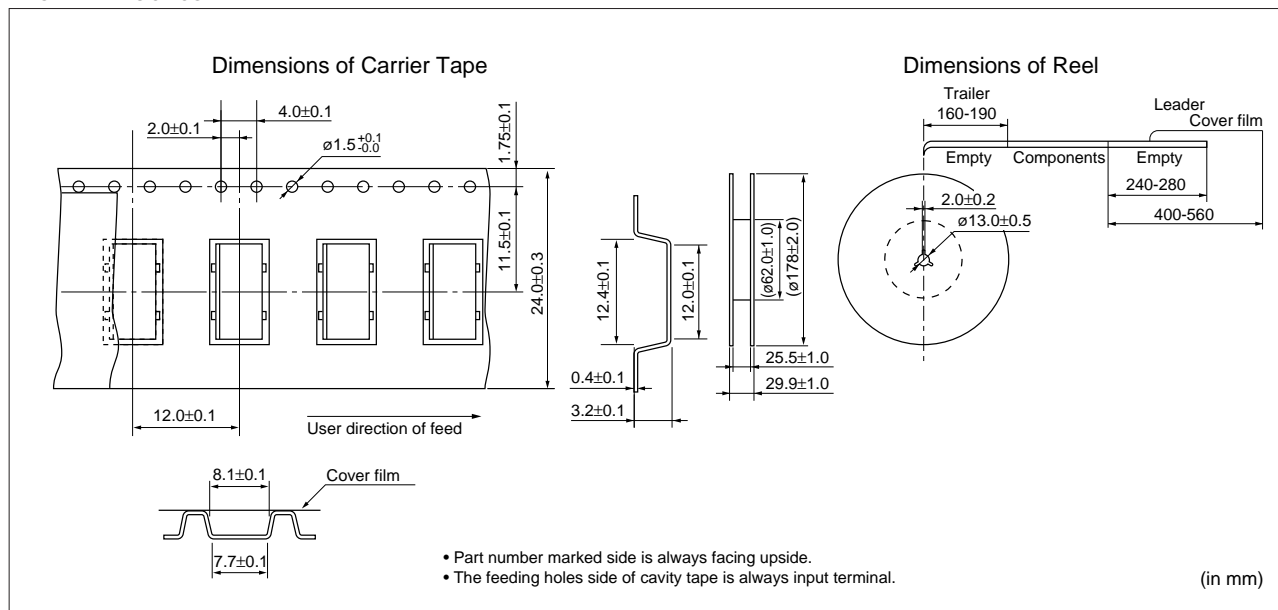

# MHz SMD Type CERAFIL® Packaging

## Minimum Quantity

Part Number	ø180mm	ø330mm
SFECF	2,000	
SFSCE	1,500	

## SFECF10M7 Series

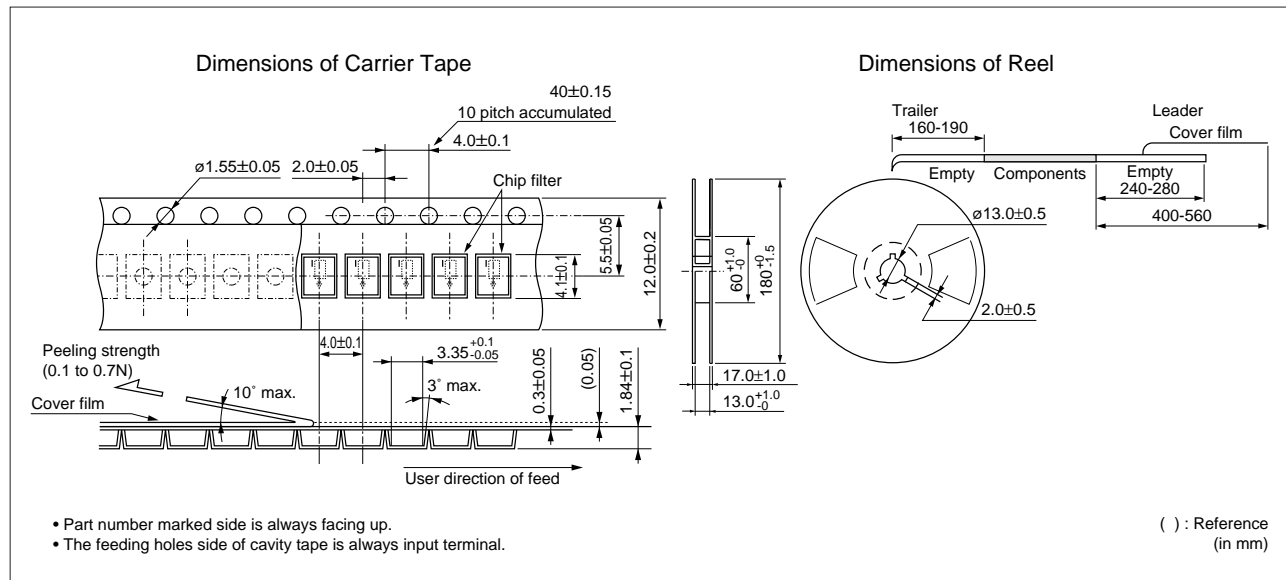

## SFSCE10M7 Series

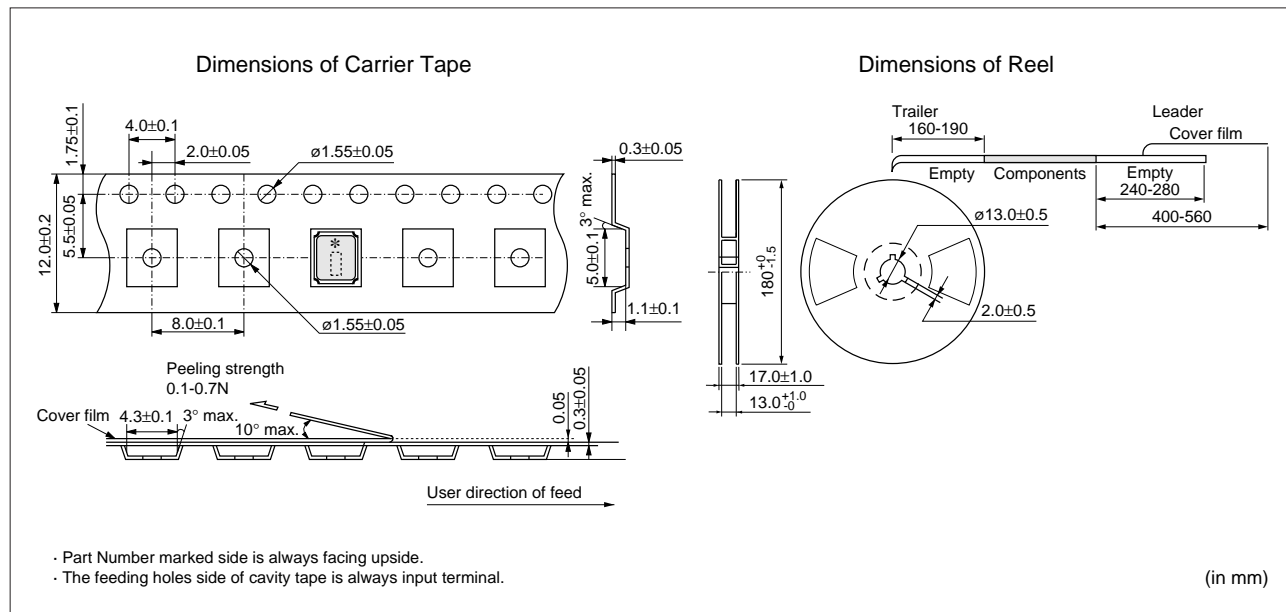



# Ceramic Filters (CERAFIL®)/Ceramic Discriminators for Communications Equipment



## CERAFIL® Plastic Case General Use CFULA Series

CFULA series are high selectivity ceramic filters, which consist of 4 ceramic elements connected in a ladder form.  
 Most suitable for digital communications and cellular phones because of their improved GDT characteristics.

### ■ Features

1. High selectivity
2. A variety of bandwidths available
3. Excellent GDT characteristics are available within pass bandwidth.
4. Easily mounted on a printed circuit board
5. Operating temperature range: -20 to +80 (degrees C)  
 Storage temperature range: -40 to +85 (degrees C)

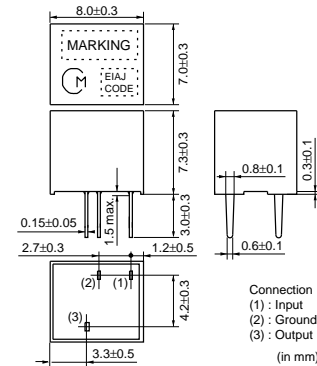

Part Number	Center Frequency (fo) (kHz)	6dB Bandwidth (kHz)	Stop Bandwidth (kHz)	Stop Band Attenuation (dB)	Insertion Loss (dB)	Input/Output Impedance (ohm)
CFULA455KB2A-B0	455 ±2.0kHz	fn±15.0 min.	fn±30.0 max. [within 40dB]	27 min. [within fn±100kHz]	4.0 max. [at minimum loss point]	1500
CFULA455KC2A-B0	455 ±2.0kHz	fn±12.5 min.	fn±24.0 max. [within 40dB]	27 min. [within fn±100kHz]	4.0 max. [at minimum loss point]	1500
CFULA455KD4A-B0	455 ±1.5kHz	fn±10.0 min.	fn±20.0 max. [within 40dB]	27 min. [within fn±100kHz]	4.0 max. [at minimum loss point]	1500
CFULA455KE4A-B0	455 ±1.5kHz	fn±7.5 min.	fn±15.0 max. [within 40dB]	27 min. [within fn±100kHz]	6.0 max. [at minimum loss point]	1500
CFULA455KF4A-B0	455 ±1.5kHz	fn±6.0 min.	fn±12.5 max. [within 40dB]	27 min. [within fn±100kHz]	6.0 max. [at minimum loss point]	2000
CFULA455KG1A-B0	455 ±1.0kHz	fn±4.5 min.	fn±10.0 max. [within 40dB]	25 min. [within fn±100kHz]	6.0 max. [at minimum loss point]	2000
CFULA455KH1A-B0	455 ±1.0kHz	fn±3.0 min.	fn±9.0 max. [within 40dB]	35 min. [within fn±100kHz]	6.0 max. [at minimum loss point]	2000

Center frequency (fo) defined by the center of 6dB bandwidth.

(fn) means nominal center frequency 455kHz.

For safety purposes, connect the output of filters to the IF amplifier through a D.C. blocking capacitor. Avoid applying a direct current to the output of ceramic filters.

The order quantity should be an integral multiple of the "Minimum Quantity" shown in package page in this catalog.

### ■ Test Circuit

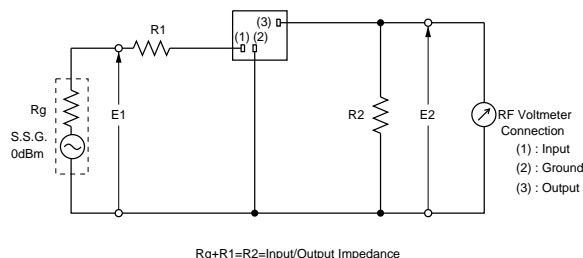

## ■ Frequency Characteristics

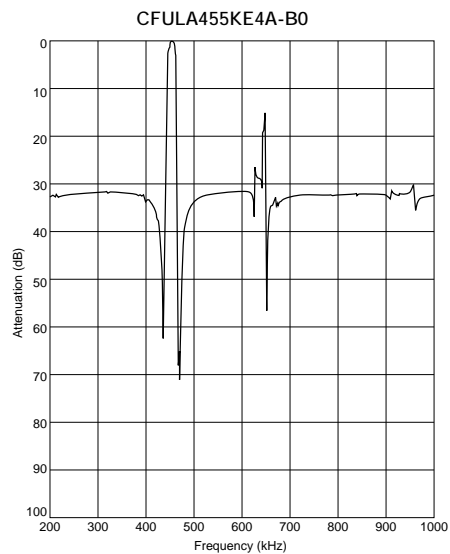
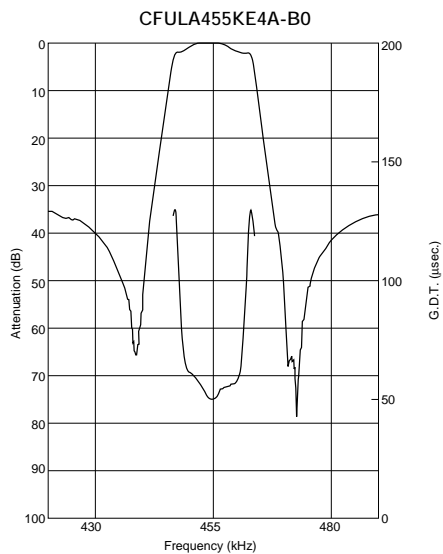

# Ceramic Filters (CERAFIL®)/Ceramic Discriminators for Communications Equipment



## CERAFIL® Plastic Case General Use CFWLA Series

Ceramic filter CFWLA series are low profile high selectivity ceramic filters which use 6 elements in ladder form.

They are best suitable to high-class transceivers, cordless telephones and amateur radios.

### ■ Features

1. Low profile, high selectivity
2. Available bandwidths are B to J as standard
3. Easily mountable on any PC board
4. Operating temperature range: -20 to +80 (degrees C)  
Storage temperature range: -40 to +85 (degrees C)

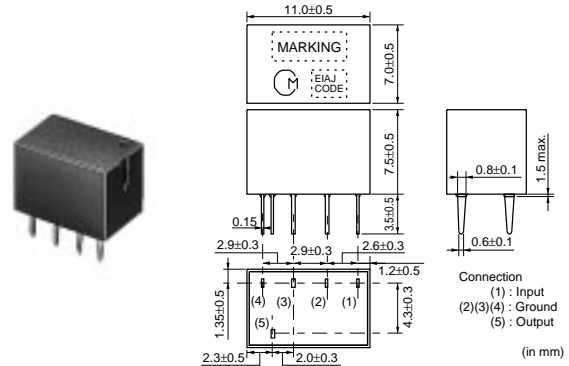

Part Number	Nominal Center Frequency (fn) (kHz)	6dB Bandwidth (kHz)	Stop Bandwidth (kHz)	Stop Band Attenuation (dB)	Insertion Loss (dB)	Ripple (dB)	Input/Output Impedance (ohm)
<b>CFWLA455KBFA-B0</b>	455.0	fn±15.0 min.	fn±30.0 max. [within 50dB]	35 min. [within fn±100kHz]	4.0 max. [at minimum loss point]	3.0 max. [within fn±10kHz]	1500
<b>CFWLA455KCFA-B0</b>	455.0	fn±12.5 min.	fn±24.0 max. [within 50dB]	35 min. [within fn±100kHz]	4.0 max. [at minimum loss point]	3.0 max. [within fn±8kHz]	1500
<b>CFWLA455KDFA-B0</b>	455.0	fn±10.0 min.	fn±20.0 max. [within 50dB]	35 min. [within fn±100kHz]	4.0 max. [at minimum loss point]	3.0 max. [within fn±7kHz]	1500
<b>CFWLA455KEFA-B0</b>	455.0	fn±7.5 min.	fn±15.0 max. [within 50dB]	35 min. [within fn±100kHz]	6.0 max. [at minimum loss point]	3.0 max. [within fn±5kHz]	1500
<b>CFWLA455KFFA-B0</b>	455.0	fn±6.0 min.	fn±12.5 max. [within 50dB]	35 min. [within fn±100kHz]	6.0 max. [at minimum loss point]	3.0 max. [within fn±4kHz]	2000
<b>CFWLA455KGFA-B0</b>	455.0	fn±4.5 min.	fn±10.0 max. [within 50dB]	35 min. [within fn±100kHz]	6.0 max. [at minimum loss point]	2.0 max. [within fn±3kHz]	2000
<b>CFWLA455KHFA-B0</b>	455.0	fn±3.0 min.	fn±9.0 max. [within 50dB]	60 min. [within fn±100kHz]	6.0 max. [at minimum loss point]	2.0 max. [within fn±2kHz]	2000
<b>CFWLA455KJFA-B0</b>	455.0	fn±2.0 min.	fn±7.5 max. [within 50dB]	60 min. [within fn±100kHz]	7.0 max. [at minimum loss point]	2.0 max. [within fn±1.5kHz]	2000

For safety purposes, connect the output of filters to the IF amplifier through a D.C. blocking capacitor. Avoid applying a direct current to the output of ceramic filters. The order quantity should be an integral multiple of the "Minimum Quantity" shown in package page in this catalog.

### ■ Test Circuit

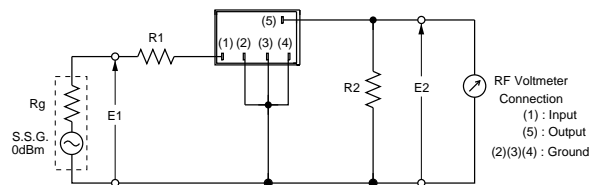

$R_g + R_1 = R_2 = \text{Input/Output Impedance}$

## ■ Frequency Characteristics

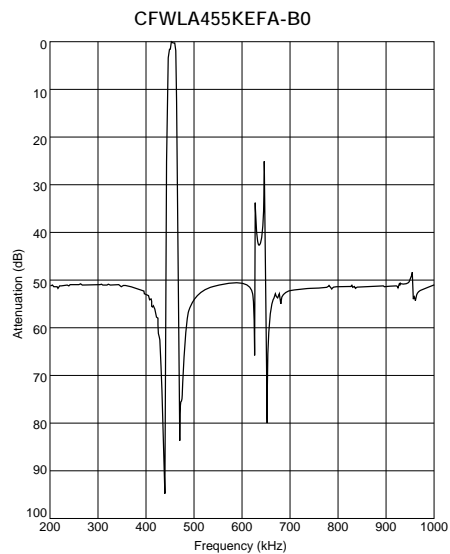
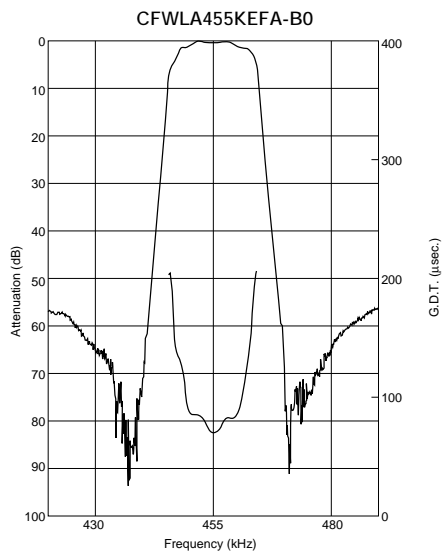

# Ceramic Filters (CERAFIL®)/Ceramic Discriminators for Communications Equipment



## CERAFIL® Plastic Case Miniaturized Type CFULB Series

CFULB series ceramic filters are miniature, high performance ceramic filters composed of piezoelectric elements connected in a ladder form.

These filters, only 6.3mm high, are 65% the volume of conventional types.

They are well suited for miniaturizing various kinds of communications equipment, pocket pagers, car radios, cordless telephones and mobile telephones.

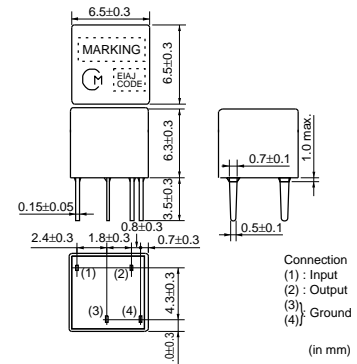

### ■ Features

1. Miniature and high selectivity
2. A variety of bandwidths are available
3. Operating temperature range: -20 to +80 (degrees C)  
Storage temperature range: -40 to +85 (degrees C)

Part Number	Center Frequency (fo) (kHz)	6dB Bandwidth (kHz)	Stop Bandwidth (kHz)	Stop Band Attenuation (dB)	Insertion Loss (dB)	Input/Output Impedance (ohm)
CFULB455KB2A-B0	455 ±2.0kHz	fn±15.0 min.	fn±30.0 max. [within 40dB]	27 min. [within fn±100kHz]	4.0 max. [at minimum loss point]	1500
CFULB455KC2A-B0	455 ±2.0kHz	fn±12.5 min.	fn±24.0 max. [within 40dB]	27 min. [within fn±100kHz]	4.0 max. [at minimum loss point]	1500
CFULB455KD4A-B0	455 ±1.5kHz	fn±10.0 min.	fn±20.0 max. [within 40dB]	27 min. [within fn±100kHz]	4.0 max. [at minimum loss point]	1500
CFULB455KE4A-B0	455 ±1.5kHz	fn±7.5 min.	fn±15.0 max. [within 40dB]	27 min. [within fn±100kHz]	6.0 max. [at minimum loss point]	1500
CFULB455KF4A-B0	455 ±1.5kHz	fn±6.0 min.	fn±12.5 max. [within 40dB]	27 min. [within fn±100kHz]	6.0 max. [at minimum loss point]	2000
CFULB455KG1A-B0	455 ±1.0kHz	fn±4.5 min.	fn±10.0 max. [within 40dB]	25 min. [within fn±100kHz]	6.0 max. [at minimum loss point]	2000
CFULB455KH1A-B0	455 ±1.0kHz	fn±3.0 min.	fn±9.0 max. [within 40dB]	35 min. [within fn±100kHz]	6.0 max. [at minimum loss point]	2000
CFULB455KJ1A-B0	455 ±1.0kHz	fn±2.0 min.	fn±7.5 max. [within 40dB]	35 min. [within fn±100kHz]	6.0 max. [at minimum loss point]	2000

Center frequency (fo) defined by the center of 6dB bandwidth.

(fn) means nominal center frequency 455kHz.

CFULB455K\_series filters are 4-element ceramic filters and miniature versions of CFULA455K\_series.

For safety purposes, connect the output of filters to the IF amplifier through a D.C. blocking capacitor. Avoid applying a direct current to the output of ceramic filters.

The order quantity should be an integral multiple of the "Minimum Quantity" shown in package page in this catalog.

## ■ Test Circuit

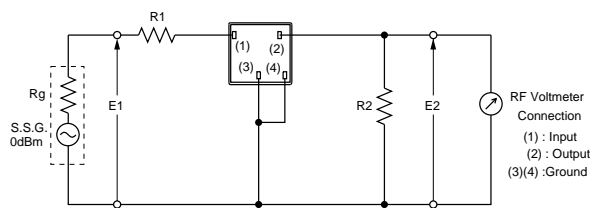

$R_g + R_1 = R_2 = \text{Input/Output Impedance}$

## ■ Frequency Characteristics

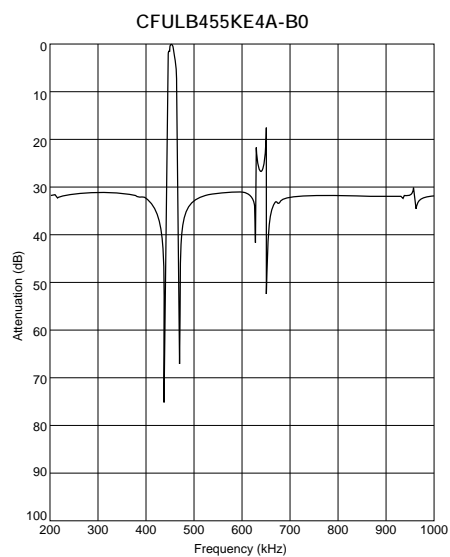
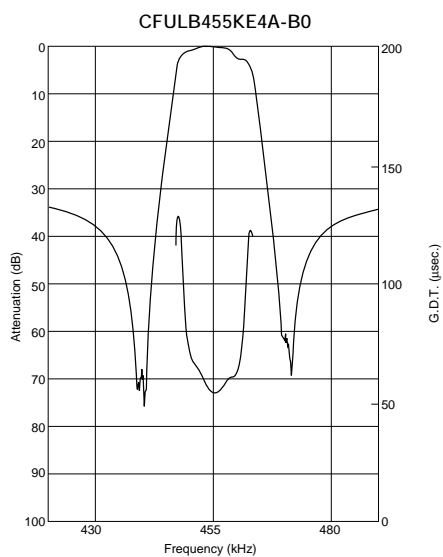

# Ceramic Filters (CERAFIL®)/Ceramic Discriminators for Communications Equipment



## CERAFIL® Plastic Case Miniaturized Type CFWLB Series

CFWLB series ceramic filters are miniature, high performance ceramic filters composed of piezoelectric elements connected in a ladder form.

These filters, only 6.3mm high, are 67% the volume of conventional types.

They are well suited for miniaturizing various kinds of communications equipment, pocket pagers, pagers, car radios, cordless telephones and mobile telephones.

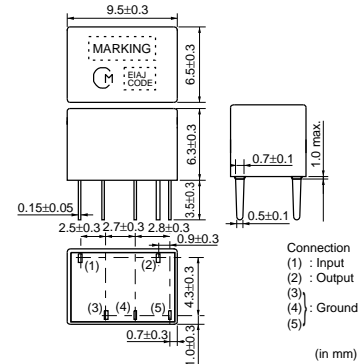

### ■ Features

1. Miniature and high selectivity
2. A variety of bandwidths are available.
3. Operating temperature range: -20 to +80 (degrees C)  
Storage temperature range: -40 to +85 (degrees C)

Part Number	Nominal Center Frequency (fn) (kHz)	6dB Bandwidth (kHz)	Stop Bandwidth (kHz)	Stop Band Attenuation (dB)	Insertion Loss (dB)	Input/Output Impedance (ohm)
CFWLB455KBFA-B0	455.0	fn±15.0 min.	fn±30.0 max. [within 50dB]	35 min. [within fn±100kHz]	4.0 max. [at minimum loss point]	1500
CFWLB455KCFA-B0	455.0	fn±12.5 min.	fn±24.0 max. [within 50dB]	35 min. [within fn±100kHz]	4.0 max. [at minimum loss point]	1500
CFWLB455KDFA-B0	455.0	fn±10.0 min.	fn±20.0 max. [within 50dB]	35 min. [within fn±100kHz]	4.0 max. [at minimum loss point]	1500
CFWLB455KEFA-B0	455.0	fn±7.5 min.	fn±15.0 max. [within 50dB]	35 min. [within fn±100kHz]	6.0 max. [at minimum loss point]	1500
CFWLB455KEFA004-B0	455.0	fn±7.5 min.	fn±15.0 max. [within 60dB]	60 min. [within fn±15kHz to 30kHz]	5.0 max. [at fn]	1500
CFWLB455KFFA-B0	455.0	fn±6.0 min.	fn±12.5 max. [within 50dB]	35 min. [within fn±100kHz]	6.0 max. [at minimum loss point]	2000
CFWLB455KGFA-B0	455.0	fn±4.5 min.	fn±10.0 max. [within 50dB]	35 min. [within fn±100kHz]	6.0 max. [at minimum loss point]	2000
CFWLB455KHFA-B0	455.0	fn±3.0 min.	fn±9.0 max. [within 50dB]	55 min. [within fn±100kHz]	6.0 max. [at minimum loss point]	2000
CFWLB455KJFA-B0	455.0	fn±2.0 min.	fn±7.0 max. [within 50dB]	55 min. [within fn±100kHz]	7.0 max. [at minimum loss point]	2000

CFWLB455K\_series filters are 4-element ceramic filters and miniature versions of CFWLA455K\_series.

For safety purposes, connect the output of filters to the IF amplifier through a D.C. blocking capacitor. Avoid applying a direct current to the output of ceramic filters.

The order quantity should be an integral multiple of the "Minimum Quantity" shown in package page in this catalog.

## ■ Test Circuit

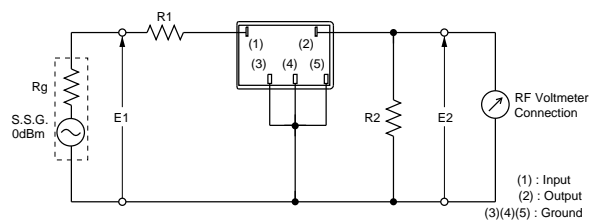

$R_g+R_1=R_2=\text{Input/Output Impedance}$

## ■ Frequency Characteristics

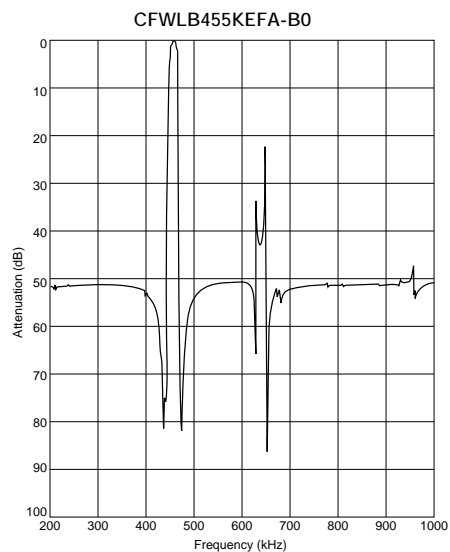
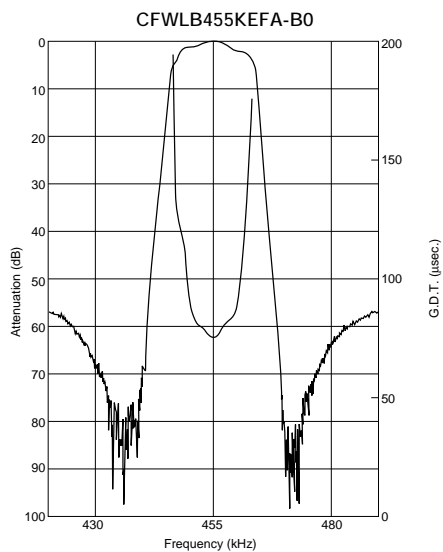



# Ceramic Filters (CERAFIL®)/Ceramic Discriminators for Communications Equipment



## CERAFIL® Plastic Case Group Delay Flat Type CFULA\_Y Series

CFULA\_Y series are high selectivity ceramic filters, which consist of 4 ceramic elements connected in a ladder form.  
 Most suitable for digital communications and cellular phones because of their improved GDT characteristics.

### ■ Features

1. High selectivity
2. A variety of bandwidths are available.
3. Excellent GDT characteristics are available within pass bandwidth.
4. Easily mounted on a printed circuit board
5. Operating temperature range: -20 to +80 (degrees C)  
 Storage temperature range: -40 to +85 (degrees C)

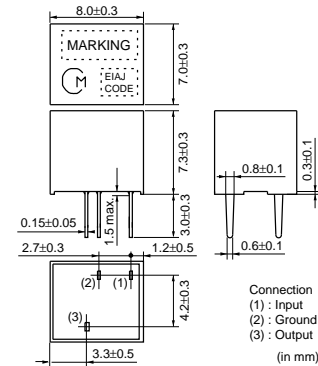

Part Number	Center Frequency (fo) (kHz)	6dB Bandwidth (kHz)	Stop Bandwidth (kHz)	Stop Band Attenuation (dB)	Insertion Loss (dB)	GDT Deviation (μs)	Input/Output Impedance (ohm)
CFULA455KB4Y-B0	455 ±1.5kHz	fn±15.0 min.	fn±35.0 max. [within 40dB]	25 min. [within fn±100kHz]	5.0 max. [at minimum loss point]	15.0 max. [within fn±10kHz]	1500
CFULA455KC4Y-B0	455 ±1.5kHz	fn±12.5 min.	fn±30.0 max. [within 40dB]	25 min. [within fn±100kHz]	6.0 max. [at minimum loss point]	15.0 max. [within fn±8kHz]	1500
CFULA455KD1Y-B0	455 ±1.0kHz	fn±10.0 min.	fn±25.0 max. [within 40dB]	23 min. [within fn±100kHz]	7.0 max. [at minimum loss point]	20.0 max. [within fn±7kHz]	1500
CFULA455KE1Y-B0	455 ±1.0kHz	fn±7.5 min.	fn±20.0 max. [within 40dB]	23 min. [within fn±100kHz]	8.0 max. [at minimum loss point]	20.0 max. [within fn±5kHz]	1500
CFULA455KF1Y-B0	455 ±1.0kHz	fn±6.0 min.	fn±17.5 max. [within 40dB]	23 min. [within fn±100kHz]	9.0 max. [at minimum loss point]	20.0 max. [within fn±4kHz]	2000
CFULA455KG1Y-B0	455 ±1.0kHz	fn±4.5 min.	fn±15.0 max. [within 40dB]	23 min. [within fn±100kHz]	10.0 max. [at minimum loss point]	20.0 max. [within fn±3kHz]	2000

Center frequency (fo) defined by the center of 6dB bandwidth.

(fn) means nominal center frequency 455kHz.

For safety purposes, connect the output of filters to the IF amplifier through a D.C. blocking capacitor. Avoid applying a direct current to the output of ceramic filters.

The order quantity should be an integral multiple of the "Minimum Quantity" shown in package page in this catalog.

### ■ Test Circuit

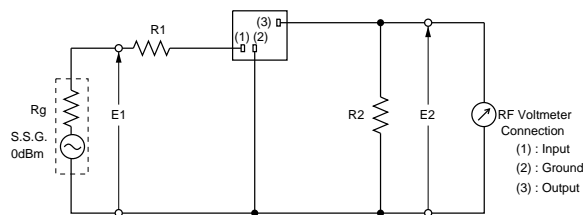

$R_g + R_1 = R_2 = \text{Input/Output Impedance}$

## ■ Frequency Characteristics

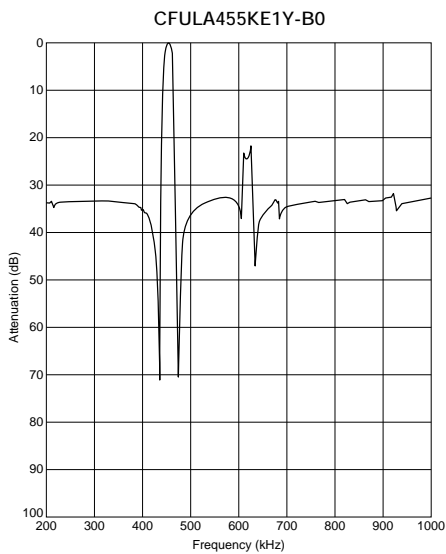
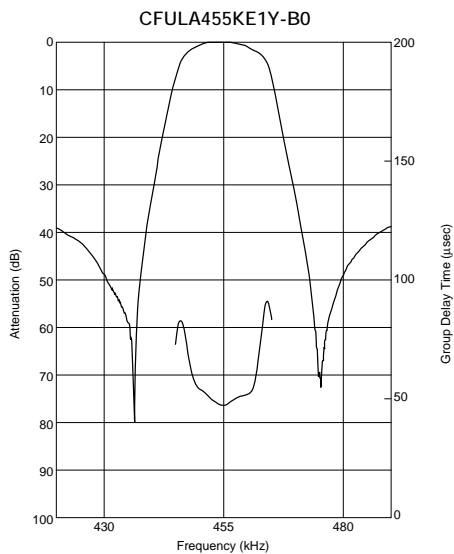

# Ceramic Filters (CERAFIL®)/Ceramic Discriminators for Communications Equipment



## CERAFIL® Plastic Case Group Delay Flat Type CFWLA\_Y Series

CFWLA\_Y series are high selectivity ceramic filters, which consist of 6 ceramic elements connected in a ladder form.

Most suitable for digital communications and mobile telephones because of their improved GDT characteristics.

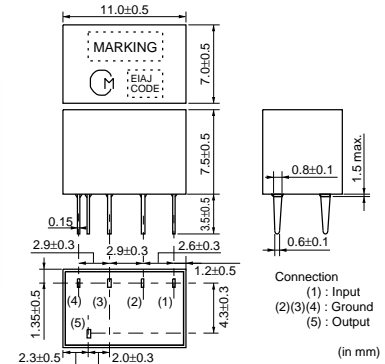

### ■ Features

1. High selectivity
2. A variety of bandwidths are available
3. Excellent GDT characteristics are available within pass bandwidth.
4. Easily mounted on a printed circuit board
5. Operating temperature range: -20 to +80 (degrees C)  
Storage temperature range: -40 to +85 (degrees C)

Part Number	Center Frequency (fo) (kHz)	6dB Bandwidth (kHz)	Stop Bandwidth (kHz)	Stop Band Attenuation (dB)	Insertion Loss (dB)	GDT Deviation (μs)	Input/Output Impedance (ohm)
CFWLA455KB4Y-B0	455 ±1.5kHz	fn±15.0 min.	fn±35.0 max. [within 50dB]	40 min. [within fn±100kHz]	6.0 max. [at minimum loss point]	30.0 max. [within fn±10kHz]	1500
CFWLA455KC4Y-B0	455 ±1.5kHz	fn±12.5 min.	fn±30.0 max. [within 50dB]	40 min. [within fn±100kHz]	7.0 max. [at minimum loss point]	30.0 max. [within fn±8kHz]	1500
CFWLA455KD1Y-B0	455 ±1.0kHz	fn±10.0 min.	fn±25.0 max. [within 50dB]	40 min. [within fn±100kHz]	8.0 max. [at minimum loss point]	30.0 max. [within fn±7kHz]	1500
CFWLA455KE1Y-B0	455 ±1.0kHz	fn±7.5 min.	fn±20.0 max. [within 50dB]	40 min. [within fn±100kHz]	9.0 max. [at minimum loss point]	30.0 max. [within fn±5kHz]	1500
CFWLA455KF1Y-B0	455 ±1.0kHz	fn±6.0 min.	fn±17.5 max. [within 50dB]	40 min. [within fn±100kHz]	10.0 max. [at minimum loss point]	40.0 max. [within fn±4kHz]	2000
CFWLA455KG1Y-B0	455 ±1.0kHz	fn±4.5 min.	fn±15.0 max. [within 50dB]	40 min. [within fn±100kHz]	11.0 max. [at minimum loss point]	40.0 max. [within fn±3kHz]	2000

Center frequency (fo) defined by the center of 6dB bandwidth.

(fn) means nominal center frequency 455kHz.

For safety purposes, connect the output of filters to the IF amplifier through a D.C. blocking capacitor. Avoid applying a direct current to the output of ceramic filters.

The order quantity should be an integral multiple of the "Minimum Quantity" shown in package page in this catalog.

### ■ Test Circuit

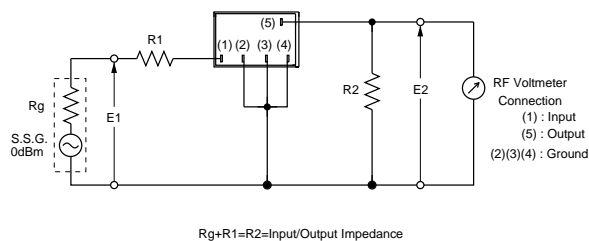

## ■ Frequency Characteristics

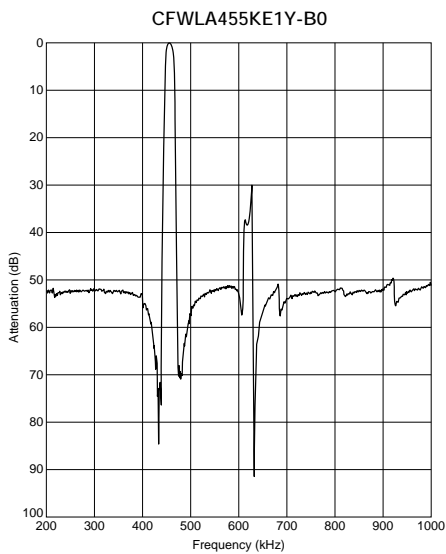
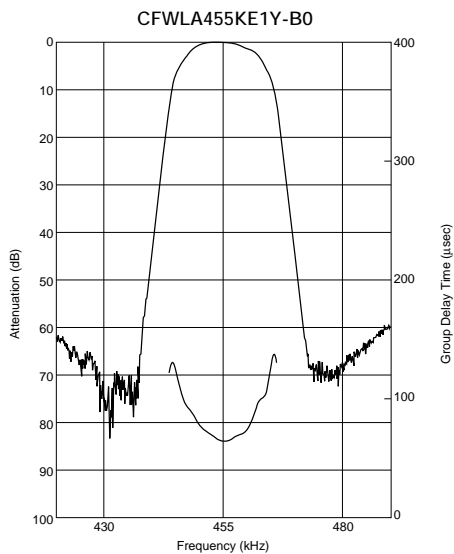

# Ceramic Filters (CERAFIL®)/Ceramic Discriminators for Communications Equipment



## CERAFIL® Plastic Case Group Delay Flat Type Miniaturized Type CFULB\_Y Series

Ceramic filter CFULB\_Y series are miniature and high performance filters. These filters, only 6.3mm high, are 65% the volume of conventional types. Well suited for miniaturizing communications equipment, especially for a cellular phone.

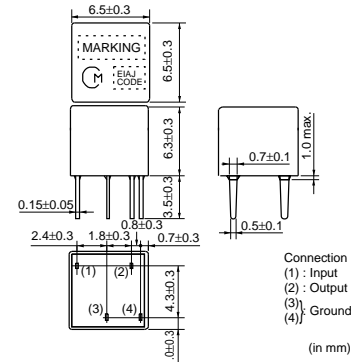

### ■ Features

1. Miniature, flat GDT characteristics
2. Suitable for a cellular phone
3. A variety of bandwidths are available.
4. Operating temperature range: -20 to +80 (degrees C)  
Storage temperature range: -40 to +85 (degrees C)

Part Number	Center Frequency (fo) (kHz)	6dB Bandwidth (kHz)	Stop Bandwidth (kHz)	Stop Band Attenuation (dB)	Insertion Loss (dB)	GDT Deviation (μs)	Input/Output Impedance (ohm)
CFULB455KB4Y-B0	455 ±1.5kHz	fn±15.0 min.	fn±35.0 max. [within 40dB]	25 min. [within fn±100kHz]	5.0 max. [at minimum loss point]	15.0 max. [within fn±10kHz]	1500
CFULB455KC4Y-B0	455 ±1.5kHz	fn±12.5 min.	fn±30.0 max. [within 40dB]	25 min. [within fn±100kHz]	6.0 max. [at minimum loss point]	15.0 max. [within fn±8kHz]	1500
CFULB455KD1Y-B0	455 ±1.0kHz	fn±10.0 min.	fn±25.0 max. [within 40dB]	23 min. [within fn±100kHz]	7.0 max. [at minimum loss point]	20.0 max. [within fn±7kHz]	1500
CFULB455KE1Y-B0	455 ±1.0kHz	fn±7.5 min.	fn±20.0 max. [within 40dB]	23 min. [within fn±100kHz]	8.0 max. [at minimum loss point]	20.0 max. [within fn±5kHz]	1500
CFULB455KF1Y-B0	455 ±1.0kHz	fn±6.0 min.	fn±17.5 max. [within 40dB]	23 min. [within fn±100kHz]	9.0 max. [at minimum loss point]	20.0 max. [within fn±4kHz]	2000
CFULB455KG1Y-B0	455 ±1.0kHz	fn±4.5 min.	fn±15.0 max. [within 40dB]	23 min. [within fn±100kHz]	10.0 max. [at minimum loss point]	20.0 max. [within fn±3kHz]	2000

Center frequency (fo) defined by the center of 6dB bandwidth.

(fn) means nominal center frequency 455kHz.

CFULB455K\_Y series filters are 4-element ceramic filters and miniature versions of CFULA455K\_Y series.

For safety purposes, connect the output of filters to the IF amplifier through a D.C. blocking capacitor. Avoid applying a direct current to the output of ceramic filters.

The order quantity should be an integral multiple of the "Minimum Quantity" shown in package page in this catalog.

### ■ Test Circuit

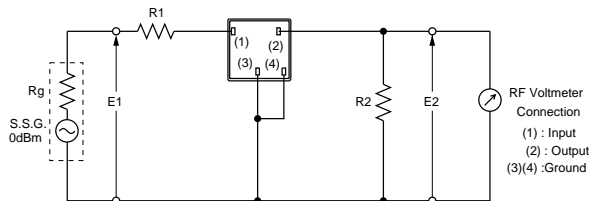

$R_g + R_1 = R_2 = \text{Input/Output Impedance}$

## ■ Frequency Characteristics

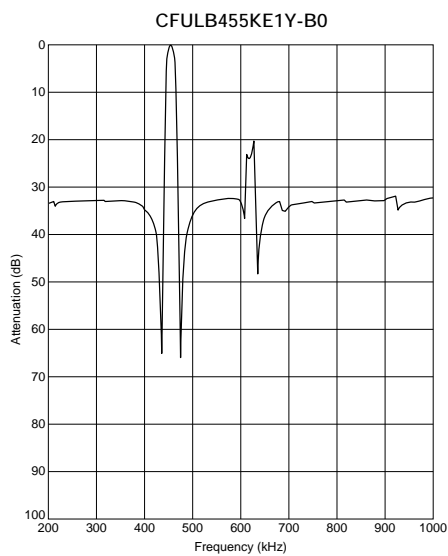
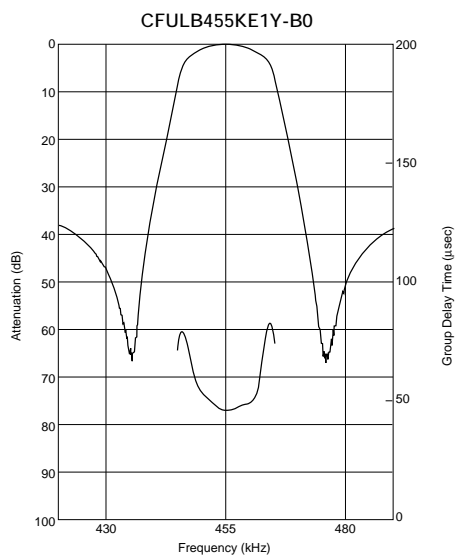

# Ceramic Filters (CERAFIL®)/Ceramic Discriminators for Communications Equipment



## CERAFIL® Plastic Case Group Delay Flat Type CFWLB\_Y Series

Ceramic filter CFWLB\_Y series are miniature and high-performance filters. These filters, only 6.3mm high, are 67% the volume of conventional types. Well suited for miniaturizing communications equipment, especially for a cellular phone.

### ■ Features

1. Miniature, flat GDT characteristics
2. Suitable for a cellular phone
3. A variety of bandwidths are available.
4. Operating temperature range: -20 to +80 (degrees C)  
Storage temperature range: -40 to +85 (degrees C)

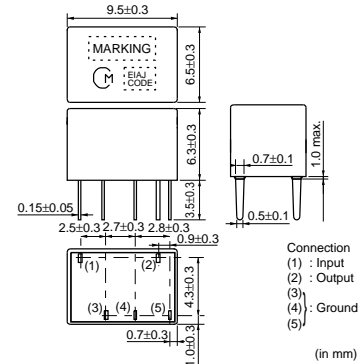

Part Number	Center Frequency (fo) (kHz)	6dB Bandwidth (kHz)	Stop Bandwidth (kHz)	Stop Band Attenuation (dB)	Insertion Loss (dB)	GDT Deviation (μs)	Input/Output Impedance (ohm)
CFWLB455KB4Y-B0	455 ±1.5kHz	fn±15.0 min.	fn±30.0 max. [within 50dB]	40 min. [within fn±100kHz]	6.0 max. [at minimum loss point]	30.0 max. [within fn±10kHz]	1500
CFWLB455KC4Y-B0	455 ±1.5kHz	fn±12.5 min.	fn±27.5 max. [within 50dB]	40 min. [within fn±100kHz]	7.0 max. [at minimum loss point]	30.0 max. [within fn±8kHz]	1500
CFWLB455KD1Y-B0	455 ±1.0kHz	fn±10.0 min.	fn±25.0 max. [within 50dB]	40 min. [within fn±100kHz]	8.0 max. [at minimum loss point]	30.0 max. [within fn±7kHz]	1500
CFWLB455KE1Y-B0	455 ±1.0kHz	fn±7.5 min.	fn±20.0 max. [within 50dB]	40 min. [within fn±100kHz]	9.0 max. [at minimum loss point]	30.0 max. [within fn±5kHz]	1500
CFWLB455KF1Y-B0	455 ±1.0kHz	fn±6.0 min.	fn±17.5 max. [within 50dB]	40 min. [within fn±100kHz]	10.0 max. [at minimum loss point]	40.0 max. [within fn±4kHz]	2000
CFWLB455KG1Y-B0	455 ±1.0kHz	fn±4.5 min.	fn±15.0 max. [within 50dB]	40 min. [within fn±100kHz]	11.0 max. [at minimum loss point]	40.0 max. [within fn±3kHz]	2000

Center frequency (fo) defined by the center of 6dB bandwidth.

(fn) means nominal center frequency 455kHz.

CFWLB455K\_Y series filters are 4-element ceramic filters and miniature versions of CFWLA455K\_Y series.

For safety purposes, connect the output of filters to the IF amplifier through a D.C. blocking capacitor. Avoid applying a direct current to the output of ceramic filters.

The order quantity should be an integral multiple of the "Minimum Quantity" shown in package page in this catalog.

### ■ Test Circuit

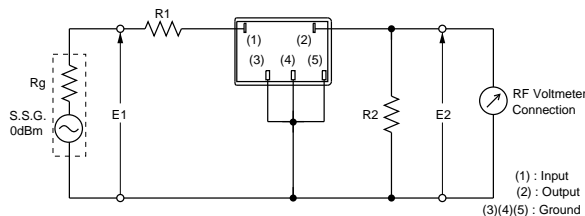

$R_g + R_1 = R_2 = \text{Input/Output Impedance}$

## ■ Frequency Characteristics

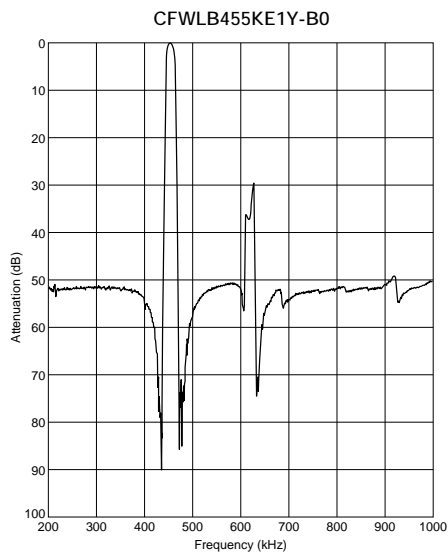
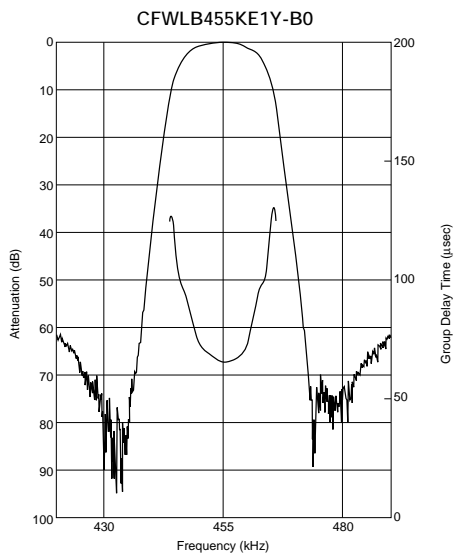



## Plastic Case Type CERAFIL® Minimum Quantity/Notice

### ■ Minimum Quantity

Part Number	Bulk	Magazine
CFULA Series	200	
CFULB Series	250	80
CFWLA Series	150	50
CFWLB Series	150	55

The order quantity should be an integral multiple of the "Minimum Quantity" shown above.

(pcs.)

### ■ Notice (Handling)

1. Do not use this product with bend. The component may be damaged if excessive mechanical stress is applied to it mounted on the printed circuit board.
2. The component will be damaged when an excessive stress is applied.
3. All kinds of re-flow soldering must not be applied on the component.
4. Do not clean or wash the component as it is not hermetically sealed.
5. Do not use strong acidity flux, more than 0.2wt% chlorine content, in flow soldering.
6. In case of covering filter with over coat, conditions such as material of resin, cure temperature, and so on should be evaluated carefully.
7. Accurate test circuit values are required to measure electrical characteristics.  
It may be a cause of miscorrelation if there is any deviation, especially stray capacitance, from the test circuit in the specification.
8. For safety purposes, connect the output of filters to the IF amplifier through a D.C. blocking capacitor. Avoid applying a direct current to the output of ceramic filters.

# Ceramic Filters (CERAFIL®)/Ceramic Discriminators for Communications Equipment



## kHz Type Ceramic Discriminators

Ceramic discriminator consists of wide band piezoelectric resonator.  
 It is ideal for mobile communications equipment due to its small size and light weight.  
 Standard line include products for wide range of applications, from cordless telecom to cellular telephone. Practically adjustment free at the detection circuit, small size is suitable for downsizing.

### ■ Features

1. Small in size and light weight
2. Adjustment free at detection circuit
3. High sensitivity and stability
4. Wide range of standard products are available for various ICs.
5. Operating temperature range: -20 to +80 (degrees C)  
Storage temperature range: -40 to +85 (degrees C)

CDBKB Series

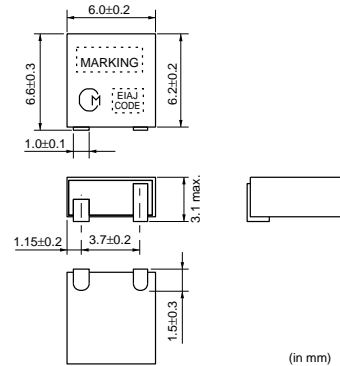

CDBLA Series

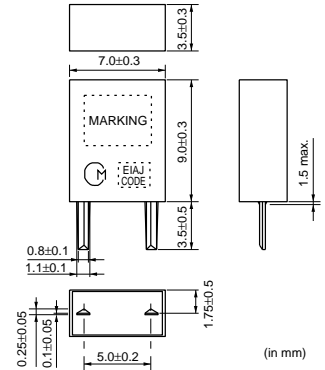

CDBLB\_CAX Series

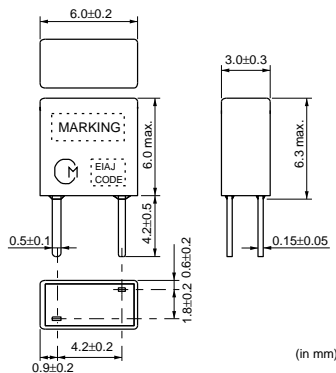

CDBLB\_CAY Series

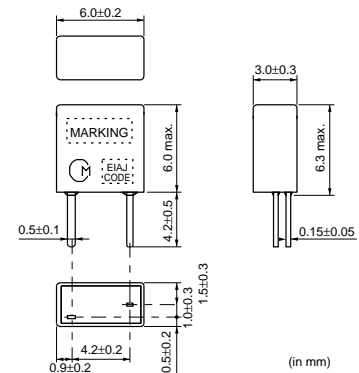

### Specified by Impedance Characteristics (Type 1)

Part Number	Nominal Center Frequency (fm) (kHz)	Inclination of Impedance Curve(1)	Inclination of Impedance Curve(2)	Capacitance (C)	IC	IC Maker	Type
CDBLB450KCAX80-R0	450	-	-	-	MB15H121	FUJITSU	Lead
CDBLB455KCAX02-B0	455	447.0±1.5kHz (at  Z =2.05kohm)	463.0±1.5kHz (at  Z =10.0kohm)	140pF±20%	TA8104F	TOSHIBA	Lead
CDBLB455KCAX31-B0	455	447.0±1.5kHz (at  Z =2.05kohm)	463.0±1.5kHz (at  Z =10.0kohm)	140pF±20%	TA31141	TOSHIBA	Lead

For safety purposes, avoid applying a direct current between the terminals.  
 The order quantity should be an integral multiple of the "Minimum Quantity" shown in package page in this catalog.

## ■ Impedance Curve

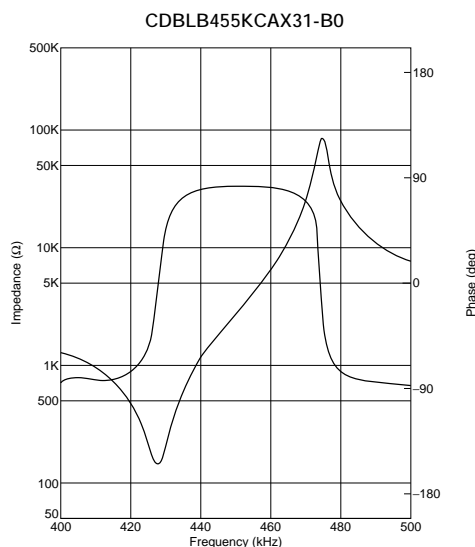
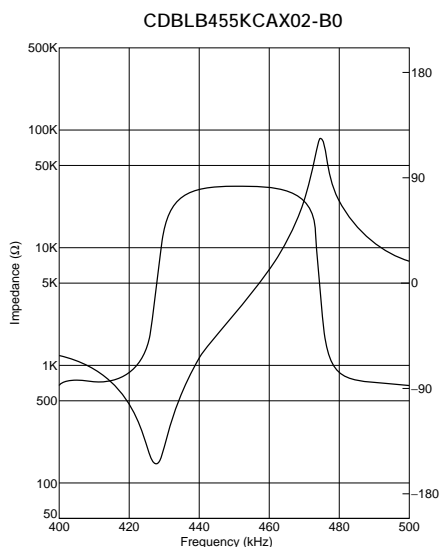

### Specified by Impedance Characteristics (Type 2)

Part Number	Nominal Center Frequency (fn)	Anti-resonant Frequency (Fa)	Delta F (Fa-Fr)	Resonant Resistance (R)	Capacitance (C)	IC	IC Maker	Type
CDBKB455KCAX33-R0	-	462.0±1.5kHz	40±4.0kHz	200ohm max.	150pF±20%	CXA1474	SONY	SMD
CDBLA455KCAY03-B0	-	455.0±1.5kHz	48±5.0kHz	70ohm max.	600pF±20%	CXA1184M	SONY	Lead
CDBLB455KCAY03-B0	-	455.0±1.5kHz	46±5.0kHz	70ohm max.	550pF±20%	CXA1184M	SONY	Lead
CDBLB455KCAX15-B0	-	463.5±1.0kHz	43±2.0kHz	300ohm max.	140pF±20%	CXA1183M	SONY	Lead
CDBLB455KCAX25-B0	-	465.0±1.5kHz	45±4.0kHz	300ohm max.	135pF±20%	CXA1484	SONY	Lead
CDBLB455KCAX33-B0	-	465.0±1.5kHz	45±4.0kHz	300ohm max.	135pF±20%	CXA1474	SONY	Lead

For safety purposes, avoid applying a direct current between the terminals.

The order quantity should be an integral multiple of the "Minimum Quantity" shown in package page in this catalog.

## ■ Impedance Curve

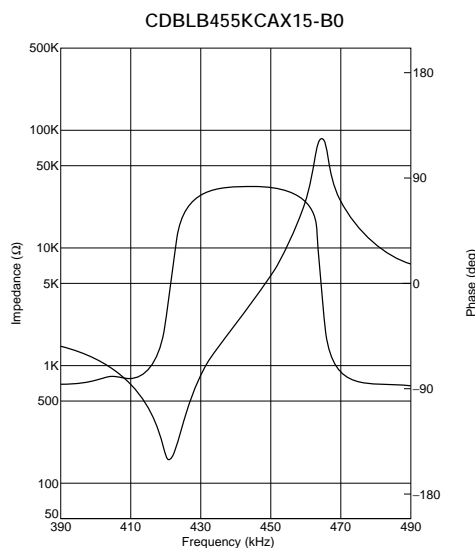
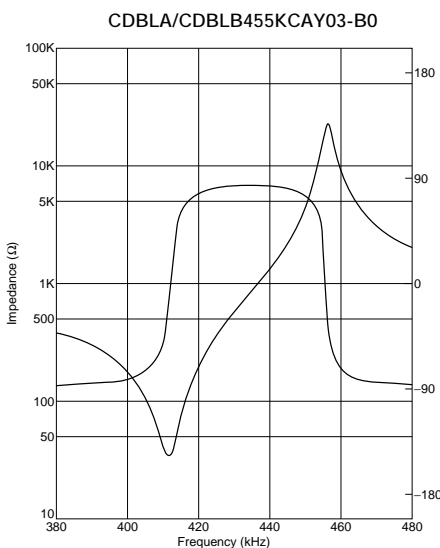

Continued from the preceding page.

### ■ Impedance Curve

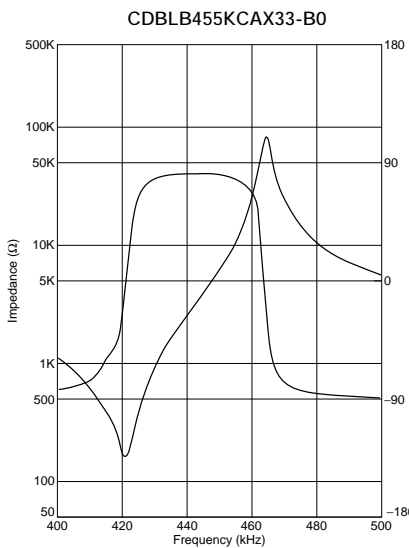
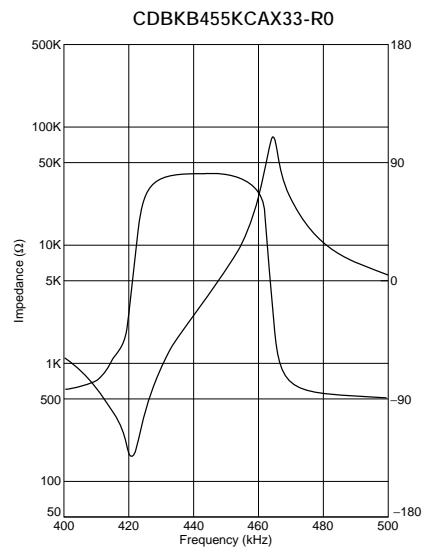
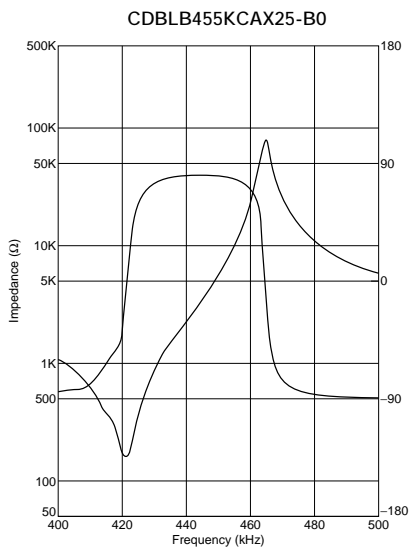

## Specified by Recovered Audio Characteristics

Part Number	Nominal Center Frequency (fn) (kHz)	Recovered Audio 3dB BW (kHz)	Recovered Audio Output (mV)	Distortion (at fn) (%)	Distortion (%)	IC	IC Maker	Type
<b>CDBKB450KCA Y79-R0</b>	450	fn±3.0 min.	145 ±40	-	-	TB32302FG	TOSHIBA	SMD
<b>CDBKB455KCA Y07-R0</b>	455	fn±4.0 min.	350 ±60	3.0 max.	-	MC3357	MOTOROLA	SMD
<b>CDBKB455KCA Y09-R0</b>	455	fn±4.0 min.	120 ±40	1.5 max.	-	NE604N	PHILIPS	SMD
<b>CDBKB455KCA Y13-R0</b>	455	fn±4.0 min.	330 ±50	4.0 max.	-	CXA1003BM	SONY	SMD
<b>CDBKB455KCA Y16-R0</b>	455	fn±4.0 min.	175 ±40	2.0 max.	-	MC3372	MOTOROLA	SMD
<b>CDBKB455KCA Y24-R0</b>	455	fn±4.0 min.	100 ±40	2.0 max.	-	TA31136	TOSHIBA	SMD
<b>CDBKB455KCA Y27-R0</b>	455	fn±4.0 min.	90 ±30	2.0 max.	-	TK10487	TOKO	SMD
<b>CDBKB455KCA Y28-R0</b>	455	fn±4.0 min.	40 ±20	3.0 max.	-	TA31142F	TOSHIBA	SMD
<b>CDBKB455KCA Y29-R0</b>	455	fn±4.0 min.	100 ±30	2.5 max.	-	NE605	PHILIPS	SMD
<b>CDBKB455KCA Y35-R0</b>	455	fn±4.0 min.	100 ±40	2.5 max.	-	TK10930	TOKO	SMD
<b>CDBKB455KCA Y40-R0</b>	455	fn±4.0 min.	40 ±20	3.5 max.	-	TA31145	TOSHIBA	SMD
<b>CDBKB455KCA Y49-R0</b>	455	fn±4.0 min.	45 ±10	3.0 max.	-	MC3361	MOTOROLA	SMD
<b>CDBKB455KCA Y50-R0</b>	455	fn±4.0 min.	64 ±6.4	4.0 max.	-	CXA3117N	SONY	SMD
<b>CDBKB455KCA Y66-R0</b>	455	fn±4.2 min.	40 ±10	4.0 max.	-	NJM2590	JRC	SMD
<b>CDBKB455KCLX36-R0</b>	455	fn±13.0 min.	90 ±30	2.5 max.	5.0 max. [within fn ±6kHz]	NE(SA)606 /NE(SA)616	PHILIPS	SMD
<b>CDBKB455KCLX39-R0</b>	455	fn±11.0 min.	130 ±20	2.5 max.	7.0 max. [within fn ±8kHz]	NE607 /NE617	PHILIPS	SMD
<b>CDBKB455KCLY13-R0</b>	455	fn±13.0 min.	120 ±30	1.5 max.	5.0 max. [within fn ±8kHz]	CXA1003BM	SONY	SMD
<b>CDBLA455KCA Y07-B0</b>	455	fn±4.0 min.	340 ±60	2.5 max.	-	MC3357	MOTOROLA	Lead
<b>CDBLA455KCA Y09-B0</b>	455	fn±5.0 min.	100 min.	1.5 max.	-	NE604N	PHILIPS	Lead
<b>CDBLA455KCA Y13A-B0</b>	455	fn±4.0 min.	350 ±50	3.0 max.	-	CXA1003BM	SONY	Lead
<b>CDBLA455KCA Y16-B0</b>	455	fn±4.0 min.	185 ±40	2.0 max.	-	MC3372	MOTOROLA	Lead
<b>CDBLA455KCA Y24-B0</b>	455	fn±4.0 min.	100 ±40	2.0 max.	-	TA31136	TOSHIBA	Lead
<b>CDBLA455KCA Y28-B0</b>	455	fn±4.0 min.	40 ±20	3.0 max.	-	TA31142	TOSHIBA	Lead
<b>CDBLA455KCA Y34-B0</b>	455	fn±4.0 min.	65 ±20	2.5 max.	-	MC13136	MOTOROLA	Lead
<b>CDBLA455KCLY09-B0</b>	455	fn±15.0 min.	70 ±20	1.5 max.	3.5 max. [within fn ±8kHz]	NE604N	PHILIPS	Lead
<b>CDBLA455KCLY13-B0</b>	455	fn±15.0 min.	110 ±30	1.5 max.	5.0 max. [within fn ±8kHz]	CXA1003BM	SONY	Lead
<b>CDBLB455KCA Y07-B0</b>	455	fn±4.0 min.	340 ±60	3.0 max.	-	MC3357	MOTOROLA	Lead

Continued on the following page.

Continued from the preceding page.

Part Number	Nominal Center Frequency (fn) (kHz)	Recovered Audio 3dB BW (kHz)	Recovered Audio Output (mV)	Distortion (at fn) (%)	Distortion (%)	IC	IC Maker	Type
<b>CDBLB455KCAY13A-B0</b>	455	fn±4.0 min.	350 ±50	3.0 max.	-	CXA1003BM	SONY	Lead
<b>CDBLB455KCAY24-B0</b>	455	fn±4.0 min.	100 ±40	2.0 max.	-	TA31136	TOSHIBA	Lead
<b>CDBLB455KCAY28-B0</b>	455	fn±4.0 min.	40 ±20	3.0 max.	-	TA31142FN	TOSHIBA	Lead
<b>CDBLB455KCAY34-B0</b>	455	fn±4.0 min.	65 ±20	2.5 max.	-	MC13136	MOTOROLA	Lead
<b>CDBLB455KCAY40-B0</b>	455	fn±4.0 min.	40 ±20	3.0 max.	-	TA31145	TOSHIBA	Lead
<b>CDBLB455KCAY42-B0</b>	455	fn±4.0 min.	40 ±15	3.0 max.	-	TK14590 /TK14591	TOKO	Lead
<b>CDBLB455KCAY49-B0</b>	455	fn±4.0 min.	45 ±10	3.0 max.	-	MC3361	MOTOROLA	Lead
<b>CDBLB455KCAY50-B0</b>	455	fn±4.0 min.	64 ±6.4	4.0 max.	-	CXA3117N	SONY	Lead
<b>CDBLB455KCLY09-B0</b>	455	fn±15.0 min.	70 ±20	1.5 max.	3.5 max. [within fn ±8kHz]	NE604N	PHILIPS	Lead
<b>CDBLB455KCLY13-B0</b>	455	fn±15.0 min.	110 ±30	1.5 max.	5.0 max. [within fn ±8kHz]	CXA1003BM	SONY	Lead
<b>CDBLB455KCAX16-B0</b>	455	fn±4.0 min.	185 ±40	2.0 max.	-	MC3372	MOTOROLA	Lead
<b>CDBLB455KCAX18-B0</b>	455	fn±3.0 min.	180 ±40	2.0 max.	-	MC3371	MOTOROLA	Lead
<b>CDBLB455KCAX36-B0</b>	455	fn±3.5 min.	100 ±25	3.5 max.	-	NE606 /NE616	PHILIPS	Lead

For safety purposes, avoid applying a direct current between the terminals.

The order quantity should be an integral multiple of the "Minimum Quantity" shown in package page in this catalog.

## Test Circuit

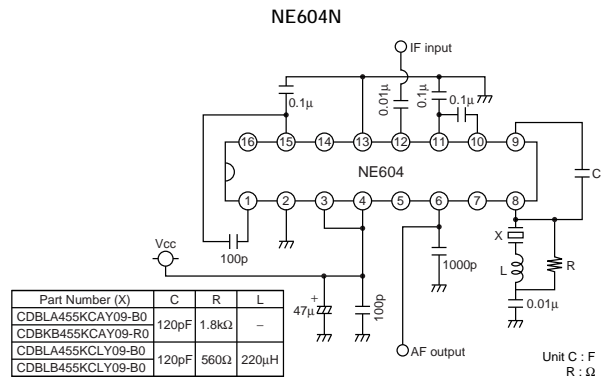
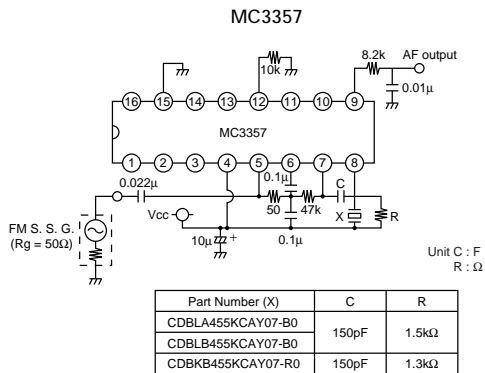

Continued on the following page. ↗

Continued from the preceding page.

Test Circuit

CXA1003BM

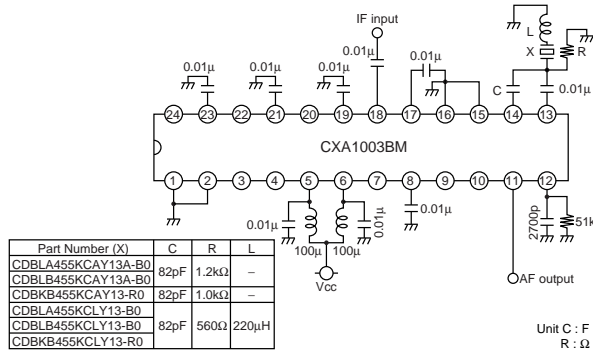

MC3372

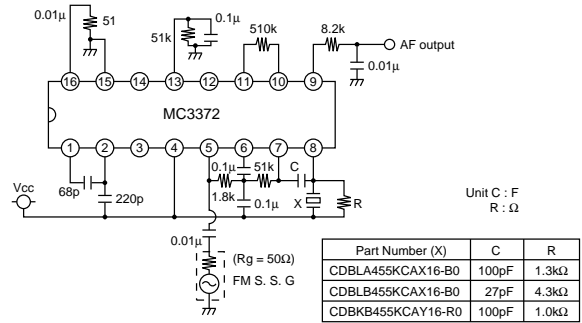

MC3371

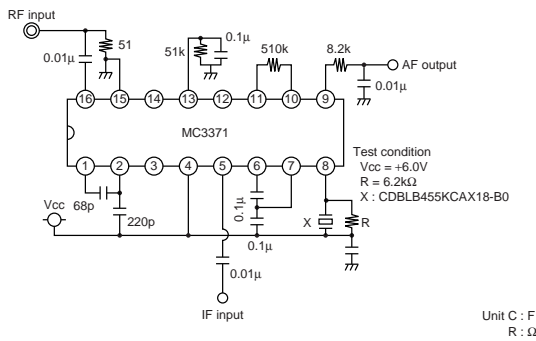

TA31136

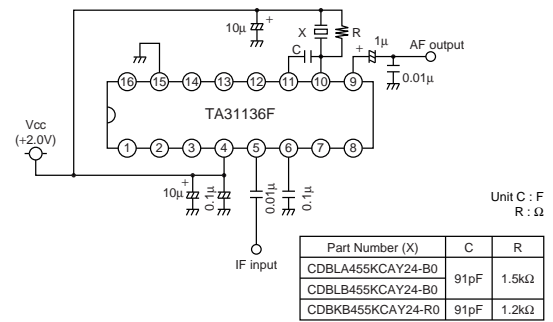

TK10487

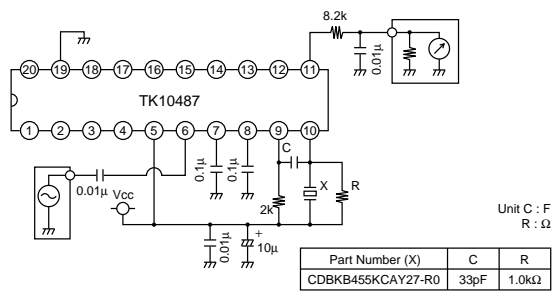

TA31142

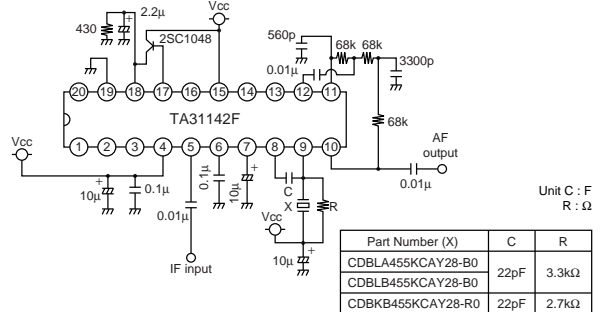

NE605

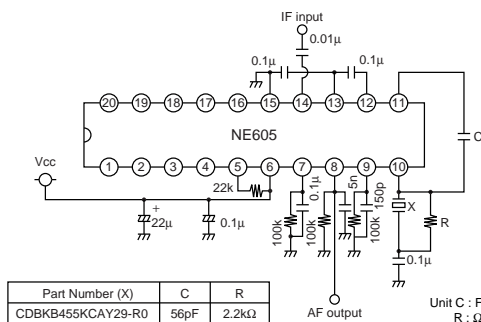

MC13136

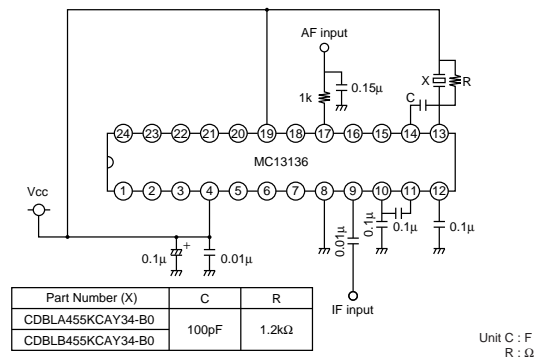

Continued from the preceding page.

Test Circuit

TK10930

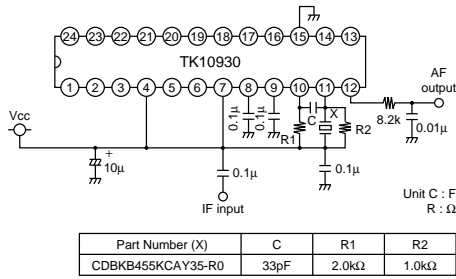

NE(SA)606/616

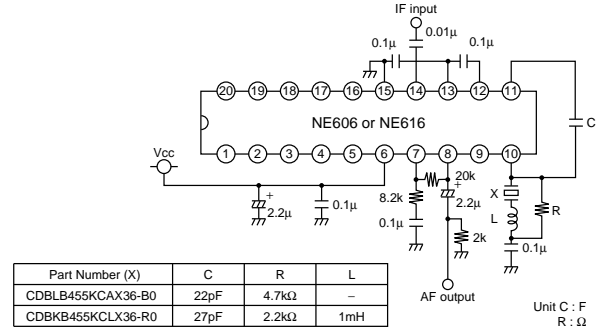

NE(SA)607/617

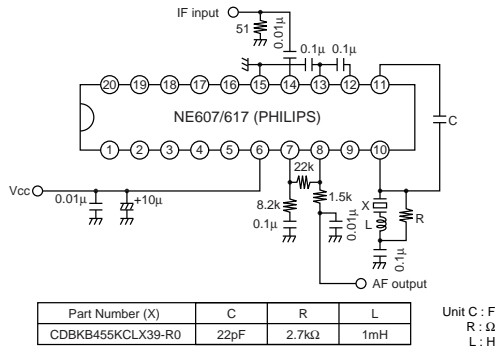

TA31145

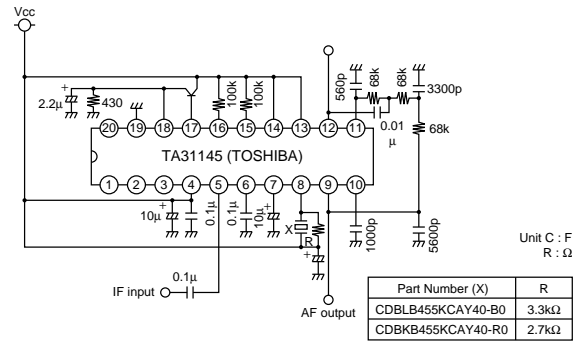

TK14590/14591

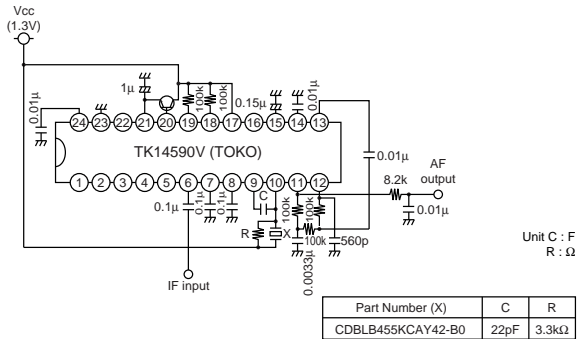

MC3361

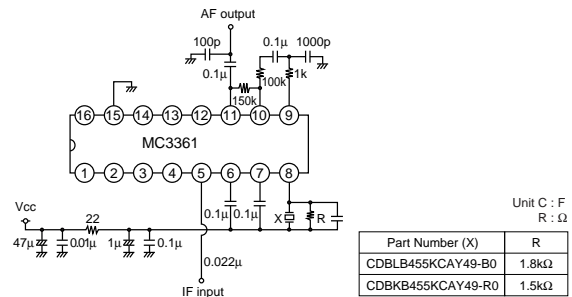

CXA3117

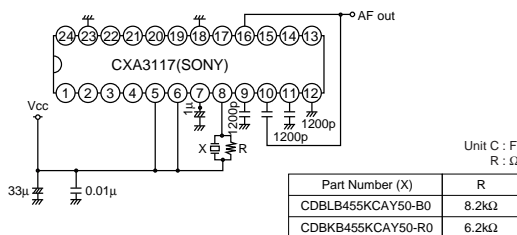

NJM2590

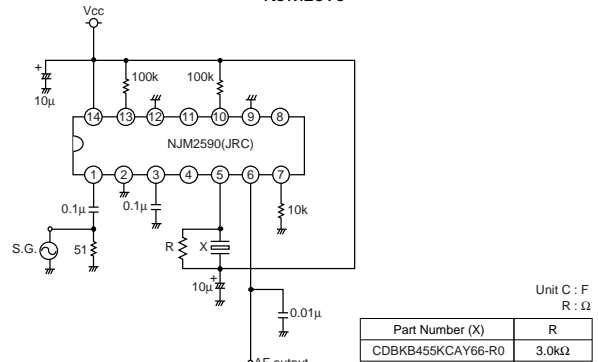



■ Recovered Audio Curve

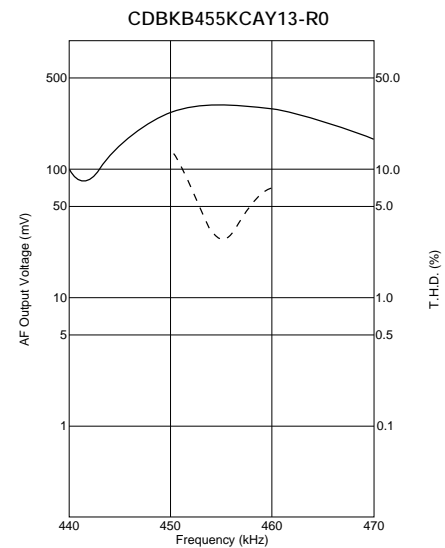
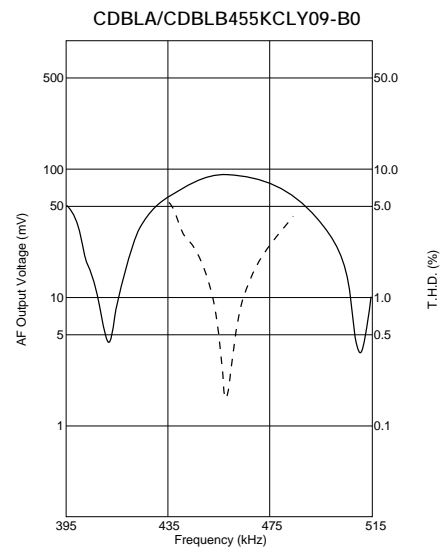
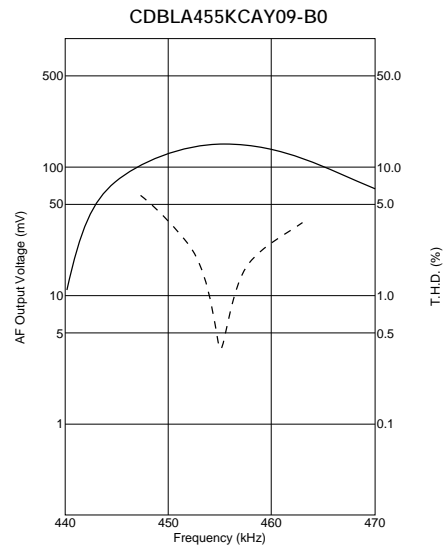
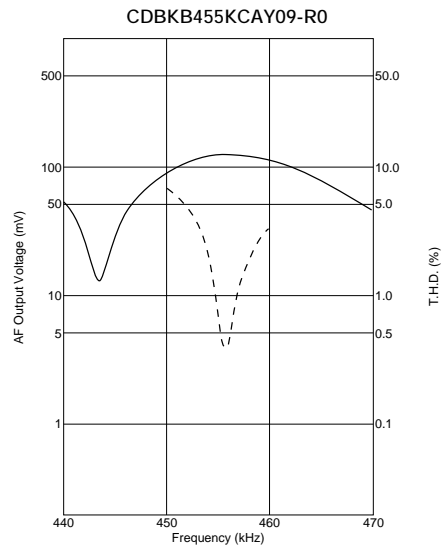
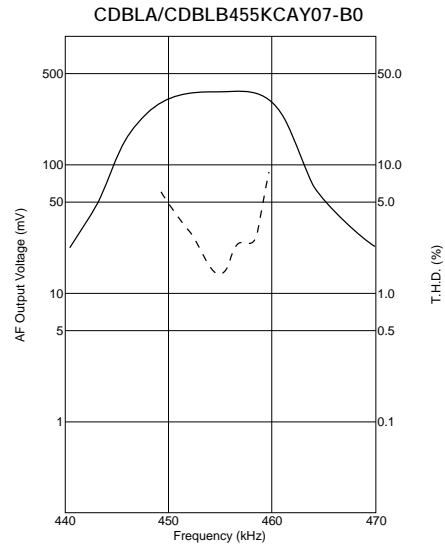
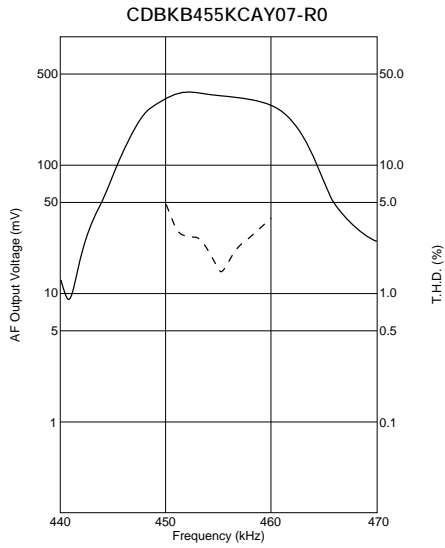

Continued from the preceding page.

Recovered Audio Curve

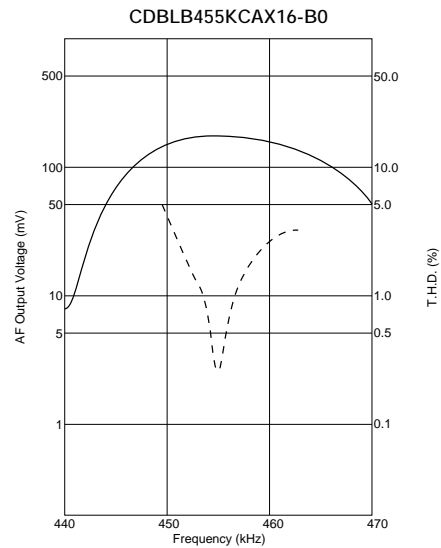
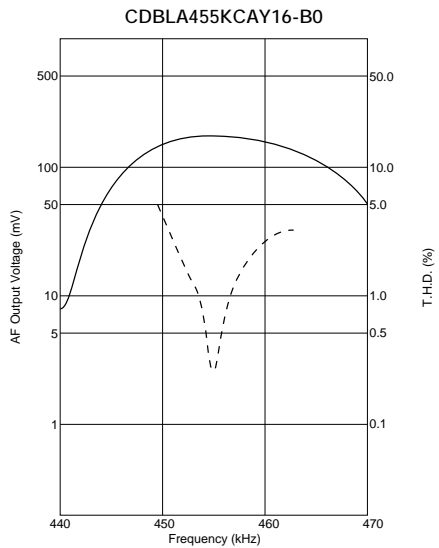
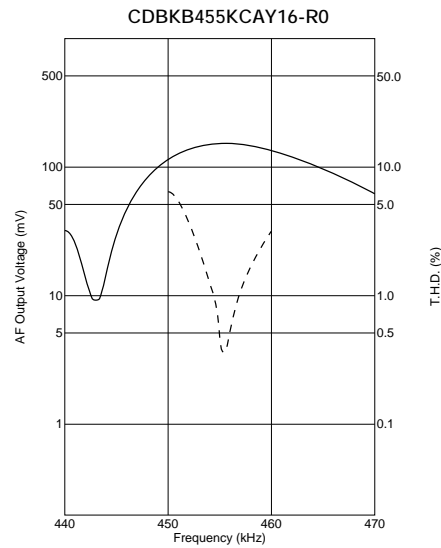
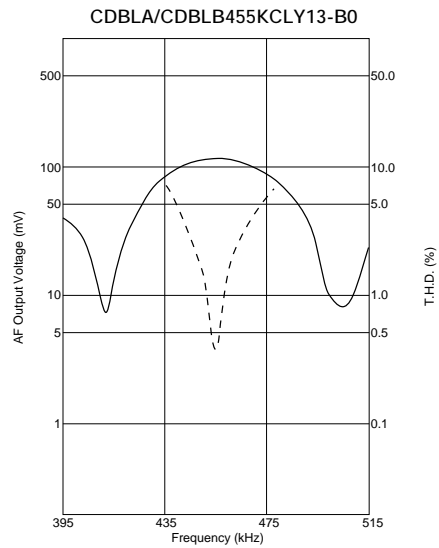
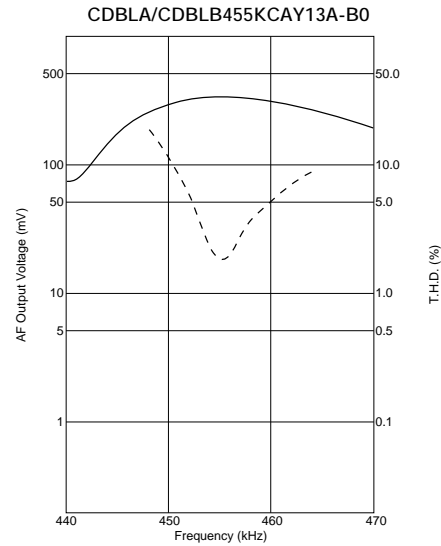
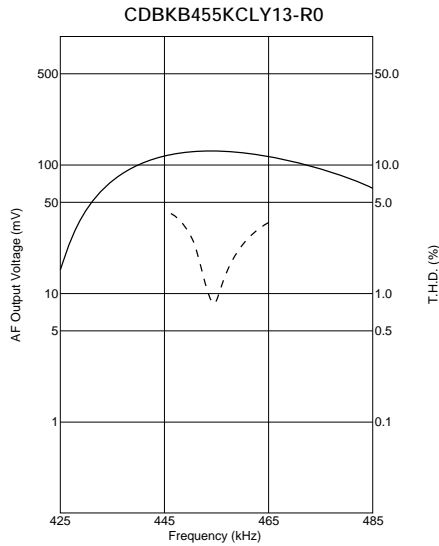

Continued from the preceding page.

Recovered Audio Curve

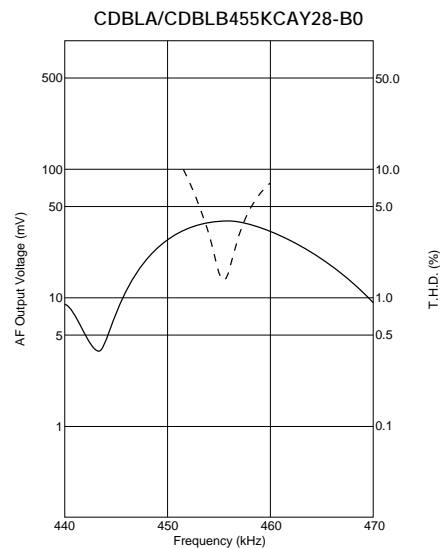
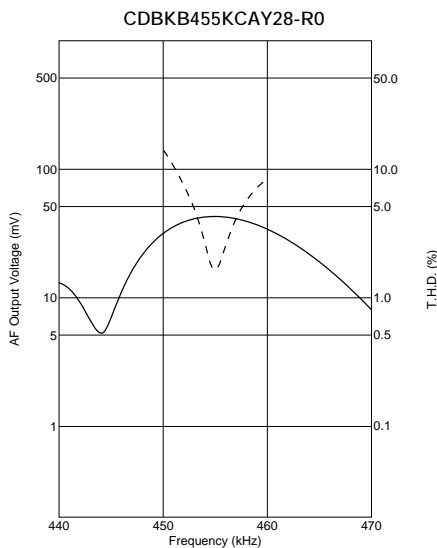
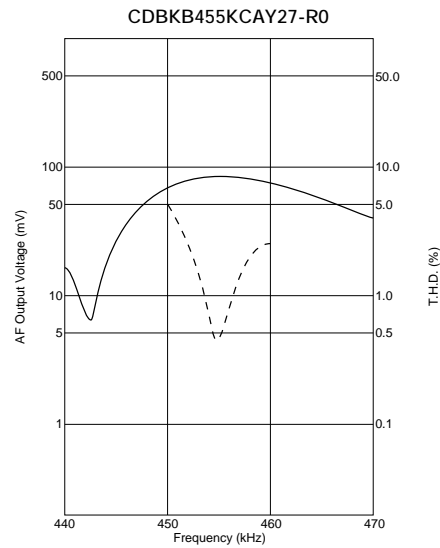
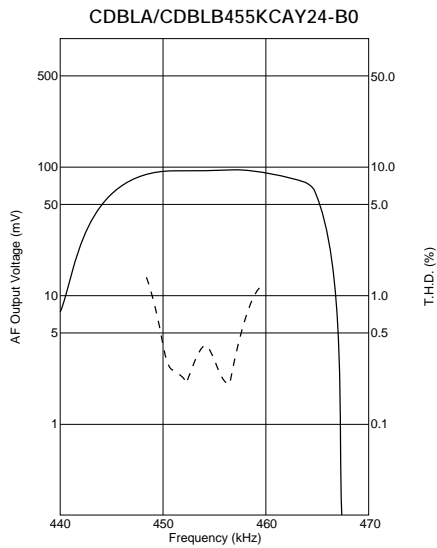
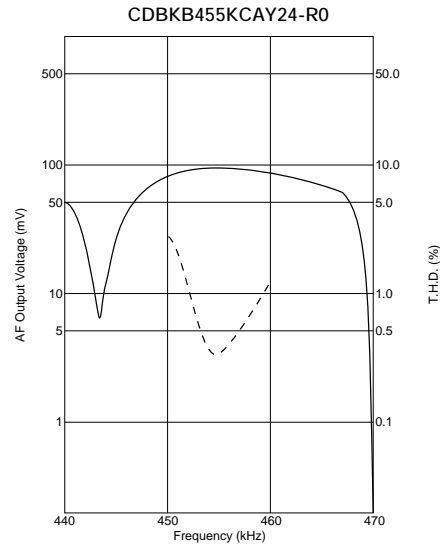
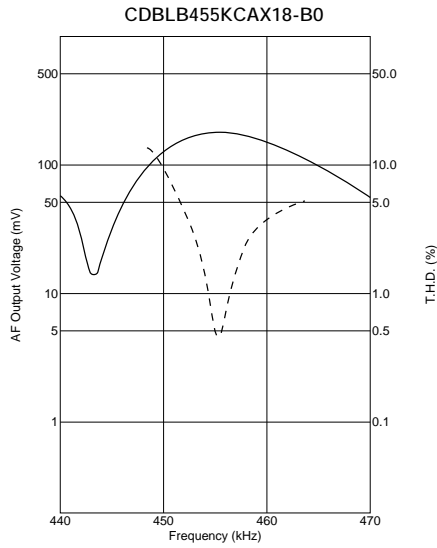

Continued from the preceding page.

Recovered Audio Curve

CDBKB455KCAY29-R0

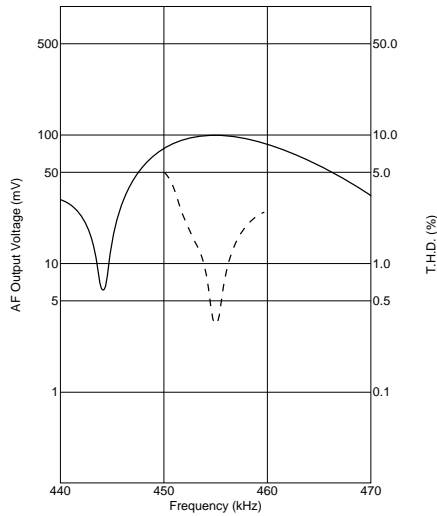

CDBLA/CDBLB455KCAY34-B0

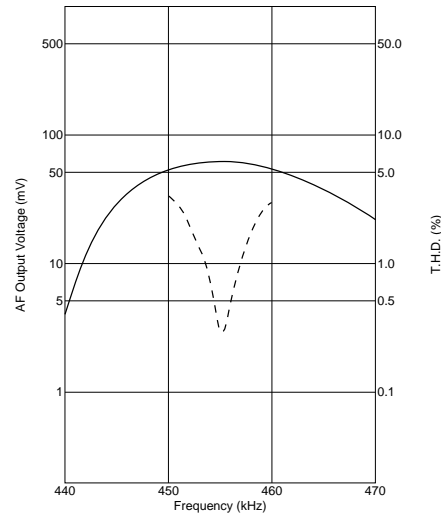

CDBKB455KCAY35-R0

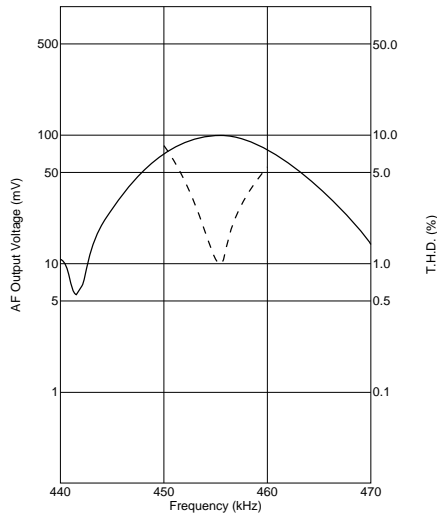

CDBKB455KCLX36-R0

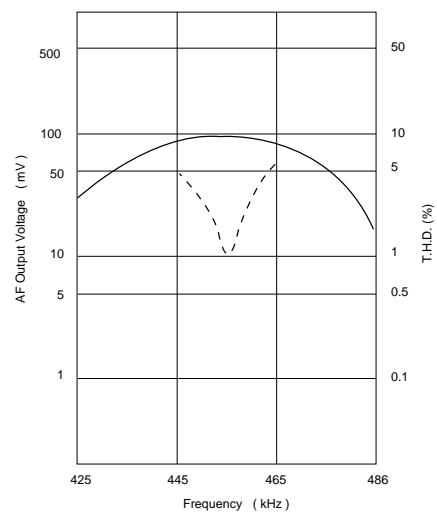

CDBLB455KCAX36-B0

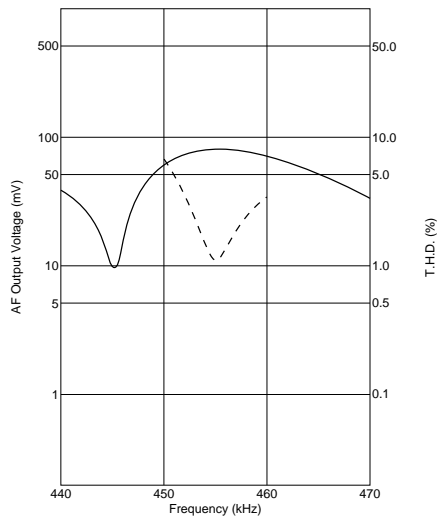

CDBKB455KCLX39-R0

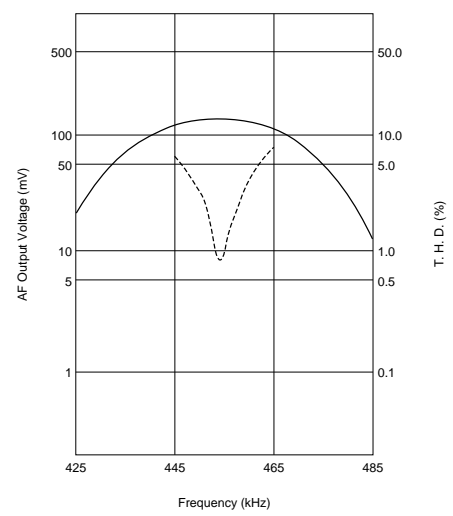

Continued from the preceding page.

Recovered Audio Curve

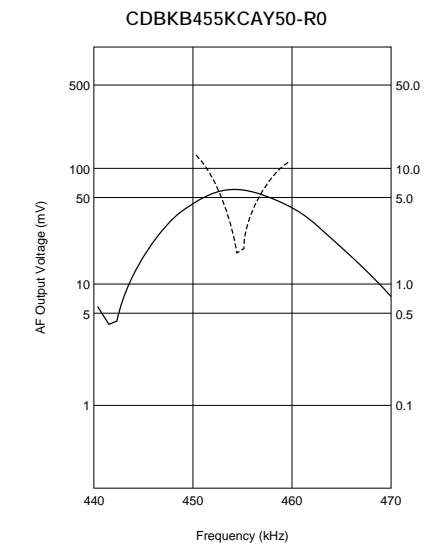
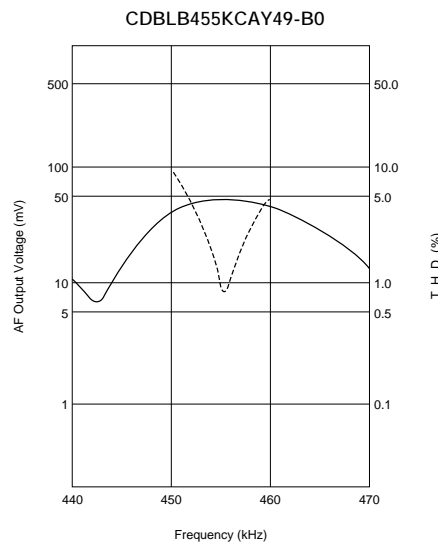
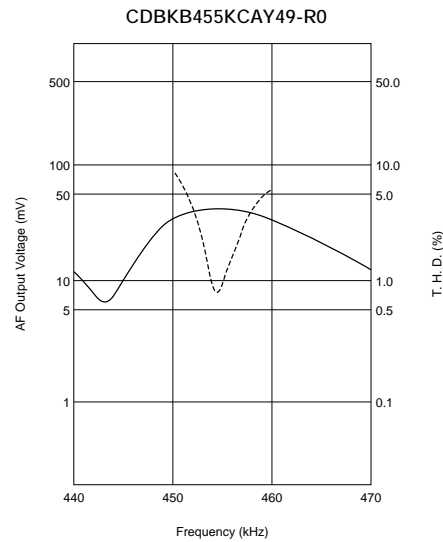
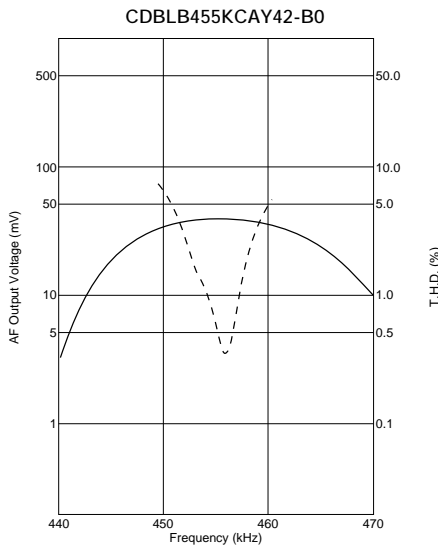
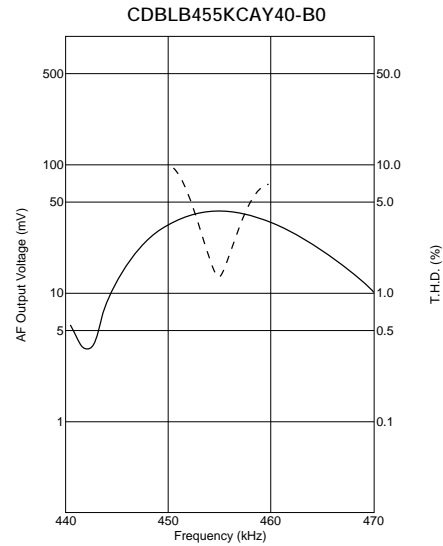
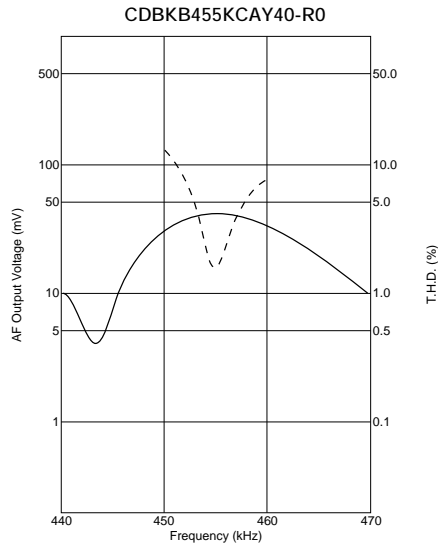

Continued from the preceding page.

### Recovered Audio Curve

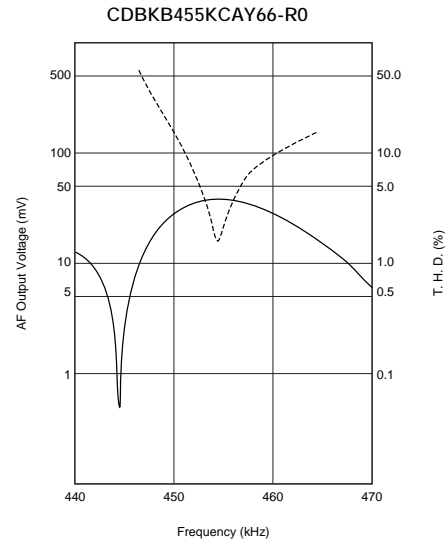
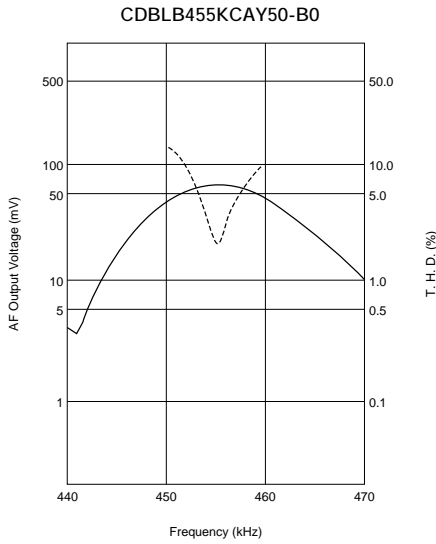

### Specified by S Curve Characteristics

Part Number	Nominal Center Frequency (fm) (kHz)	S Curve (1) Output Volt. at fm (mV)	S Curve (2) at fm±4.8kHz (mV)	IC	IC Maker	Type
CDBKB455KCAY54-R0	455	165 ±20	170 ±20	TA31149	TOSHIBA	SMD

### Test Circuit

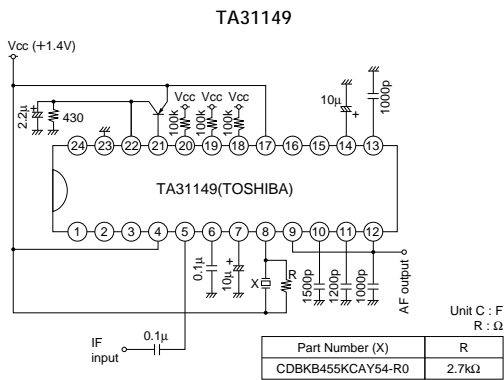

### S Curve

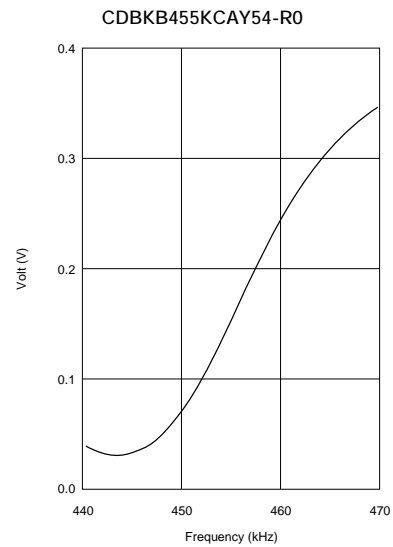

# Ceramic Filters (CERAFIL®)/Ceramic Discriminators for Communications Equipment



## MHz Type Ceramic Discriminators

CDSCB10M7 series forms a resonator on a piezoelectric ceramic substrate. In combination with ICs, this type obtains stable demodulation characteristics in a wide bandwidth.  
 They have 1.0mm max. thickness and small mounting area (4.5x2.0mm).

### ■ Features

1. Compact and high reliability and recommended for automotive applications.
2. Can be combined with various ICs. The IC is determined by the last number in the part number.
3. Stable demodulation characteristics can be obtained without adjustment.
4. Stable temperature characteristics
5. Available lead (Pb) free solder reflow.

CDSCB Series

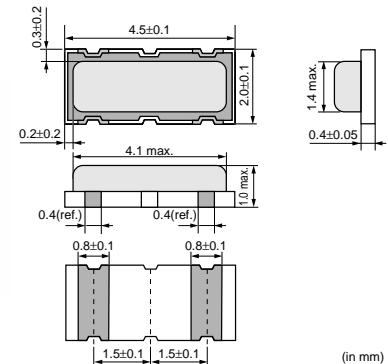

Part Number	Center Frequency (fo) (MHz)	Recovered Audio 3dB BW (kHz)	Recovered Audio Output (mV)	Distortion (%)	S Curve (mV)	IC
CDSCB10M7GA105A-R0	10.700 ±30kHz	220 min.	110 min.	1.5 max.	-	TEA5757HL
CDSCB10M7GA113-R0	10.700 ±30kHz	300 min.	110 min.	1.0 max.	-	TA2154FN
CDSCB10M7GA119-R0	10.700 ±30kHz	500 min.	75 min.	1.0 max.	-	TRF6901
CDSCB10M7GA121-R0	10.700 ±30kHz	390 min.	80 min.	1.0 max.	-	LV23100V
CDSCB10M7GA135-R0	10.700 ±30kHz	155 min.	75 min.	-	-	TH71101
CDSCB10M7GA136-R0	10.700 ±30kHz	140 min.	120 min.	-	-	TH7122
CDSCB10M7GF072-R0	10.700 (fn)	fn±150 min.	130 min.	2.0 max.	-	TA31161
CDSCB10M7GF107S-R0	10.700 (fn)	fn±80 min.	52 min.	3.0 max.	-	TA31272FN
CDSCB10M7GF109-R0	10.700 (fn)	fn±100 min.	170 min.	3.0 max.	-	TK14588V
CDSCB10M7GF123-R0	10.700 (fn)	-	-	-	900 min.	TA31275FN
CDSCB10M7GF123S-R0	10.700 (fn)	-	-	-	900 min.	TA31275FN
CDSCB10M7GF126-R0	10.700 (fn)	-	-	-	400 min.	NJM2295AV

(fn) means nominal center frequency.

The order quantity should be an integral multiple of the "Minimum Quantity" shown in the package page.

For safety purposes, avoid applying a direct current between the terminals.

Test Circuit

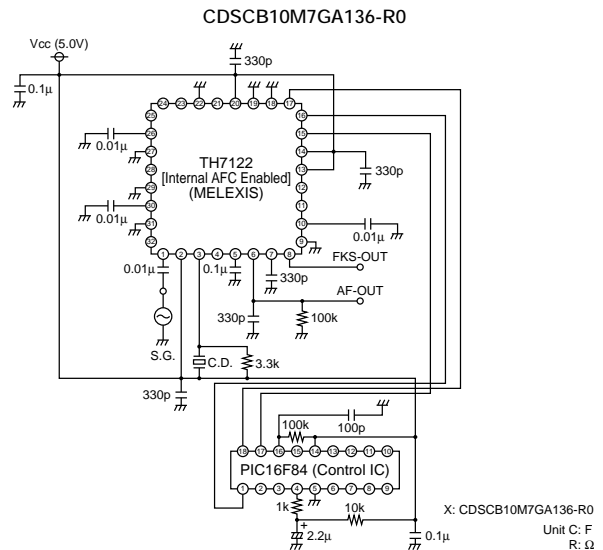
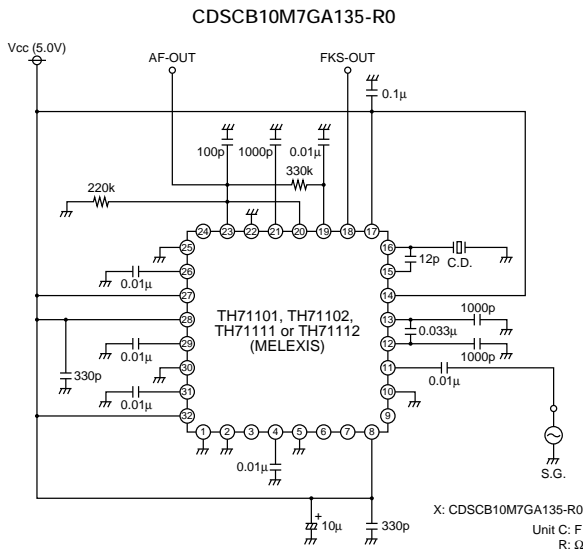
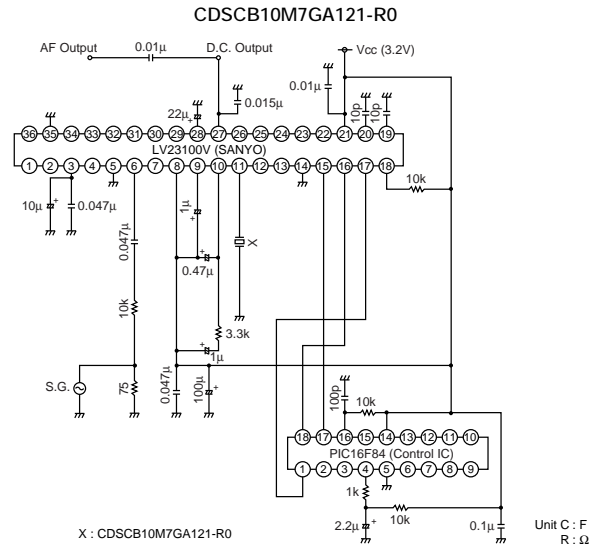
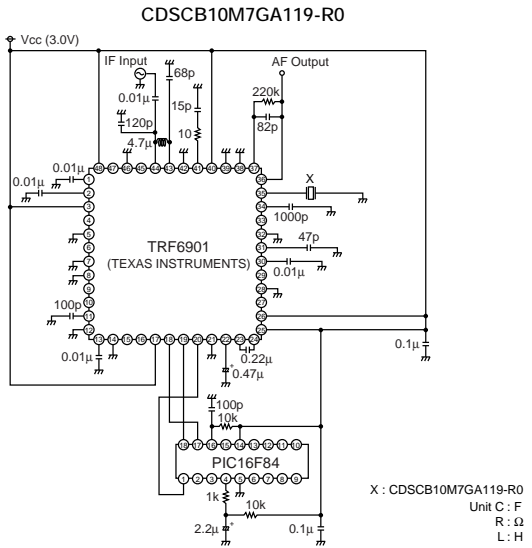
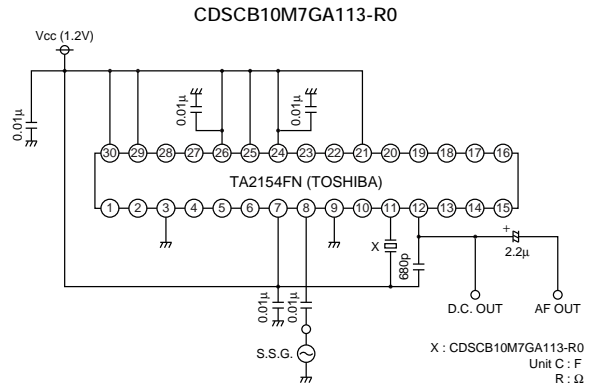
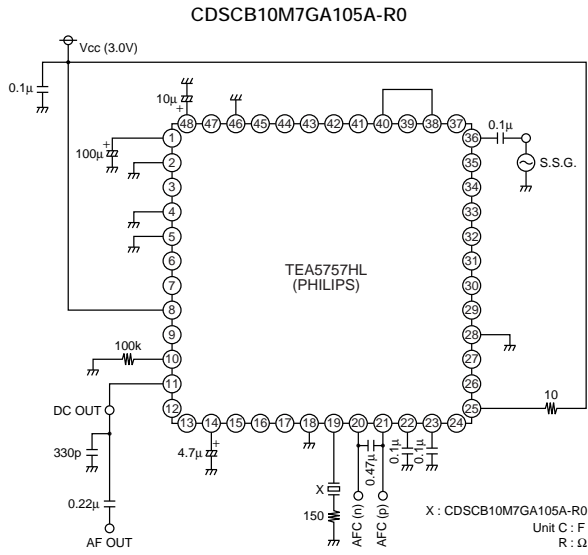



Continued from the preceding page.

Test Circuit

CDSCB10M7GF072-R0

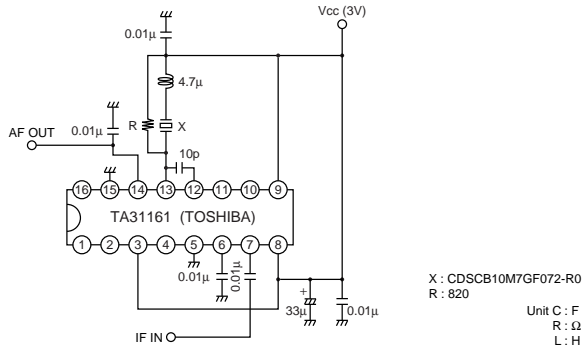

CDSCB10M7GF109-R0

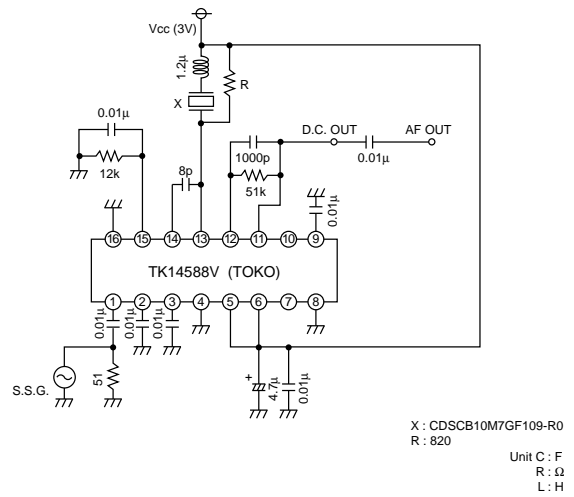

CDSCB10M7GF123-R0

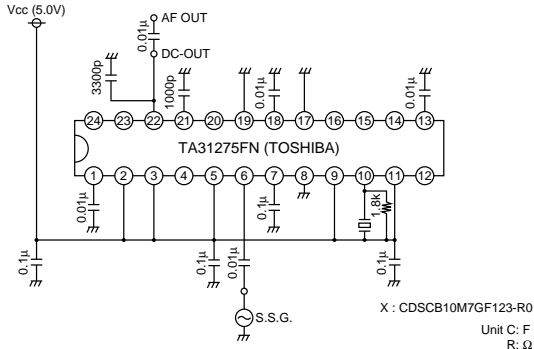

CDSCB10M7GF126-R0

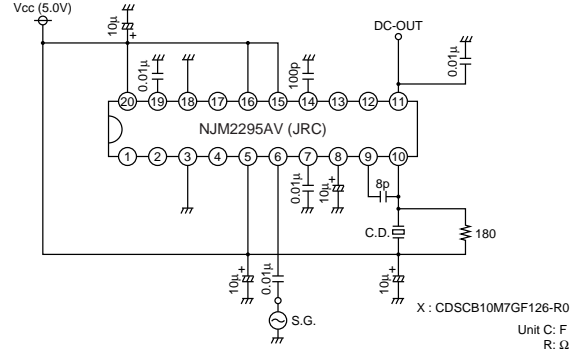

Recovered Audio Curve

CDSCB10M7GA105A-R0

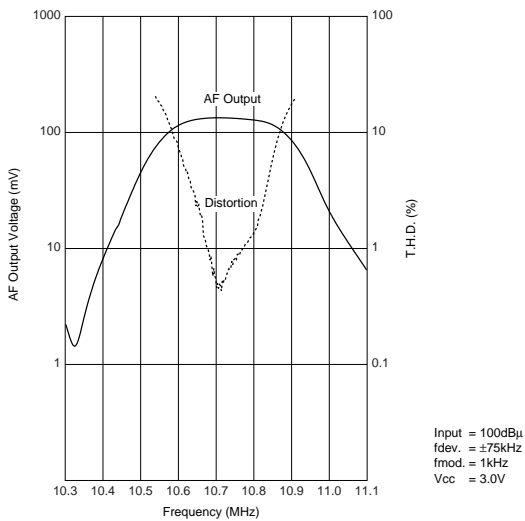

CDSCB10M7GA113-R0

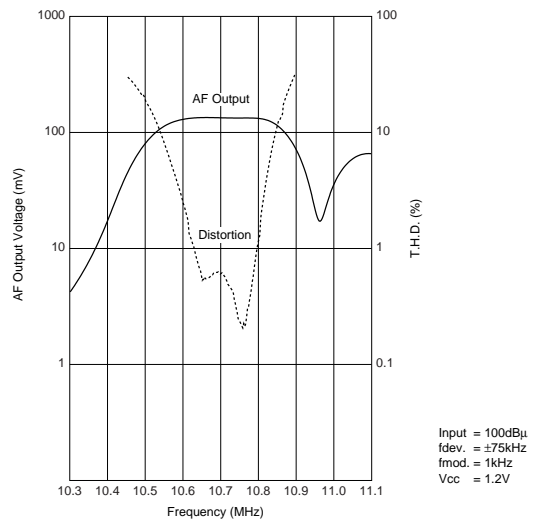

Continued on the following page.

Continued from the preceding page.

### Recovered Audio Curve

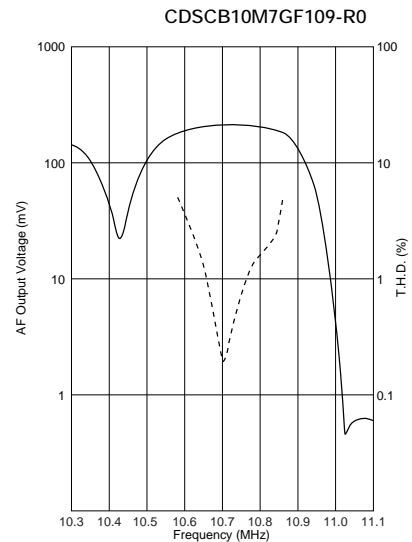
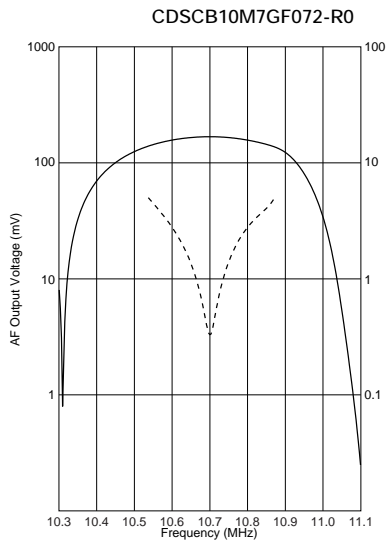
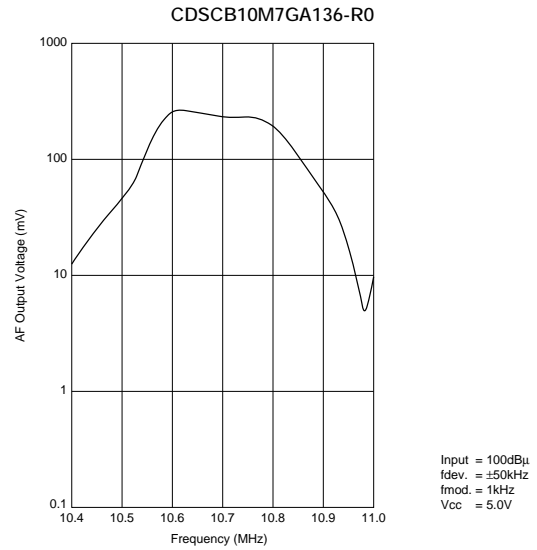
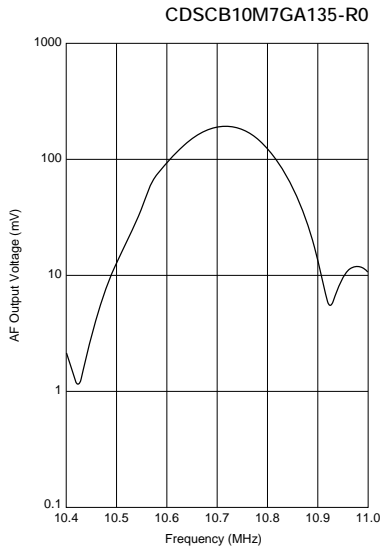
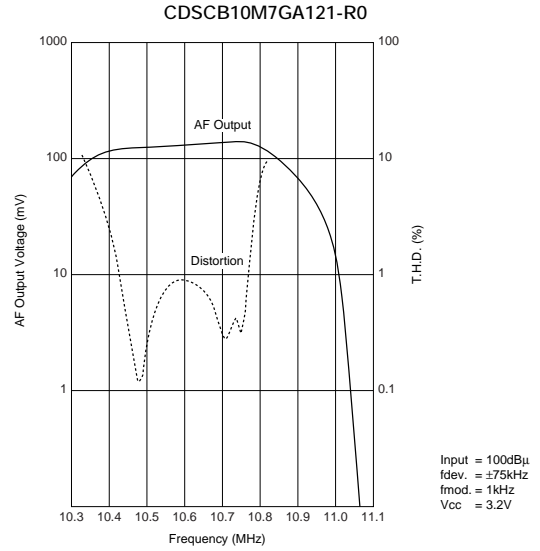
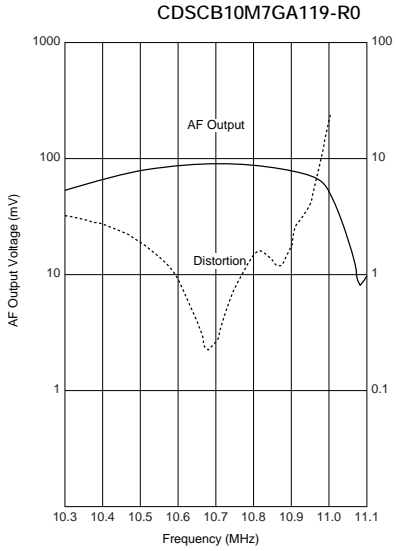

■ S Curve

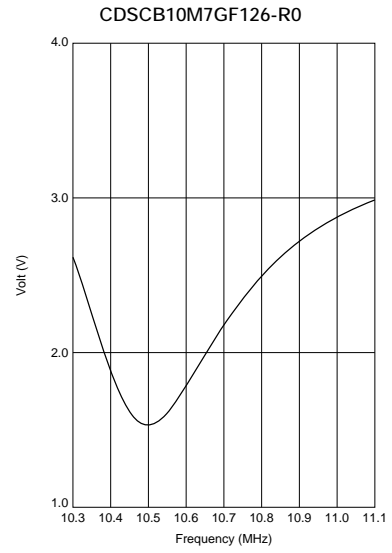
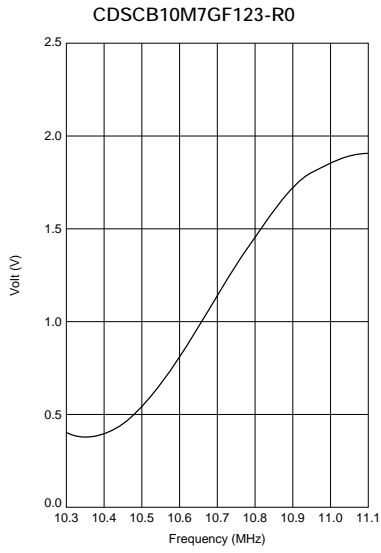

## Ceramic Discriminators Notice

### ■ CDBKB Series Notice (Soldering and Mounting)

#### 1. Standard Reflow Soldering Conditions

##### (1) Reflow

Filter is soldered twice within the following temperature conditions.

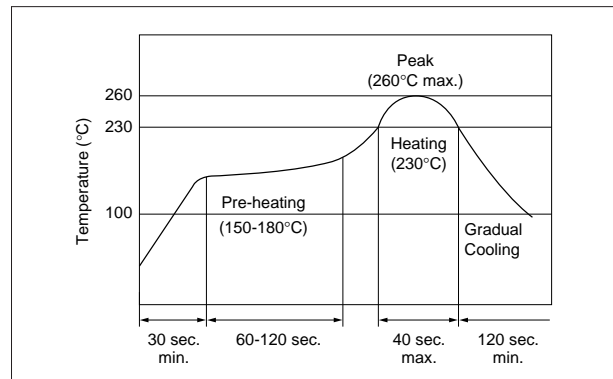

##### (2) Soldering Iron

Electrode is directly soldered with the tip of soldering iron at  $+350\pm 5^{\circ}\text{C}$  for  $3.0\pm 0.5$  seconds.

#### 2. Wash

##### (1) Cleaning Solvent

CFC alternatives (HCFC Series), Isopropyl Alcohol (IPA), Water (Demineralized Water), Cleaning Water Solution (Cleanthrough-750H, Pine Alpha 100S), Silicon (Technocare FRW)

##### (2) Cleaning Conditions

- Immersion Wash  
2 minutes max. in above solvent at  $+60^{\circ}\text{C}$  max.
- Shower or Rinse Wash  
2 minutes max. in above solvent at  $+60^{\circ}\text{C}$  max.

##### (3) Notice

- When components are immersed in solvent, be sure to maintain the temperature of components below the temperature of solvent.
- Please do not use ultrasonic cleaning.
- Total washing time should be within 4 minutes.
- Please ensure the component is thoroughly evaluated in your application circuit.
- Please do not use chlorine, petroleum and alkaline cleaning solvents.
- If you plan to use any other type of solvents, please consult with Murata or Murata representative prior to using.

Continued on the following page. 

## Ceramic Discriminators Notice

Continued from the preceding page.

### ■ CDSCB Series Notice (Soldering and Mounting)

#### 1. Standard Reflow Soldering Conditions

##### (1) Reflow

Filter is soldered twice within the following temperature conditions.

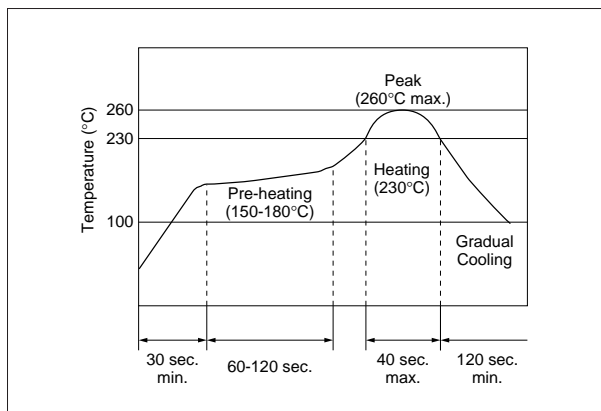

##### (2) Soldering Iron

Filter is soldered at  $+300\pm 5^{\circ}\text{C}$  for  $3.0\pm 0.5$  seconds. The soldering iron should not touch the filter while soldering.

#### 2. Wash

The component cannot withstand washing.

## Ceramic Discriminators Notice

### ■ CDBKB Series Notice (Handling)

1. The component will be damaged when an excessive stress is applied.
2. In the case that the component is cleaned, confirm no reliability degradation is created.
3. In case of covering filter with over coat, conditions such as material of resin, cure temperature, and so on should be evaluated carefully.
4. Do not use strong acidity flux, more than 0.2wt% chlorine content, in re-flow soldering.

### ■ CDBLA/CDBLB Series Notice (Handling)

1. Do not use this product with bend. The component may be damaged if excess mechanical stress is applied to it mounted on the printed circuit board.
2. The component will be damaged when an excessive stress is applied.
3. All kinds of re-flow soldering must not be applied on the component.

### ■ CDSCB Series Notice (Handling)

1. The component mounted on the PCB may be damaged if excessive mechanical stress is applied.
2. Layout the components on the PCB to minimize the stress imposed on the warp or flexure of the board.
3. After installing components, if solder is excessively applied to the circuit board, mechanical stress will cause destruction resistance characteristics to lower. To prevent this, be extremely careful in determining shape and dimension before designing the circuit board diagram.
4. The component may be damaged during mounting process if some part of mounter such as positioning claws or nozzle are worn down. The regular maintenance recommended for mounters should be done to prevent troubles.
5. When correcting component's position with a soldering iron, the tip of the soldering iron should not directly touch the chip component. Depending on the soldering conditions, the effective area of terminations may be reduced. The use of solder containing Ag should be considered to prevent the electrode erosion.
6. Do not clean or wash the component as it is not hermetically sealed.
7. In case of overcoating the part, coating conditions such as material of resin, curing temperature, and so on should be evaluated carefully.
8. Accurate test circuit values are required to measure electrical characteristics.  
It may be a cause of miscorrelation if there is any deviation, especially stray capacitance, from the test circuit in the specification.
9. For safety purposes, avoid applying a direct current between the terminals.

5. The product, packed in the moisture-proof bag (dry pack), is sensitive to moisture.  
The following treatment is required before applying re-flow soldering, to avoid package cracks or reliability degradation caused by thermal stress. When unpacked, store the component in an atmosphere of below 25 degrees C. and below 65%R.H., and solder within 48 hours.

4. Do not clean or wash the component as it is not hermetically sealed.
5. Do not use strong acidity flux, more than 0.2wt% chlorine content, in flow soldering.
6. In case of covering discriminator with over coat, conditions such as material of resin, cure temperature, and so on should be evaluated carefully.

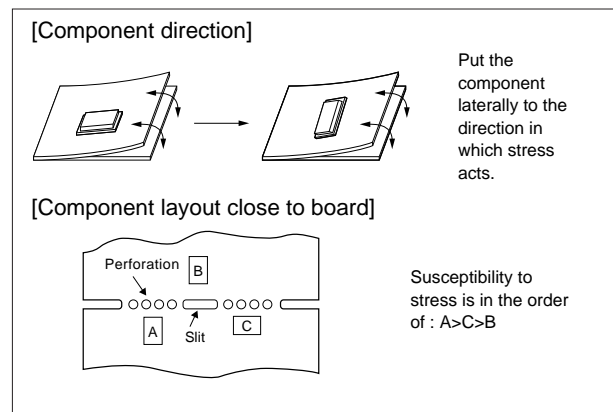

# Ceramic Discriminators Standard Land Pattern Dimensions/Packaging

## Standard Land Pattern Dimensions

CDBKB Series

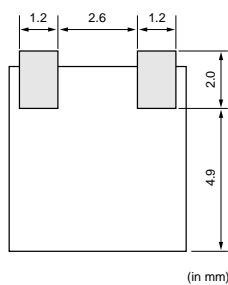

CDSCB Series

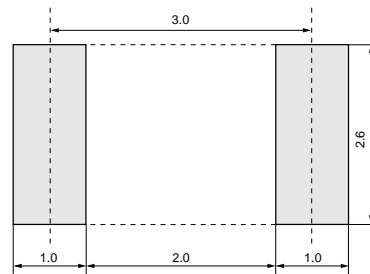

## Minimum Quantity

Part Number	Taping $\phi 180\text{mm}$	Bulk	Magazine
CDBKB Series	500		
CDBLA Series		500	50
CDBLB Series		500	80
CDSCB Series	2000		

The order quantity should be an integral multiple of the "Minimum Quantity" shown above.

(pcs.)

## CDBKB Series

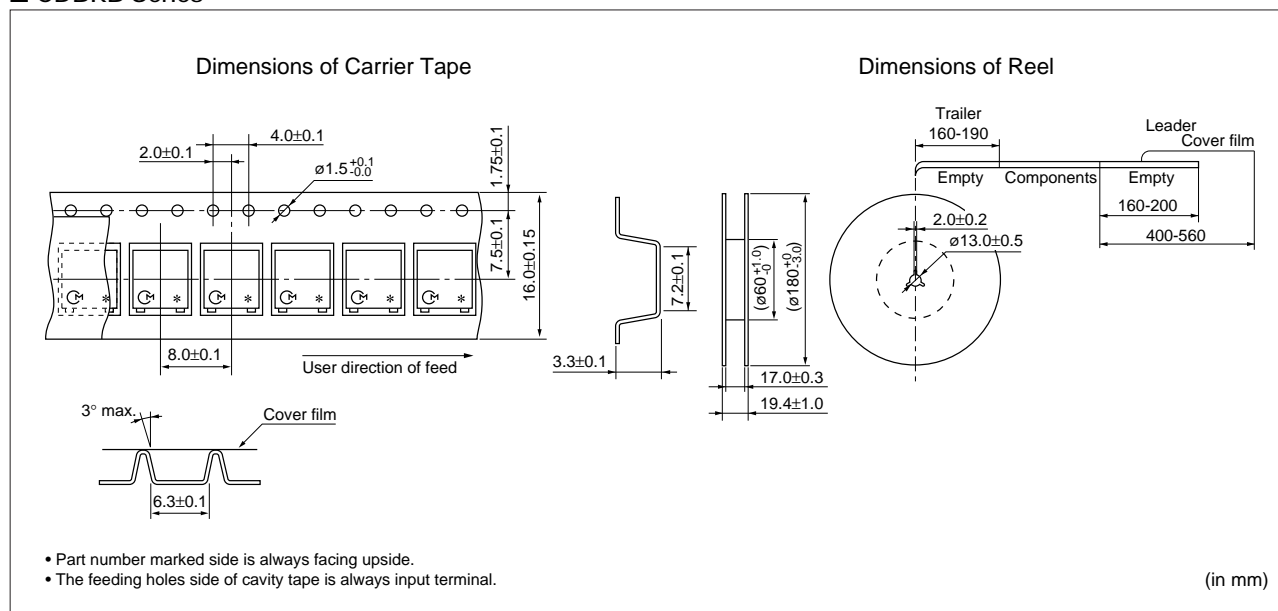

Continued on the following page.

## Ceramic Discriminators Standard Land Pattern Dimensions/Packaging

Continued from the preceding page.

### CDSCB Series

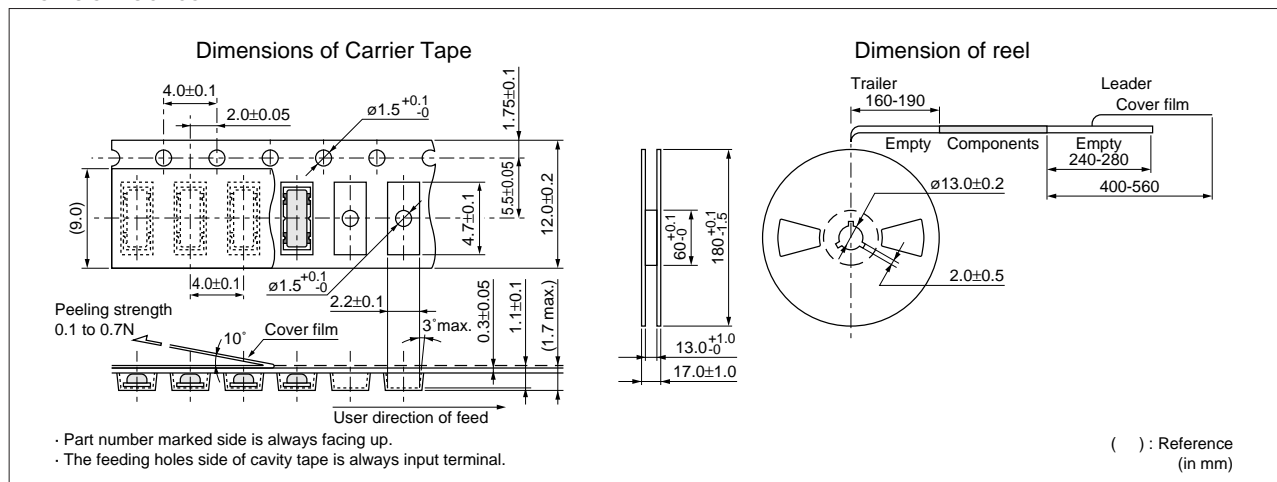



⚠Note:

1. Export Control

<For customers outside Japan>

No muRata products should be used or sold, through any channels, for use in the design, development, production, utilization, maintenance or operation of, or otherwise contribution to (1) any weapons (Weapons of Mass Destruction [nuclear, chemical or biological weapons or missiles] or conventional weapons) or (2) goods or systems specially designed or intended for military end-use or utilization by military end-users.

<For customers in Japan>

For products which are controlled items subject to the "Foreign Exchange and Foreign Trade Law" of Japan, the export license specified by the law is required for export.

2. Please contact our sales representatives or product engineers before using the products in this catalog for the applications listed below, which require especially high reliability for the prevention of defects which might directly damage a third party's life, body or property, or when one of our products is intended for use in applications other than those specified in this catalog.

- |                             |  |
|-----------------------------|--|
| ① Aircraft equipment        | ② Aerospace equipment  |
| ③ Undersea equipment        | ④ Power plant equipment  |
| ⑤ Medical equipment         | ⑥ Transportation equipment (vehicles, trains, ships, etc.)   |
| ⑦ Traffic signal equipment  | ⑧ Disaster prevention / crime prevention equipment   |
| ⑨ Data-processing equipment | ⑩ Application of similar complexity and/or reliability requirements to the applications listed above |

3. Product specifications in this catalog are as of September 2007. They are subject to change or our products in it may be discontinued without advance notice. Please check with our sales representatives or product engineers before ordering. If there are any questions, please contact our sales representatives or product engineers.

4. Please read rating and ⚠ CAUTION (for storage, operating, rating, soldering, mounting and handling) in this catalog to prevent smoking and/or burning, etc.

5. This catalog has only typical specifications because there is no space for detailed specifications. Therefore, please approve our product specifications or transact the approval sheet for product specifications before ordering.

6. Please note that unless otherwise specified, we shall assume no responsibility whatsoever for any conflict or dispute that may occur in connection with the effect of our and/or a third party's intellectual property rights and other related rights in consideration of your use of our products and/or information described or contained in our catalogs. In this connection, no representation shall be made to the effect that any third parties are authorized to use the rights mentioned above under licenses without our consent.

7. No ozone depleting substances (ODS) under the Montreal Protocol are used in our manufacturing process.



<http://www.murata.com/>

**Head Office**  
1-10-1, Higashi Kotari, Nagaokakyo-shi, Kyoto 617-8555, Japan  
Phone: 81-75-951-9111

**International Division**  
3-29-12, Shibuya, Shibuya-ku, Tokyo 150-0002, Japan  
Phone: 81-3-5469-6123 Fax: 81-3-5469-6155 E-mail: [intl@murata.co.jp](mailto:intl@murata.co.jp)