

# CERAFIL® (Filters/Traps/Discriminators) for Audio/Visual Equipment



## Ceramic Discriminator 10.7MHz Standard Lead Type CDALA Series

CDALA10M7 series forms a resonator on a piezoelectric ceramic substrate. In combination with ICs, this type obtains stable demodulation characteristics in wide bandwidths.

### ■ Features

1. Compact and excellent mechanical strength
2. Can be combined with various ICs. The IC is determined by the last number in the part number.
3. Stable demodulation characteristics can be obtained without adjustment.
4. Stable temperature characteristics
5. We recommend combination: ceramic discriminator CDALA10M7 series and "CERAFIL" SFELA10M7 of the same frequency rank.

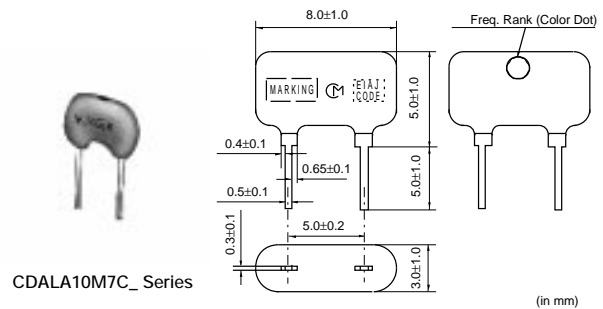
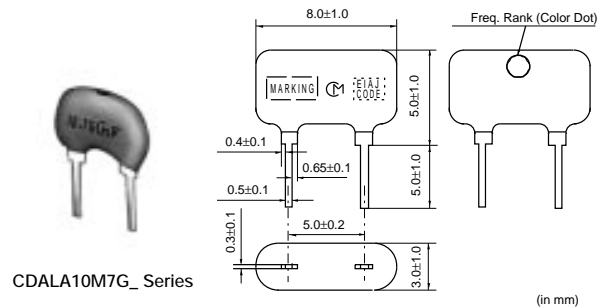

Part Number	Center Frequency (fo) (MHz)	Recovered Audio 3dB BW (kHz)	Recovered Audio Output (mV)	Distortion (%)	IC	Detection Method
CDALA10M7GA001-B0	10.700 ±30kHz	-	-	0.6 max.	CX20029	Quadrature
CDALA10M7GA016-B0	10.700 ±30kHz	300 min.	within60 to 90mV	0.9 max.	TA8122F	Quadrature
CDALA10M7GA018-B0	10.700 ±30kHz	300 min.	within60 to 90mV	0.9 max.	TA8132N	Quadrature
CDALA10M7GA046-B0	10.700 ±30kHz	330 min.	280 min.	1.0 max.	LA1832	Quadrature
CDALA10M7GA048-B0	10.700 ±30kHz	400 min.	700 min.	1.0 max.	LA1835	Quadrature
CDALA10M7GA092-B0	10.700 ±30kHz	300 min.	60 min.	1.0 max.	TA2132P	Quadrature
CDALA10M7CA001-B0	10.700 ±30kHz	242 min.	35 min.	1.0 max.	CX20091	Quadrature
CDALA10M7CA005A-B0	10.700 ±30kHz	100 min.	600 min.	6.0 max.	LA7770	Quadrature
CDALA10M7CA040-B0	10.700 ±30kHz	130 min.	40 min.	0.7 max.	TEA5710	Quadrature

The order quantity should be an integral multiple of the "Minimum Quantity" shown in the package page.  
CDALA10M7GA018-B0: Color dot is different from standard series.

### ■ Standard Center Frequency Rank Code

CODE	30kHz Step	25kHz Step	Color Code
D	10.64MHz±30kHz	10.650MHz±25kHz	Black
B	10.67MHz±30kHz	10.675MHz±25kHz	Blue
A	10.70MHz±30kHz	10.700MHz±25kHz	Red
C	10.73MHz±30kHz	10.725MHz±25kHz	Orange
E	10.76MHz±30kHz	10.750MHz±25kHz	White
Z	Combination A,B,C,D,E		
M	Combination A,B,C		

■ Test Circuit

CDALA10M7GA001-B0

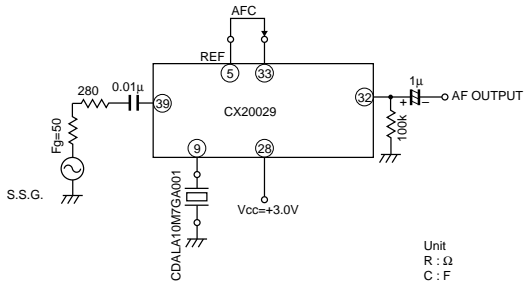

Unit  
R : Ω  
C : F

CDALA10M7GA016-B0

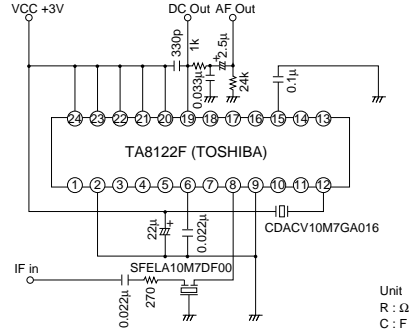

Unit  
R : Ω  
C : F

CDALA10M7GA018-B0

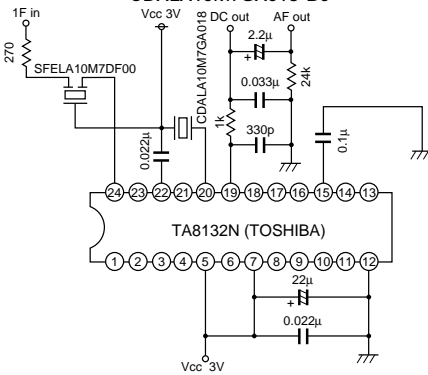

Unit  
R : Ω  
C : F

CDALA10M7GA046-B0

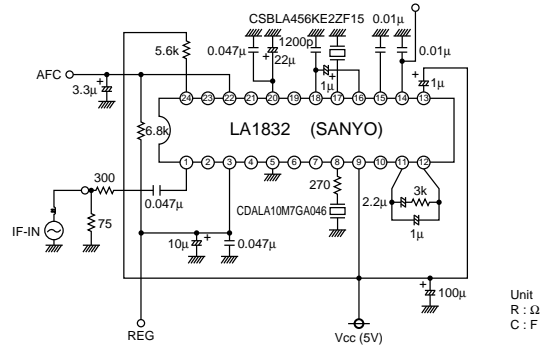

Unit  
R : Ω  
C : F

CDALA10M7GA048-B0

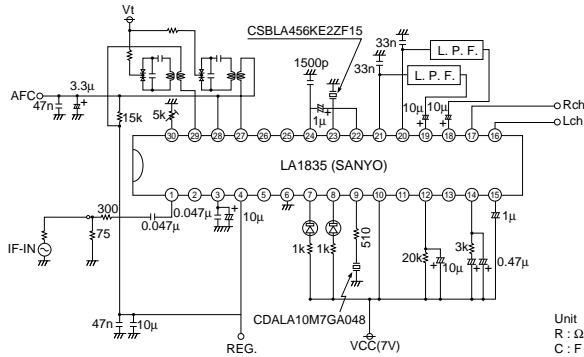

Unit  
R : Ω  
C : F

CDALA10M7GA092-B0

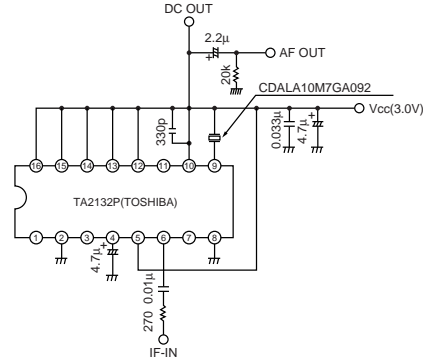

Unit  
R : Ω  
C : F

CDALA10M7CA001-B0

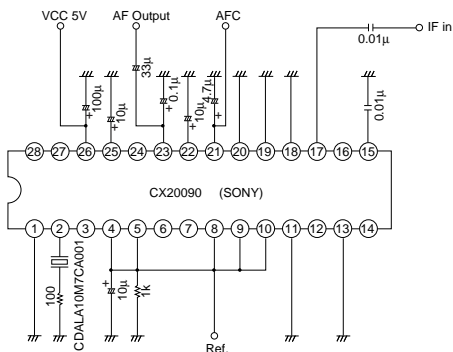

Unit  
R : Ω  
C : F

CDALA10M7CA005A-B0

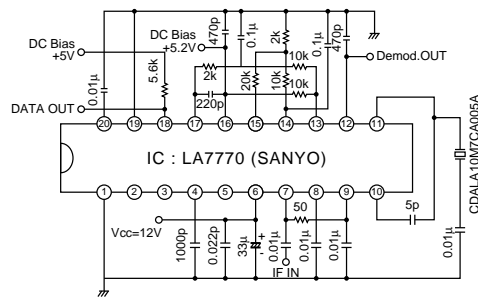

Unit  
R : Ω  
C : F

Continued on the following page. ⌘

Continued from the preceding page.

### Test Circuit

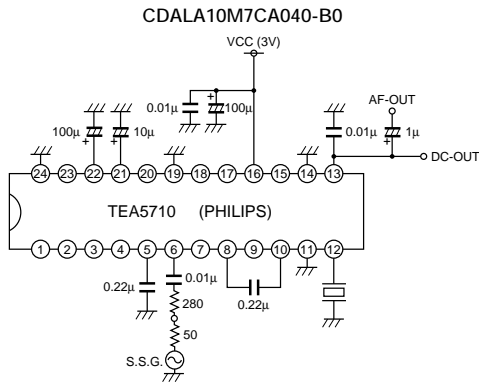

Unit  
R : Ω  
C : F

### Frequency Characteristics

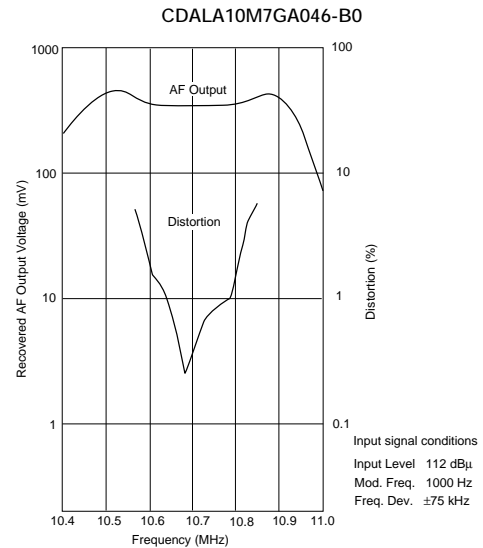
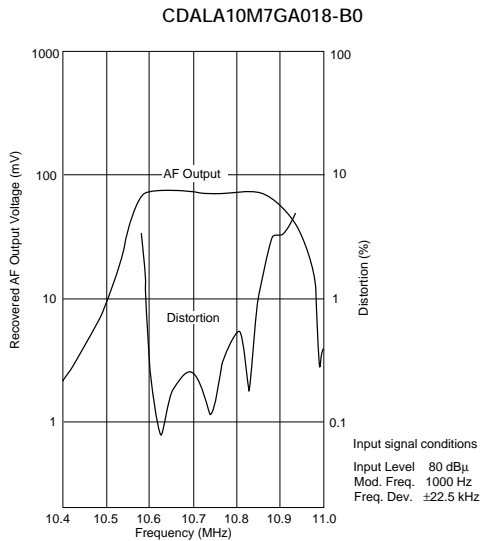
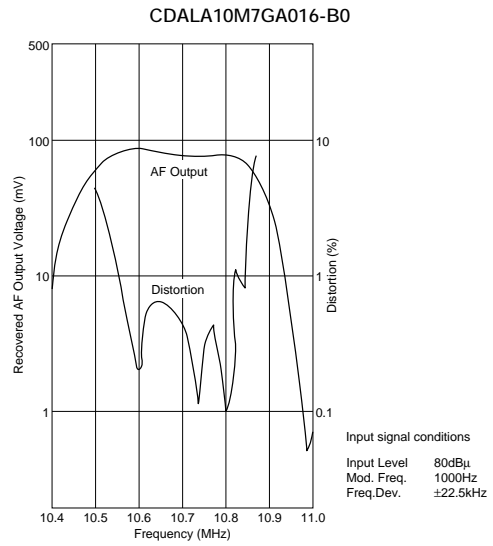
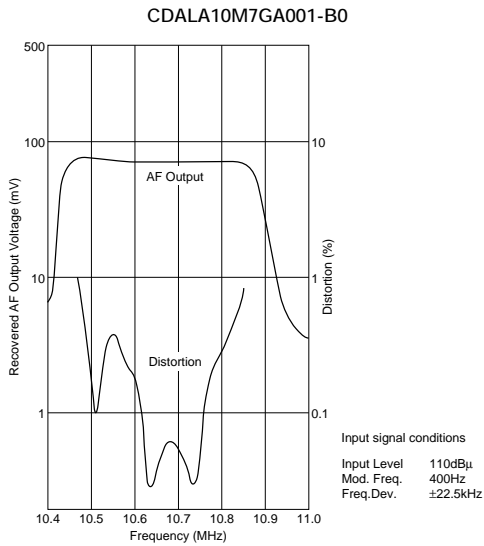

31

Continued on the following page.

Continued from the preceding page.

## Frequency Characteristics

CDALA10M7GA048-B0

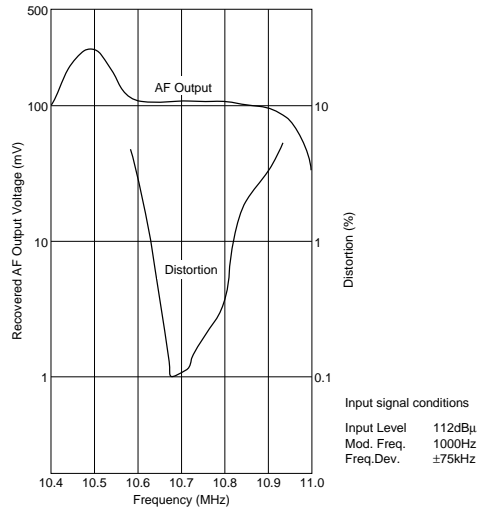

CDALA10M7GA092-B0

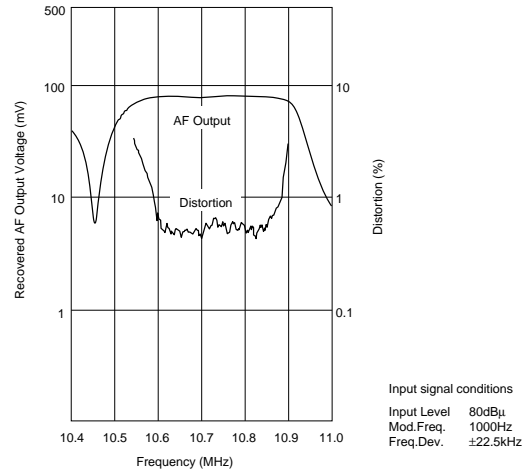

CDALA10M7CA001-B0

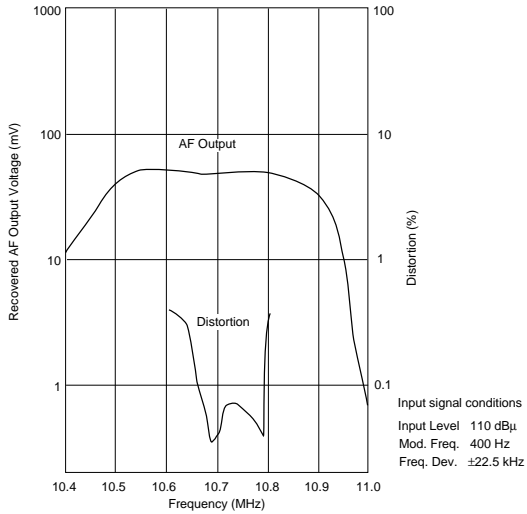

CDALA10M7CA005A-B0

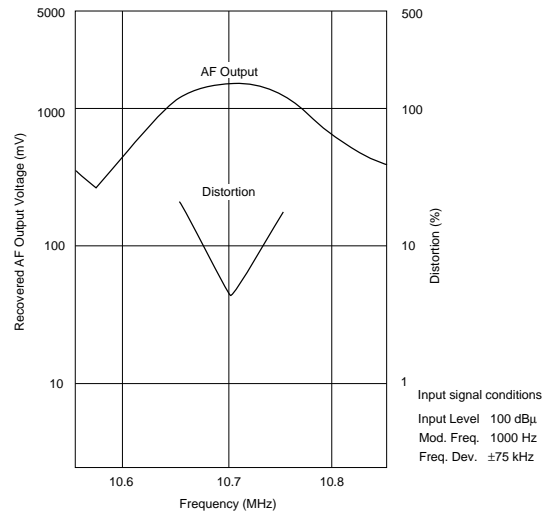

CDALA10M7CA040-B0

