



RM Cores

Series/Type: **RM 6**

The following products presented in this data sheet are being withdrawn.

Ordering Code	Substitute Product	Date of Withdrawal	Deadline Last Orders	Last Shipments
B65808N1005D002	B65808N1006D002	2003-08-08	2004-02-29	2004-08-31
B65659F0001X101	B65659F0001X023	2004-01-23		
B65821C1008T002	B65821C1008T001	2003-08-08	2004-02-29	2004-08-31
B65807C0000R026	B65807C0000R048	2002-08-02	2002-12-31	2003-03-31
B65807J0000Y042	B65807J0000Y066	2002-08-02	2002-12-31	2003-03-31
B65808K1006D002	B65808N1006D002	2003-08-08	2004-02-29	2004-08-31

For further information please contact your nearest EPCOS sales office, which will also support you in selecting a suitable substitute. The addresses of our worldwide sales network are presented at www.epcos.com/sales.

RM 6
Core
B65807

- In accordance with IEC 60431
- Core without center hole for transformer applications
- RM cores are supplied in sets

Magnetic characteristics (per set)

	with center hole	without center hole	
$\Sigma I/A$	0,86	0,78	mm ⁻¹
l_e	26,9	28,6	mm
A_e	31,3	36,6	mm ²
A_{min}	—	31	mm ²
V_e	840	1 050	mm ³

Approx. weight (per set)

m	4,9	5,3	g

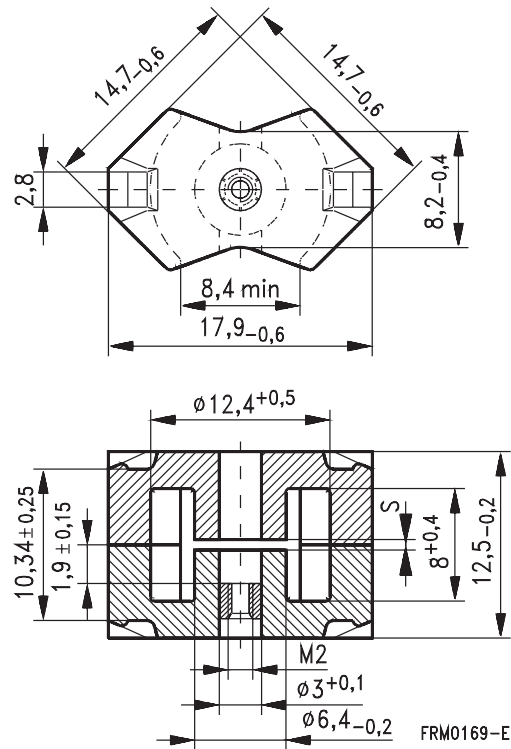
Gapped

Material	A_L value nH	s approx. mm	μ_e	Ordering code ¹⁾ -J without center hole -N with threaded sleeve -C with center hole
K1	40 ± 3 %	0,80	27,4	B65807-+40-A1
M33	63 ± 3 %	0,60	43,2	B65807-+63-A33
	100 ± 3 %	0,38	68,5	B65807-+100-A33
N48	160 ± 3 %	0,22	110	B65807-+160-A48
	250 ± 3 %	0,12	171	B65807-+250-A48
	315 ± 3 %	0,08	216	B65807-+315-A48
	400 ± 3 %	0,05	274	B65807-+400-A48
N41	250 ± 3 %	0,17	155	B65807-J250-A41

1) Replace the + by the code letter "C" or "N" for the required version. Standard version is "C".

Ungapped

Material	A_L value nH	μ_e	A_{L1min} nH	P_V W/set	Ordering code -C with center hole -J w/o center hole
N26	2200 + 30/- 20 %	1500			B65807-C-R26
N30	4300 + 30/- 20 %	2670			B65807-J-R30
T57 ¹⁾	3500 + 30/- 20 %	2180			B65807-J-R57
T38	8600 + 40/- 30 %	5340			B65807-J-Y38
T42	12300 + 40/- 30 %	7630			B65807-J-Y42
N49	1700 + 30/- 20 %	1060	960	< 0,15 (50 mT, 500 kHz, 100 °C)	B65807-J-R49
N87	2400 + 30/- 20 %	1490	1450	< 0,51 (200 mT, 100 kHz, 100 °C)	B65807-J-R87
N97 ¹⁾	2400 + 30/- 20 %	1490	1450	< 0,39 (200 mT, 100 kHz, 100 °C)	B65807-J-R97
N41	3100 + 30/- 20 %	1920	1450	< 0,16 (200 mT, 25 kHz, 100 °C)	B65807-J-R41

1) Preliminary data

Coil former, squared pins

Material: GFR thermosetting plastic (UL 94 V-0, insulation class to IEC 60085:

$H \geq$ max. operating temperature 180 °C), color code black

Solderability: to IEC 60068-2-20, test Ta, method 1 (aging 3): 235 °C, 2 s

Resistance to soldering heat: to IEC 60068-2-20, test Tb, method 1B: 350 °C, 3,5 s

Winding: see "Processing Notes", page 153

For matching clamp and insulating washers see page 210.

Sections	A_N mm ²	l_N mm	A_R value $\mu\Omega$	Pins	Ordering code
1	15	30	69	4 5 6 6	B65808-N1004-D1 B65808-N1005-D1 B65808-N1006-D1 B65808-W1006-D1
2	14	30	73	5 6	B65808-N1005-D2 B65808-N1006-D2

4 pins

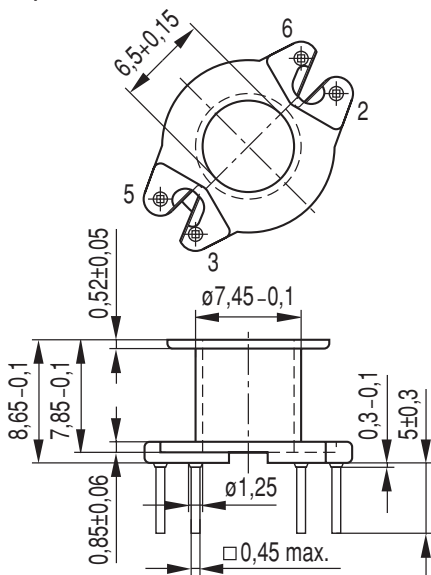

Hole arrangement
View in mounting direction

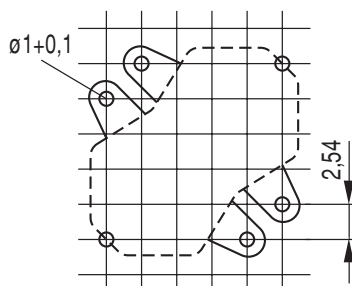

5 + 6 pins

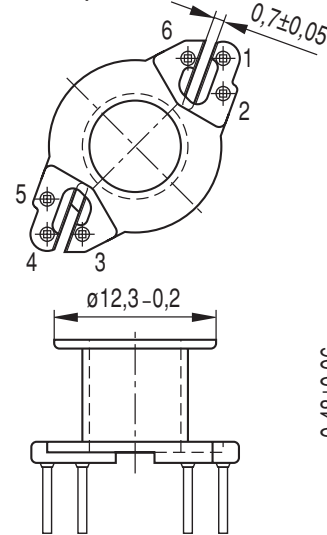

Pin 4 is omitted
in 5-pin version

Ground \varnothing 1,3±0,1

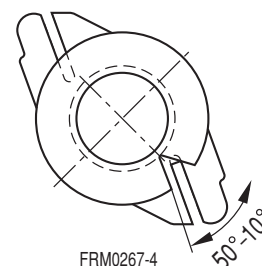
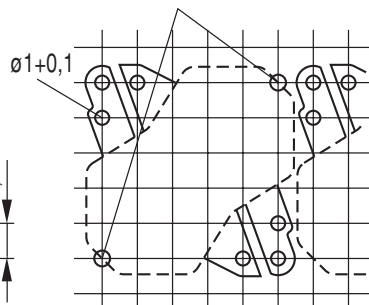

FRM0267-4

Coil former, pins squared in the start-of-winding area

Material: GFR thermosetting plastic (UL 94 V-0, insulation class to IEC 60085:

$H \cong \text{max. operating temperature } 180 \text{ }^\circ\text{C}$), color code blue

Solderability: to IEC 60068-2-20, test Ta, method 1 (aging 3): $235 \text{ }^\circ\text{C}$, 2 s

Resistance to soldering heat: to IEC 60068-2-20, test Tb, method 1B: $350 \text{ }^\circ\text{C}$, 3,5 s

Winding: see "Processing Notes", page 153

For matching clamp and insulating washers see page 210.

Sections	A_N mm ²	l_N mm	A_R value $\mu\Omega$	Pins	Ordering code
1	15	30	69	4	B65808-K1004-D1
				5	B65808-K1005-D1
				6	B65808-K1006-D1
2	14	30	73	4	B65808-K1004-D2
				6	B65808-K1006-D2

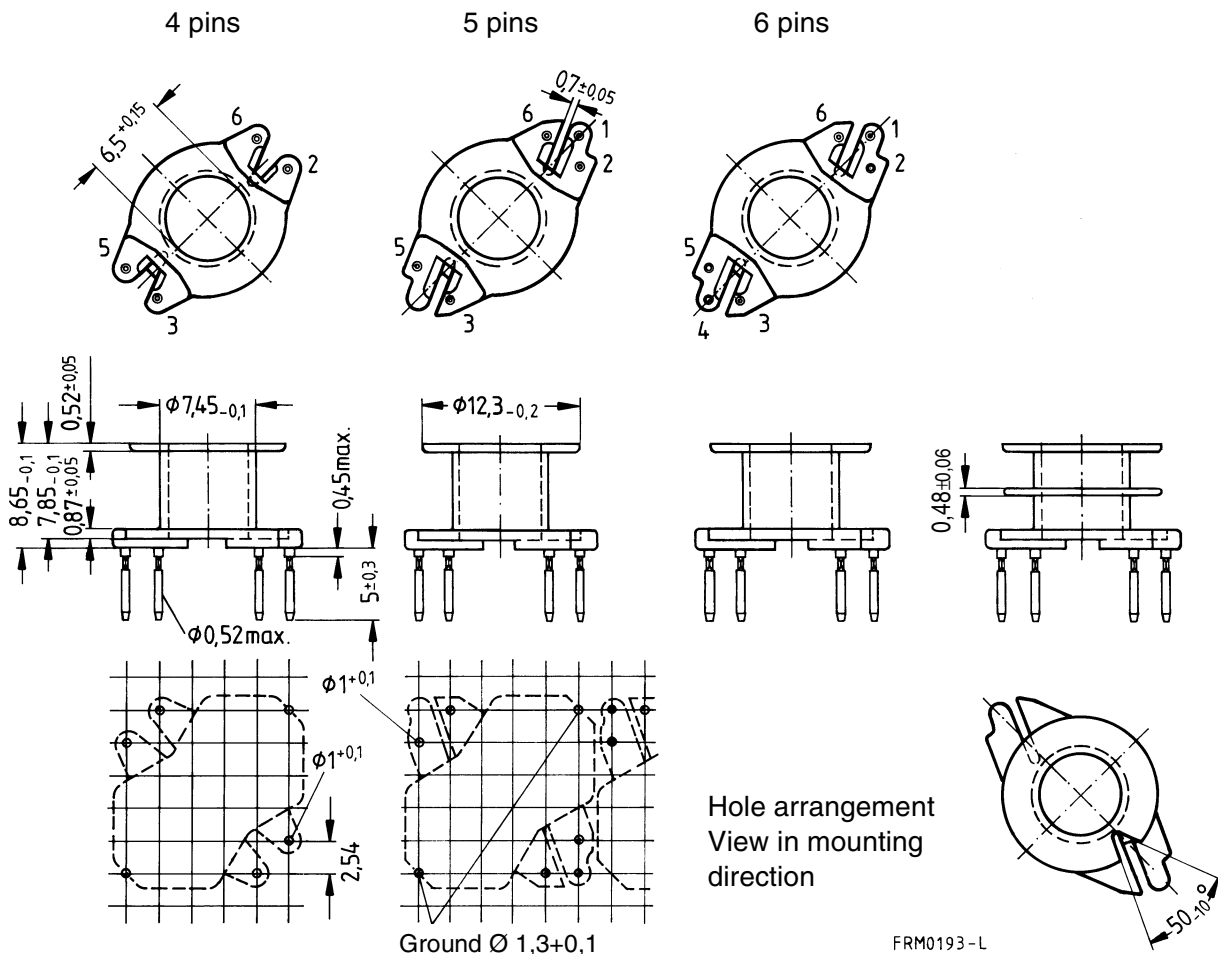

Coil former for SMPS transformers with line isolation

The creepage distances and clearances are designed such that the coil former is suitable for use in SMPS transformers with line isolation.

- Closed center flange with external wire guide
- Pins squared in the start-of-winding area
- Optimized for use with automatic winding machines

Material: GFR thermosetting plastic (UL 94 V-0, insulation class to IEC 60085:

F \triangleq max. operating temperature 155 °C), color code green

Solderability: to IEC 60068-2-20, test Ta, method 1 (aging 3): 235 °C, 2 s

Resistance to soldering heat: to IEC 60068-2-20, test Tb, method 1B: 350 °C, 3,5 s

Winding: see "Processing Notes", page 153

Sections	A_N mm ²	l_N mm	A_R value $\mu\Omega$	Pins	Ordering code
2	14	30	73	8	B65808-X1108-D2

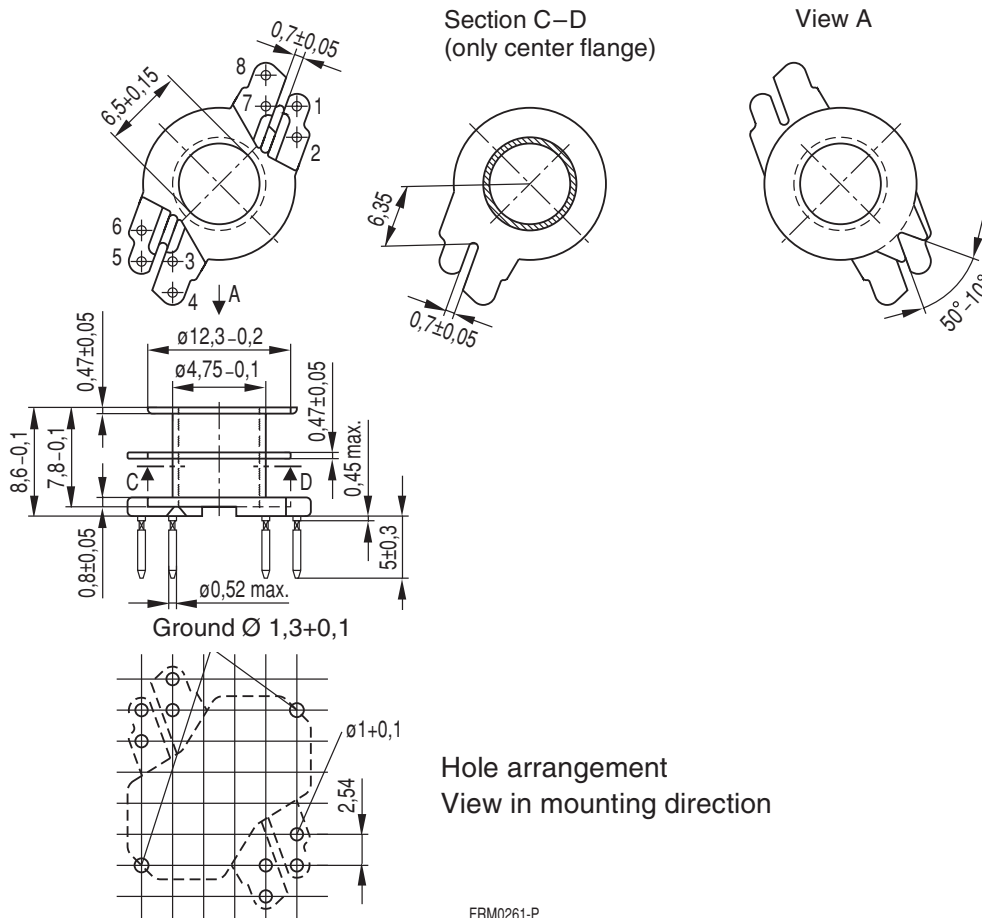

FRM0261-P

Coil former for power applications with angled pins

Optimized for automatic winding

Material: GFR polyterephthalate (UL 94 V-0, insulation class to IEC 60085:

$F \triangleq$ max. operating temperature 155 °C), color code black

Solderability: to IEC 60068-2-20, test Ta, method 1 (aging 3): 235 °C, 2 s

Resistance to soldering heat: to IEC 60068-2-20, test Tb, method 1B: 350 °C, 3,5 s

Winding: see "Processing Notes", page 153

For matching clamp and insulating washer 1 see page 210

Sections	A_N mm ²	l_N mm	A_R value $\mu\Omega$	Pins	Ordering code
1	15	30	69	8	B65808-E1508-T1

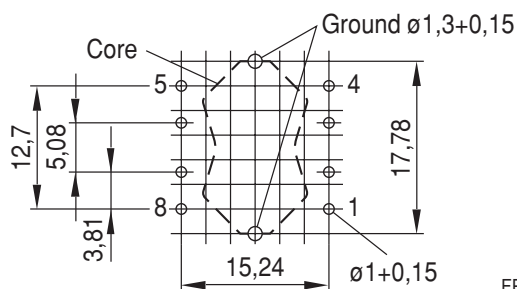
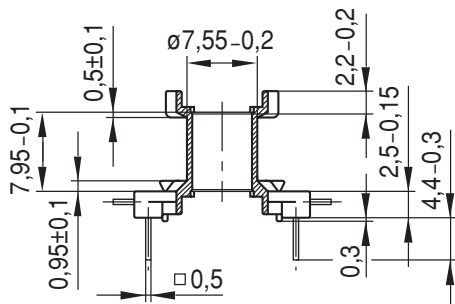
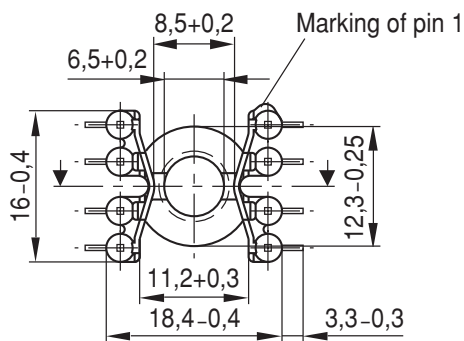

Hole arrangement
View in mounting direction

FRM0298-Y

Coil former for power applications with straight pins

Optimized for automatic winding

Material: GFR polyterephthalate (UL 94 V-0, insulation class to IEC 60085:

 $H \triangleq$ max. operating temperature 180 °C), color code black

Solderability: to IEC 60068-2-20, test Ta, method 1 (aging 3): 235 °C, 2 s

Resistance to soldering heat: to IEC 60068-2-20, test Tb, method 1B: 350 °C, 3,5 s

Winding: see "Processing Notes", page 153

For matching clamp and insulating washer 1 see page 210

Sections	A_N mm ²	l_N mm	A_R value $\mu\Omega$	Pins	Ordering code
1	15	30	69	8	B65808-W1508-T1

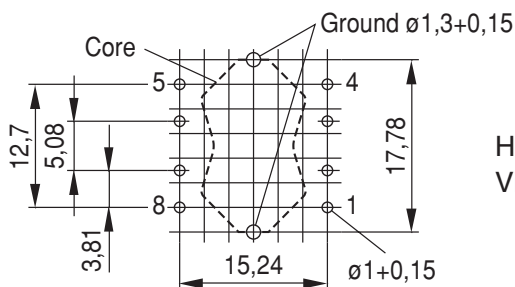
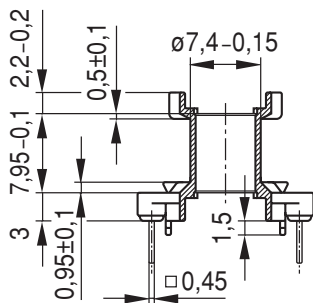
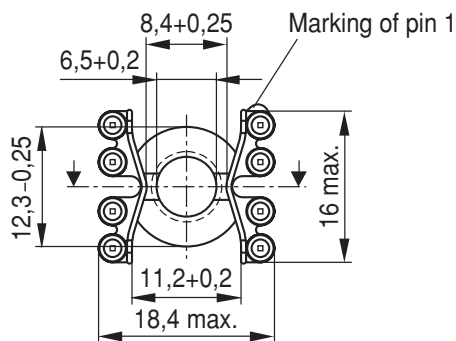
 Hole arrangement
View in mounting direction

FRM0299-7

Clamp

- With ground terminal, made of stainless spring steel (tinned), 0,435 mm thick
- Solderability to IEC 60068-2-20, test Ta, method 1 (aging 3): 235 °C, 2 s
- Also available as strip clamp on reels

Insulating washer 1 between core and coil former

- For tolerance compensation and for insulation
- Made of polycarbonate (UL 94 V-0, insulation class to IEC 60085: E \geq 120 °C), 0,08 mm thick

Insulating washer 2 for double-clad PCBs

- Made of polycarbonate (UL 94 V-0, insulation class to IEC 60085: E \geq 120 °C), 0,3 mm thick

	Ordering code
Clamp (ordering code per piece, 2 are required)	B65808-A2203
Insulating washer 1 (reel packing, PU = 1 reel)	B65808-A5000
Insulating washer 2 (bulk)	B65808-C2005

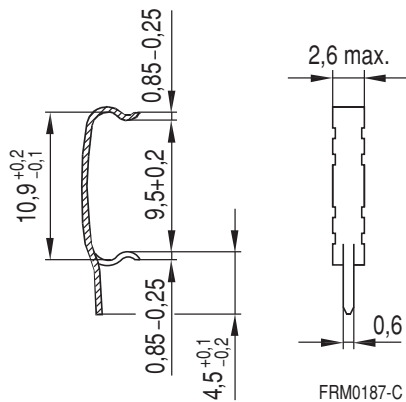
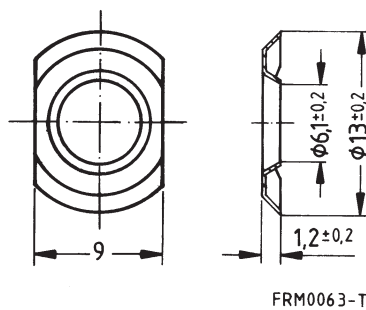
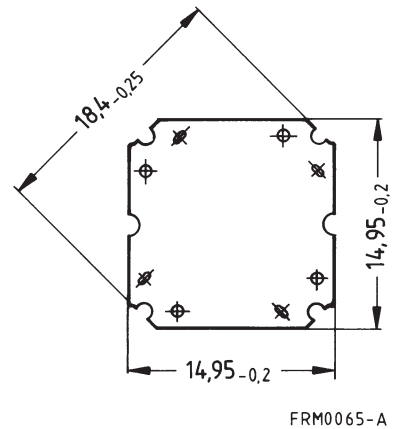
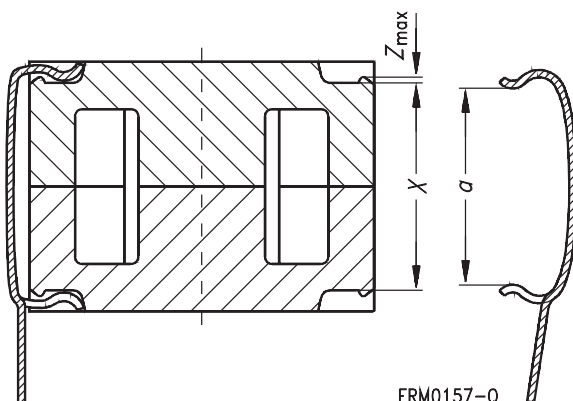
Clamp

Insulating washer 1

Insulating washer 2

Clamping forces for RM 6

F_{min} : Extension of clamp from a to $a_2 = X_{min}$
 F_{max} : Extension of clamp from a to $a_1 = X_{max}$

Clamp opening a (mm)	9,5 + 0,2	
Core nose Z_{max} (mm)	0,22	
Height of core pair X (mm)	X_{min}	10,1
	X_{max}	10,6
Clamping force F (N)	F_{min}	7
	F_{max}	50

SMD
SMD coil former with gullwing terminals

Material: GFR liquid crystal polymer (UL 94 V-0, insulation class to IEC 60085:

F $\hat{=}$ max. operating temperature 155 °C), color code black

Solderability: to IEC 60068-2-20, test Ta, method 1 (aging 3): 350 °C, 1 s

Resistance to soldering heat: to IEC 60068-2-20, test Tb, method 1B: 350 °C, 3,5 s

permissible soldering temperature for wire-wrap connection on coil former: 400 °C, 1 s

Winding: see "Processing Notes", page 160

Clamp

- Without ground terminal, made of stainless spring steel, 0,435 mm thick
- Also available as strip clamp (each carton containing 2 reels) on request

Sections	A_N mm ²	l_N mm	A_R value $\mu\Omega$	Terminals	Ordering code
1	16,2	31	66	8	B65821-C1008-T1
2	15,2	31	69	8	B65821-C1008-T2
Clamp (ordering code per piece, 2 are required)					B65808-J2204

Coil former

1 section

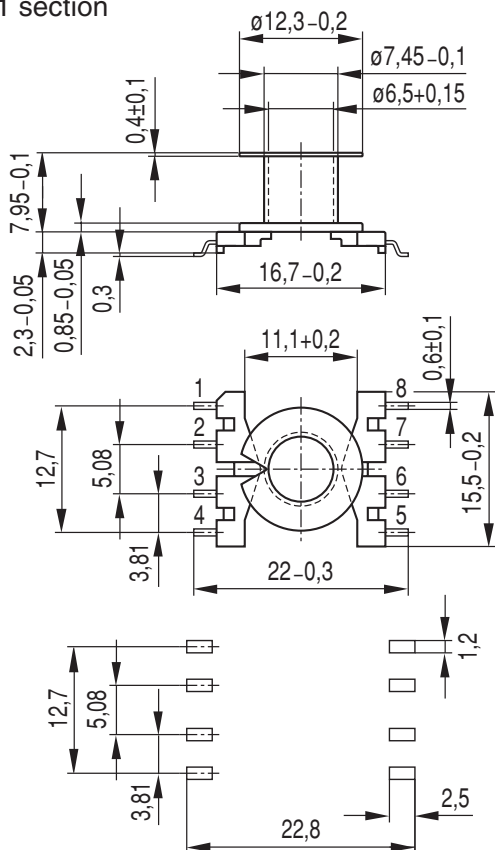

2 sections

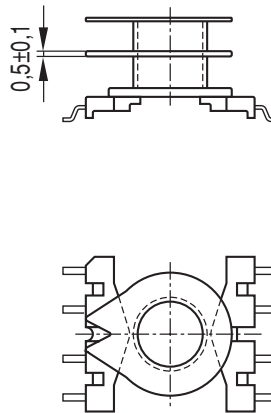
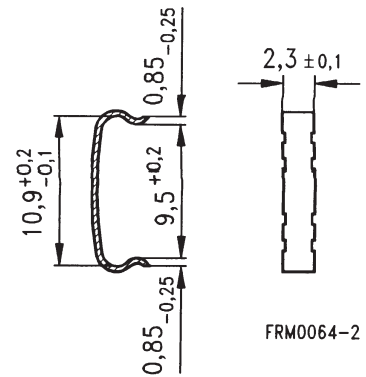
Clamp

FRM0064-2

Recommended
PCB layout

FRM0238-Q

SMD
SMD coil former with J terminals

Material: GFR liquid crystal polymer (UL 94 V-0, insulation class to IEC 60085:

F \triangleq max. operating temperature 155 °C), color code black

Solderability: to IEC 60068-2-20, test Ta, method 1 (aging 3): 350 °C, 1 s

Resistance to soldering heat: to IEC 60068-2-20, test Tb, method 1B: 350 °C, 3,5 s

permissible soldering temperature for wire-wrap connection on coil former: 400 °C, 1 s

Winding: see "Processing Notes", page 160

Clamp

- Without ground terminal, made of stainless spring steel, 0,435 mm thick
- Also available as strip clamp (each carton containing 2 reels) on request

Sections	A_N mm ²	l_N mm	A_R value $\mu\Omega$	Terminals	Ordering code
1	16,2	31	66	8	B65821-J1008-T1
Clamp	(ordering code per piece, 2 are required)				B65808-J2204

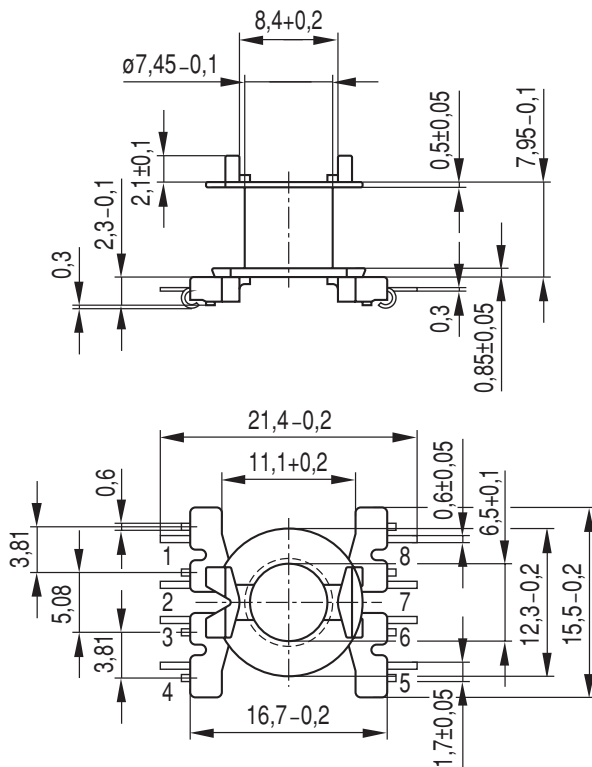
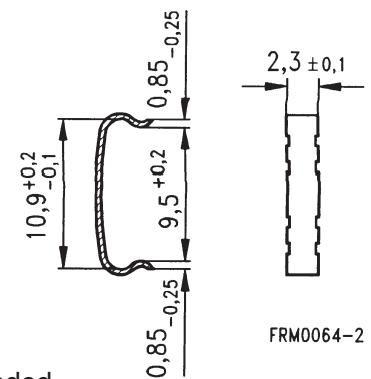
Coil former

Clamp

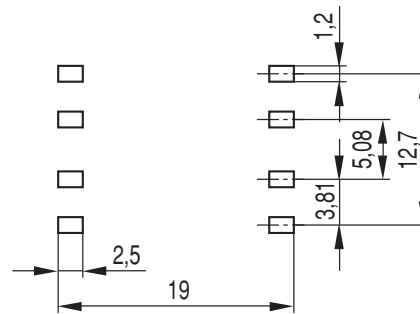
FRM0064-2

**Recommended
PCB layout**

FRM0239-Y

Adjusting screw

- Tube core with thread and core brake made of GFR polyterephthalate

Plastic **adjusting screwdriver** (not shown)

Plastic **handle** for adjusting screwdriver (not shown)

Core RM 6		Adjusting screw				Min. adjusting range %	Ordering code
Material	A _L value nH	Fig.	Tube core Ø × length mm	Material	Color code		
K 1	40	a	2,62 × 3,7	Si 1	white	15	B65659-F1-X101
M 33	63	a	2,62 × 3,7	Si 1	white	17	B65659-F1-X101
	100	c	2,82 × 4,4	Si 1	brown	16	B65659-F4-X101
N 48	160	a	2,62 × 3,7	K 1	green	17	B65659-F1-X1
	250	a	2,62 × 3,7	N 22	red	11	B65659-F1-X23
	315	b	2,75 × 4,4	N 22	black	13	B65659-F3-X23
	400	c	2,82 × 4,4	N 22	yellow	11	B65659-F4-X23
Adjusting screwdriver							B63399-B4
Handle							B63399-B5

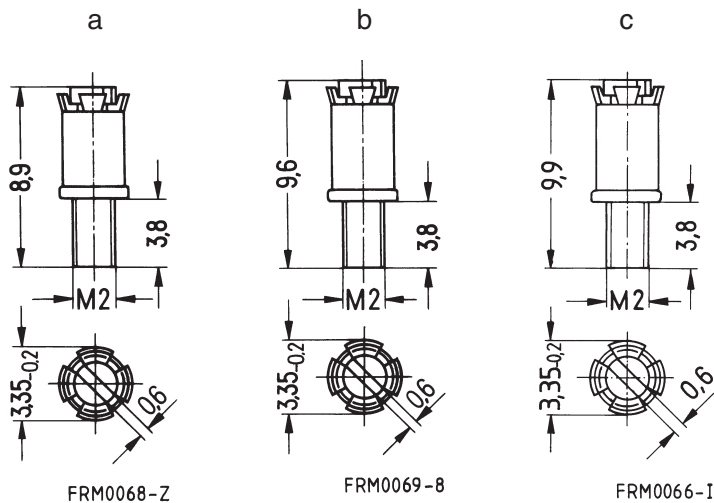
Adjusting screws

Herausgegeben von EPCOS AG

Marketing Kommunikation, Postfach 80 17 09, 81617 München, DEUTSCHLAND

© EPCOS AG 2000. Alle Rechte vorbehalten. Vervielfältigung, Veröffentlichung, Verbreitung und Verwertung dieser Broschüre und ihres Inhalts ohne ausdrückliche Genehmigung der EPCOS AG nicht gestattet.

Mit den Angaben in dieser Broschüre werden die Bauelemente spezifiziert, keine Eigenschaften zugesichert. Bestellungen unterliegen den vom ZVEI empfohlenen Allgemeinen Lieferbedingungen für Erzeugnisse und Leistungen der Elektroindustrie, soweit nichts anderes vereinbart wird.

Diese Broschüre ersetzt die vorige Ausgabe.

Fragen über Technik, Preise und Liefermöglichkeiten richten Sie bitte an den Ihnen nächstgelegenen Vertrieb der EPCOS AG oder an unsere Vertriebsgesellschaften im Ausland.

Bauelemente können aufgrund technischer Erfordernisse Gefahrstoffe enthalten. Auskünfte darüber bitten wir unter Angabe des betreffenden Typs ebenfalls über die zuständige Vertriebsgesellschaft einzuholen.

Published by EPCOS AG

Marketing Communications, P.O. Box 80 17 09, 81617 Munich, GERMANY

© EPCOS AG 2000. All Rights Reserved. Reproduction, publication and dissemination of this brochure and the information contained therein without EPCOS' prior express consent is prohibited.

The information contained in this brochure describes the type of component and shall not be considered as guaranteed characteristics. Purchase orders are subject to the General Conditions for the Supply of Products and Services of the Electrical and Electronics Industry recommended by the ZVEI (German Electrical and Electronic Manufacturers' Association), unless otherwise agreed.

This brochure replaces the previous edition.

For questions on technology, prices and delivery please contact the Sales Offices of EPCOS AG or the international Representatives.

Due to technical requirements components may contain dangerous substances. For information on the type in question please also contact one of our Sales Offices.