

PTC Thermistors, For Temperature Protection

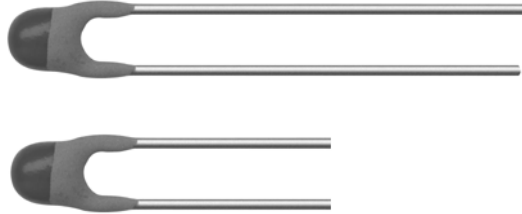

FEATURES

- Well-defined protection temperature levels
- Fast reaction time (< 15 s in still air)
- Accurate resistance for ease of circuit design
- Excellent long term behavior (< 1 °C or 5 % after 1000 hrs. at $T_n + 15$ °C)
- Wide range of protection temperatures (70 °C to 150 °C)
- No need to reset supply after overtemperature switch
- Small size and rugged
- Coated leaded and naked devices available
- Component in accordance to RoHS 2002/95/EC and WEEE 2002/96/EC

APPLICATIONS

- Industrial electronics
- Power supplies
- Electronic data processing
- Motor protection

DESCRIPTION

These directly heated thermistors have a positive temperature coefficient and are primarily intended for sensing.

QUICK REFERENCE DATA

PARAMETER	VALUE	UNIT
Maximum resistance at 25 °C	100	Ω
Minimum resistance at ($T_n + 15$) °C	4000	Ω
Maximum (DC) voltage	30	V
Temperature range	- 20 to ($T_n + 15$)	°C
Weight:		
91102 to 91114	≈ 0.08	g
91152 to 91164	≈ 0.11	g
Climatic category	25/125/56	

NOMINAL WORKING TEMPERATURES AND ORDERING INFORMATION

NOMINAL WORKING TEMPERATURE				CATALOG NUMBER 2381 671		
T_n (°C)	RESISTANCE from - 20 °C to $T_n - 20$ °C (Ω)	RESISTANCE at $T_n - 5$ °C (Ω)	RESISTANCE at $T_n + 5$ °C (k Ω)	LEADED DEVICE		COLOR CODE
				NORMAL LEADS	LONG LEADS	
70	30 to 250	50 to 570	0.570 to 50	91102	91152	black
80	30 to 250	50 to 550	1.33 to 50	91103	91153	brown
90	30 to 250	50 to 550	1.33 to 50	91104	91154	red
100	30 to 250	50 to 550	1.33 to 50	91105	91155	orange
110	30 to 250	50 to 550	1.33 to 50	91106	91156	yellow
120	30 to 250	50 to 550	1.33 to 50	91107	91157	green
130	30 to 250	50 to 550	1.33 to 50	91109	91159	blue
140	30 to 250	50 to 550	1.33 to 50	91112	91162	violet
150	30 to 250	50 to 550	1.33 to 50	91114	91164	grey

ELECTRICAL CHARACTERISTICS	
PARAMETER	VALUES
Maximum resistance at 25 °C	100 Ω
Maximum resistance at (T _n - 5) °C	see Nominal Working Temperatures and Ordering Information table
Minimum resistance at (T _n + 15) °C	4000 Ω
Minimum resistance at (T _n + 5) °C	see Nominal Working Temperatures and Ordering Information table
Maximum voltage	30 V (AC or DC)

CATALOG NUMBERS AND PACKAGING				
12 NC	SAP	12 NC	SAP	SPQ
2381 671 91102	PTCSL20T071DBE	2381 671 91152	PTCSL40T071DBE	500
2381 671 91103	PTCSL20T081DBE	2381 671 91153	PTCSL40T081DBE	500
2381 671 91104	PTCSL20T091DBE	2381 671 91154	PTCSL40T091DBE	500
2381 671 91105	PTCSL20T101DBE	2381 671 91155	PTCSL40T101DBE	500
2381 671 91106	PTCSL20T111DBE	2381 671 91156	PTCSL40T111DBE	500
2381 671 91107	PTCSL20T121DBE	2381 671 91157	PTCSL40T121DBE	500
2381 671 91109	PTCSL20T131DBE	2381 671 91159	PTCSL40T131DBE	500
2381 671 91112	PTCSL20T141DBE	2381 671 91162	PTCSL40T141DBE	500
2381 671 91114	PTCSL20T151DBE	2381 671 91164	PTCSL40T151DBE	500

COMPONENT OUTLINES

Dimensions in millimeters

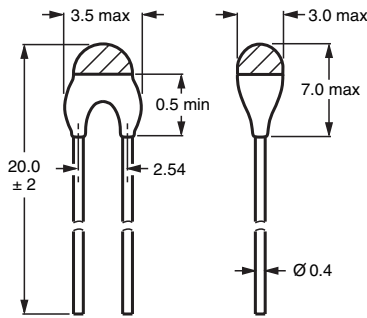

Component outline for 91102 to 91114

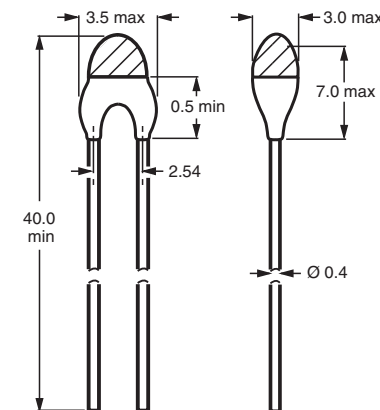

Component outline for 91152 to 91164

TYPICAL RESISTANCE/TEMPERATURE CHARACTERISTIC FOR 2381 671 91105/91106 and 91107

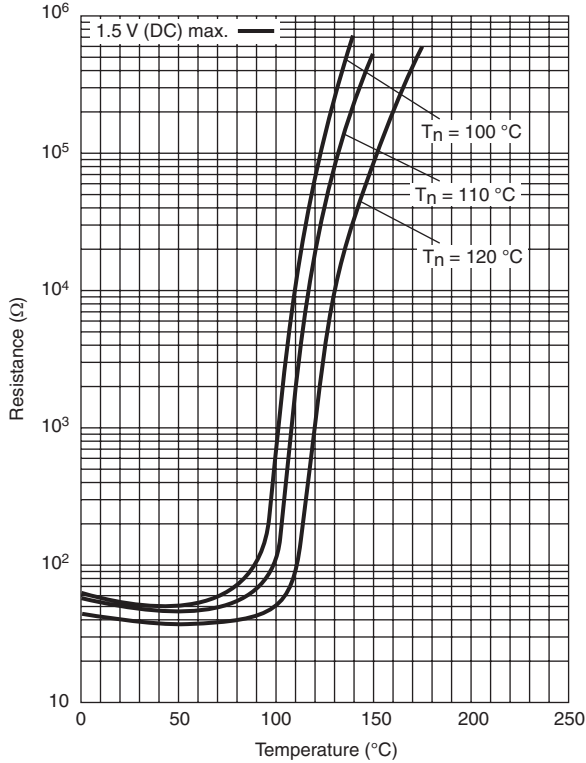

TYPICAL RESISTANCE/TEMPERATURE CHARACTERISTIC FOR 2381 671 91102/91103 and 91104

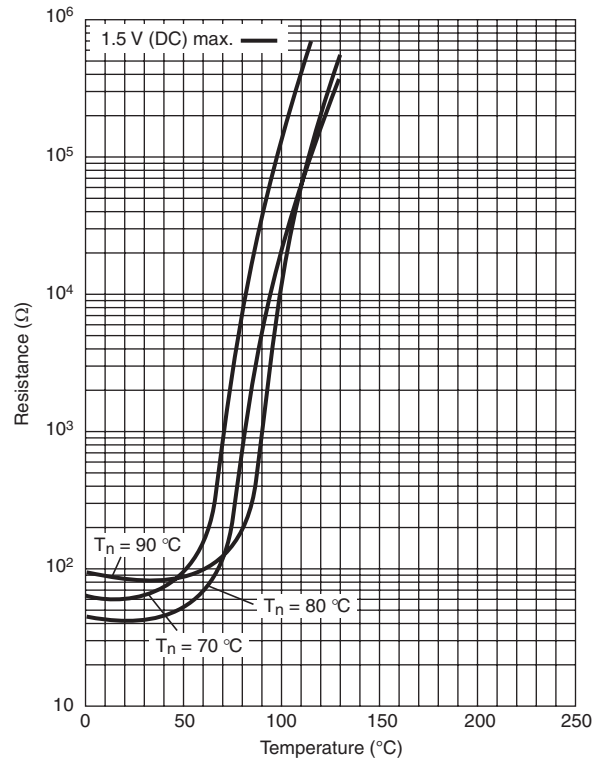

TYPICAL RESISTANCE/TEMPERATURE CHARACTERISTIC FOR 2381 671 91109

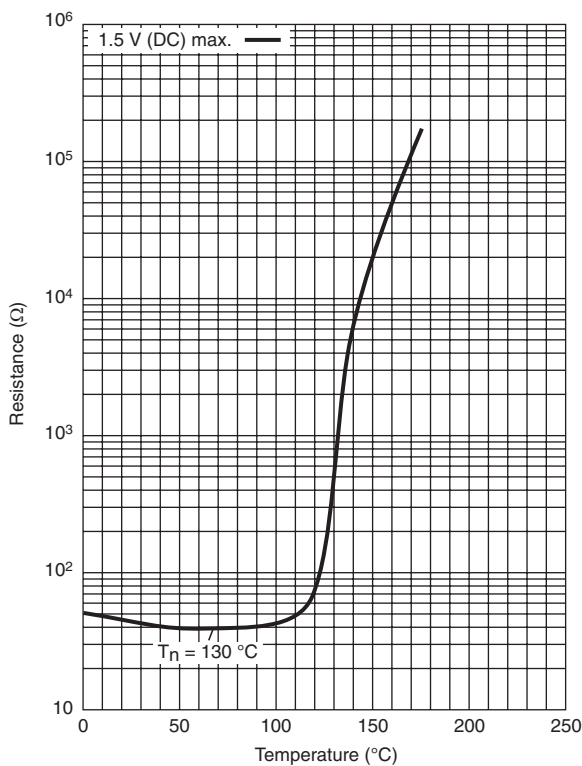

TYPICAL RESISTANCE/TEMPERATURE CHARACTERISTIC FOR 2381 671 91112 and 91114

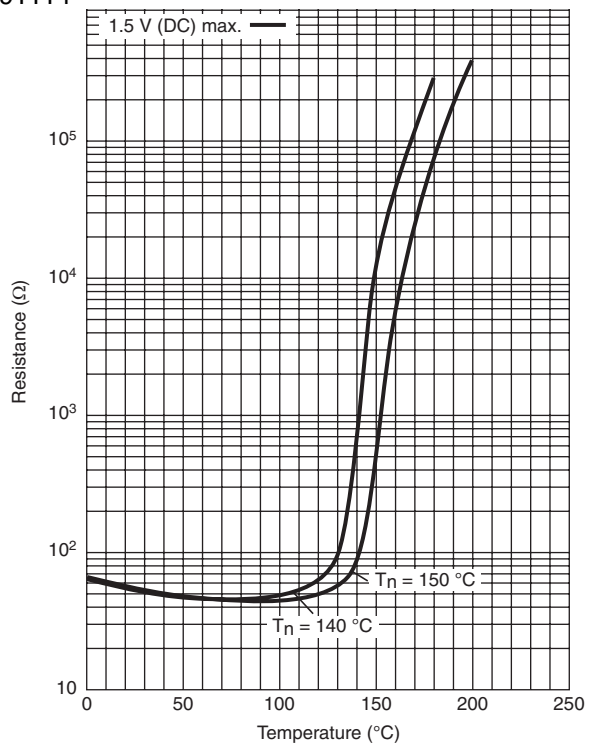

APPLICATION SPECIFIC DATA

Negative Temperature Coefficient (NTC) thermistors are well known for temperature sensing. What is not well known, however, is that Positive Temperature Coefficient (PTC) thermistors can be used for thermal protection. Although their operating principles are similar, the applications are very different; whereas NTC thermistors sense and measure temperature over a defined range, PTC thermistors switch at one particular temperature.

Just like thermostats they protect such equipment and components as motors, transformers, power transistors and thyristors against overtemperature. A PTC thermistor is less expensive than a thermostat, and its switch temperature can be more accurately specified. It is also smaller and easier to design-in to electronic circuitry.

So how does it work? The PTC thermistor is mounted in thermal contact with the equipment to be protected, and connected into the bridge arm of a comparator circuit, such as shown in Fig. 1. At normal temperature, the PTC thermistor resistance (R_p) is lower than R_s (see Fig. 2), so the comparator's output voltage V_o will be low. If an equipment overtemperature occurs, the PTC thermistor will quickly heat up to its trigger or nominal reference temperature T_n , whereupon its resistance will increase to a value much higher than R_s , causing V_o to switch to a high level sufficient to activate an alarm, relay or power shutdown circuit.

APPLICATION EXAMPLES

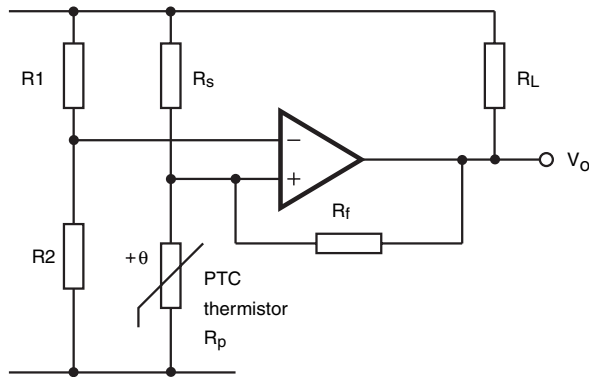

Fig. 1 Typical comparator circuit

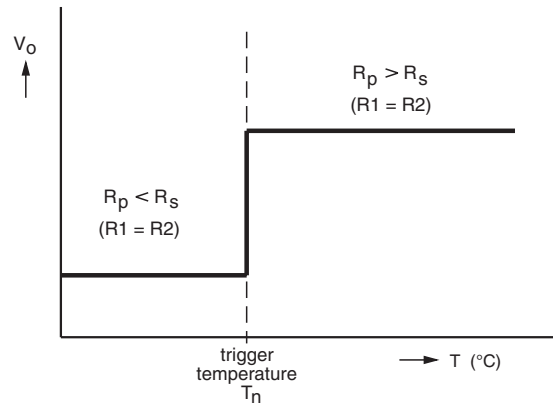
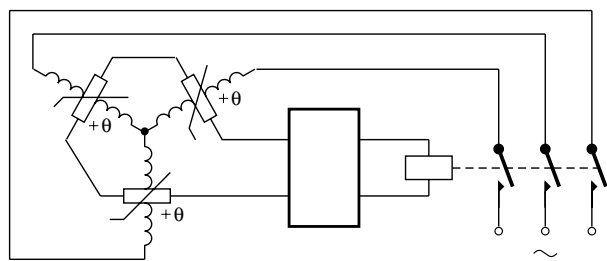
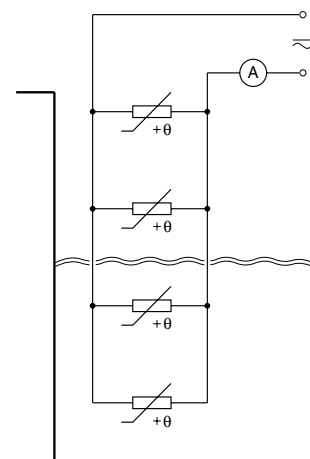

Fig. 2 Typical switch characteristic



As soon as one or more of the windings becomes too hot, the motor is switched off.

Fig. 3 Temperature protection of electric motors



The PTC thermistors located above the fluid level will be heated to a temperature greater than T_n . When immersed they are cooled such that their resistance value is reduced.

Fig. 4 Liquid-level indication



Disclaimer

All product specifications and data are subject to change without notice.

Vishay Intertechnology, Inc., its affiliates, agents, and employees, and all persons acting on its or their behalf (collectively, "Vishay"), disclaim any and all liability for any errors, inaccuracies or incompleteness contained herein or in any other disclosure relating to any product.

Vishay disclaims any and all liability arising out of the use or application of any product described herein or of any information provided herein to the maximum extent permitted by law. The product specifications do not expand or otherwise modify Vishay's terms and conditions of purchase, including but not limited to the warranty expressed therein, which apply to these products.

No license, express or implied, by estoppel or otherwise, to any intellectual property rights is granted by this document or by any conduct of Vishay.

The products shown herein are not designed for use in medical, life-saving, or life-sustaining applications unless otherwise expressly indicated. Customers using or selling Vishay products not expressly indicated for use in such applications do so entirely at their own risk and agree to fully indemnify Vishay for any damages arising or resulting from such use or sale. Please contact authorized Vishay personnel to obtain written terms and conditions regarding products designed for such applications.

Product names and markings noted herein may be trademarks of their respective owners.