

- **Surface Mount**
- **High CV**
- **Vertical Chip**
- **Solvent Proof (4-63V)**
- **+85°C Maximum Temperature**

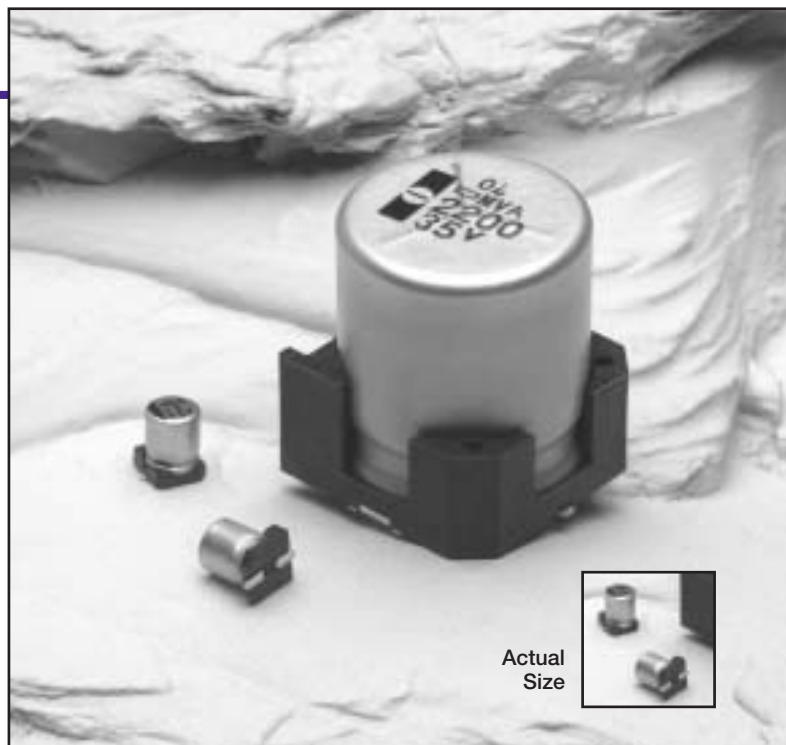

The MVA series is a general purpose +85°C surface mount capacitor series from United Chemi-Con. This series has higher CV values, higher voltage ratings and larger case size options, when compared to the current MV series. The larger sizes and higher voltages will allow a surface mount component to be used in a wider variety of applications where a radial capacitor would normally be required.

The MVA series capacitors *except for those rated at 100-450 volts* are solvent proof. Refer to the Mini-Glossary for cleaning guidelines and recommended cleaning agents that are compatible with United Chemi-Con products.

Summary of Specifications

- **Surface mount lead terminals.**
- **Capacitance range: 0.1 to 10,000µF.**
- **Voltage range: 4 to 450VDC.**
- **Category temperature range: -40°C to +85°C.**
- **Leakage current: See specifications table for leakage current values at +20°C.**
- **Standard capacitance tolerance: ±20%**
- **Nominal case size (D×L): 4×5.2mm to 18×21.5mm.**
- **Rated lifetime: 2,000 hours at +85°C.**

MVA Specifications

Item	Characteristics																																																															
Category Temperature Range	- 40 to +85°C																																																															
Rated Voltage Range	4 to 450VDC																																																															
Capacitance Range	0.1 to 10,000 μ F																																																															
Capacitance Tolerance	\pm 20% (M) at +20°C, 120Hz																																																															
Leakage Current	<table border="1"> <tr> <td>Case D55-J10</td> <td>4-100V</td> <td>I = 0.01CV or 3μA, whichever is greater, after 2 minutes at +20°C</td> </tr> <tr> <td>Case K14-M22</td> <td>6.3-100V</td> <td>I = 0.03CV or 4μA, whichever is greater, after 1 minute at +20°C</td> </tr> <tr> <td>Case K14-M22</td> <td>160-450V</td> <td>I = 0.04CV + 100μA after 1 minute at +20°C</td> </tr> </table> <p>Where I = Max. leakage current (μA), C = Nominal capacitance (μF) and V = Rated voltage (V)</p>	Case D55-J10	4-100V	I = 0.01CV or 3 μ A, whichever is greater, after 2 minutes at +20°C	Case K14-M22	6.3-100V	I = 0.03CV or 4 μ A, whichever is greater, after 1 minute at +20°C	Case K14-M22	160-450V	I = 0.04CV + 100 μ A after 1 minute at +20°C																																																						
Case D55-J10	4-100V	I = 0.01CV or 3 μ A, whichever is greater, after 2 minutes at +20°C																																																														
Case K14-M22	6.3-100V	I = 0.03CV or 4 μ A, whichever is greater, after 1 minute at +20°C																																																														
Case K14-M22	160-450V	I = 0.04CV + 100 μ A after 1 minute at +20°C																																																														
Dissipation Factor (Tan δ)	<p>At +20°C, 120Hz</p> <table border="1"> <tr> <td>Rated Voltage (V)</td> <td>4</td> <td>6.3</td> <td>10</td> <td>16</td> <td>25</td> <td>35</td> <td>50</td> <td>63</td> <td>100</td> <td>160-250</td> <td>400-450</td> </tr> <tr> <td>Case D55-J10</td> <td>0.42</td> <td>0.35</td> <td>0.30</td> <td>0.26</td> <td>0.16</td> <td>0.14</td> <td>0.12</td> <td>0.12</td> <td>0.12</td> <td>-</td> <td>-</td> </tr> <tr> <td>Case K14-M22</td> <td>-</td> <td>0.38</td> <td>0.34</td> <td>0.30</td> <td>0.26</td> <td>0.22</td> <td>0.18</td> <td>0.14</td> <td>0.10</td> <td>0.20</td> <td>0.25</td> </tr> </table> <p>When nominal capacitance exceeds 1,000μF, add 0.02 to the values above for each 1,000μF increase.</p>	Rated Voltage (V)	4	6.3	10	16	25	35	50	63	100	160-250	400-450	Case D55-J10	0.42	0.35	0.30	0.26	0.16	0.14	0.12	0.12	0.12	-	-	Case K14-M22	-	0.38	0.34	0.30	0.26	0.22	0.18	0.14	0.10	0.20	0.25																											
Rated Voltage (V)	4	6.3	10	16	25	35	50	63	100	160-250	400-450																																																					
Case D55-J10	0.42	0.35	0.30	0.26	0.16	0.14	0.12	0.12	0.12	-	-																																																					
Case K14-M22	-	0.38	0.34	0.30	0.26	0.22	0.18	0.14	0.10	0.20	0.25																																																					
Low Temperature Characteristics	<p>At 120Hz, impedance (Z) ratio between the -25°C or -40°C value and +20°C value shall not exceed the values given below.</p> <table border="1"> <tr> <td>Rated Voltage (V)</td> <td></td> <td>4</td> <td>6.3</td> <td>10</td> <td>16</td> <td>25</td> <td>35</td> <td>50</td> <td>63</td> <td>100</td> <td>160-250</td> <td>400-450</td> </tr> <tr> <td rowspan="2">Z(-25°C) / Z(+20°C)</td> <td>D55-J10</td> <td>7</td> <td>4</td> <td>3</td> <td>2</td> <td>2</td> <td>2</td> <td>2</td> <td>2</td> <td>3</td> <td>-</td> <td>-</td> </tr> <tr> <td>K14-M22</td> <td>-</td> <td>5</td> <td>4</td> <td>3</td> <td>2</td> <td>2</td> <td>2</td> <td>2</td> <td>2</td> <td>3</td> <td>6</td> </tr> <tr> <td rowspan="2">Z(-40°C) / Z(+20°C)</td> <td>D55-J10</td> <td>17</td> <td>10</td> <td>8</td> <td>6</td> <td>4</td> <td>3</td> <td>3</td> <td>3</td> <td>4</td> <td>-</td> <td>-</td> </tr> <tr> <td>K14-M22</td> <td>-</td> <td>12</td> <td>10</td> <td>8</td> <td>5</td> <td>4</td> <td>3</td> <td>3</td> <td>3</td> <td>6</td> <td>10</td> </tr> </table>	Rated Voltage (V)		4	6.3	10	16	25	35	50	63	100	160-250	400-450	Z(-25°C) / Z(+20°C)	D55-J10	7	4	3	2	2	2	2	2	3	-	-	K14-M22	-	5	4	3	2	2	2	2	2	3	6	Z(-40°C) / Z(+20°C)	D55-J10	17	10	8	6	4	3	3	3	4	-	-	K14-M22	-	12	10	8	5	4	3	3	3	6	10
Rated Voltage (V)		4	6.3	10	16	25	35	50	63	100	160-250	400-450																																																				
Z(-25°C) / Z(+20°C)	D55-J10	7	4	3	2	2	2	2	2	3	-	-																																																				
	K14-M22	-	5	4	3	2	2	2	2	2	3	6																																																				
Z(-40°C) / Z(+20°C)	D55-J10	17	10	8	6	4	3	3	3	4	-	-																																																				
	K14-M22	-	12	10	8	5	4	3	3	3	6	10																																																				
Endurance (Load Life)	<p>The following specifications shall be satisfied when the capacitors are restored to +20°C after subjecting them to the DC rated voltage for 2,000 hours at +85°C.</p> <table border="0"> <tr> <td style="vertical-align: top;"> <p>Case Code D55-J10 (4V & 6.3V)</p> <hr/> <p>Capacitance change: $\leq \pm$30% of initial measured value</p> <p>Tan δ (DF): \leq 200% of initial specified value</p> <p>Leakage current: \leq initial specified value</p> </td> <td style="vertical-align: top; padding-left: 20px;"> <p>Case Code D55-J10 (10-100V) and K14-M22 (6.3-450V)</p> <hr/> <p>Capacitance change: $\leq \pm$20% of initial measured value</p> <p>Tan δ (DF): \leq 200% of initial specified value</p> <p>Leakage current: \leq initial specified value</p> </td> </tr> </table>	<p>Case Code D55-J10 (4V & 6.3V)</p> <hr/> <p>Capacitance change: $\leq \pm$30% of initial measured value</p> <p>Tan δ (DF): \leq 200% of initial specified value</p> <p>Leakage current: \leq initial specified value</p>	<p>Case Code D55-J10 (10-100V) and K14-M22 (6.3-450V)</p> <hr/> <p>Capacitance change: $\leq \pm$20% of initial measured value</p> <p>Tan δ (DF): \leq 200% of initial specified value</p> <p>Leakage current: \leq initial specified value</p>																																																													
<p>Case Code D55-J10 (4V & 6.3V)</p> <hr/> <p>Capacitance change: $\leq \pm$30% of initial measured value</p> <p>Tan δ (DF): \leq 200% of initial specified value</p> <p>Leakage current: \leq initial specified value</p>	<p>Case Code D55-J10 (10-100V) and K14-M22 (6.3-450V)</p> <hr/> <p>Capacitance change: $\leq \pm$20% of initial measured value</p> <p>Tan δ (DF): \leq 200% of initial specified value</p> <p>Leakage current: \leq initial specified value</p>																																																															
Shelf Life	<p>The following specifications shall be satisfied when the capacitors are restored to +20°C after exposing them for 1,000 hours at +85°C without voltage applied. The rated voltage shall be applied to the capacitors for a minimum of 30 minutes, at least 24 hours and not more than 48 hours before the measurements.</p> <table border="0"> <tr> <td style="vertical-align: top;"> <p>Case Code D55-J10 (4V & 6.3V)</p> <hr/> <p>Capacitance change: $\leq \pm$30% of initial measured value</p> <p>Tan δ (DF): \leq 200% of initial specified value</p> <p>Leakage current: \leq initial specified value</p> </td> <td style="vertical-align: top; padding-left: 20px;"> <p>Case Code D55-J10 (10-100V) and K14-M22 (6.3-450V)</p> <hr/> <p>Capacitance change: $\leq \pm$20% of initial measured value</p> <p>Tan δ (DF): \leq 200% of initial specified value</p> <p>Leakage current: \leq initial specified value</p> </td> </tr> </table>	<p>Case Code D55-J10 (4V & 6.3V)</p> <hr/> <p>Capacitance change: $\leq \pm$30% of initial measured value</p> <p>Tan δ (DF): \leq 200% of initial specified value</p> <p>Leakage current: \leq initial specified value</p>	<p>Case Code D55-J10 (10-100V) and K14-M22 (6.3-450V)</p> <hr/> <p>Capacitance change: $\leq \pm$20% of initial measured value</p> <p>Tan δ (DF): \leq 200% of initial specified value</p> <p>Leakage current: \leq initial specified value</p>																																																													
<p>Case Code D55-J10 (4V & 6.3V)</p> <hr/> <p>Capacitance change: $\leq \pm$30% of initial measured value</p> <p>Tan δ (DF): \leq 200% of initial specified value</p> <p>Leakage current: \leq initial specified value</p>	<p>Case Code D55-J10 (10-100V) and K14-M22 (6.3-450V)</p> <hr/> <p>Capacitance change: $\leq \pm$20% of initial measured value</p> <p>Tan δ (DF): \leq 200% of initial specified value</p> <p>Leakage current: \leq initial specified value</p>																																																															

Diagram of Dimensions

Vertical Chip SMD Lead Terminals

Unit: mm

VC Type $\varnothing D = \varnothing 4 - \varnothing 12.5^*$

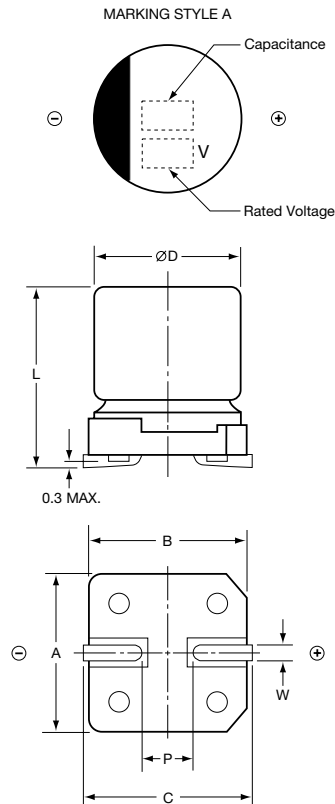

VD Type $\varnothing D = \varnothing 16 \text{ \& } \varnothing 18$

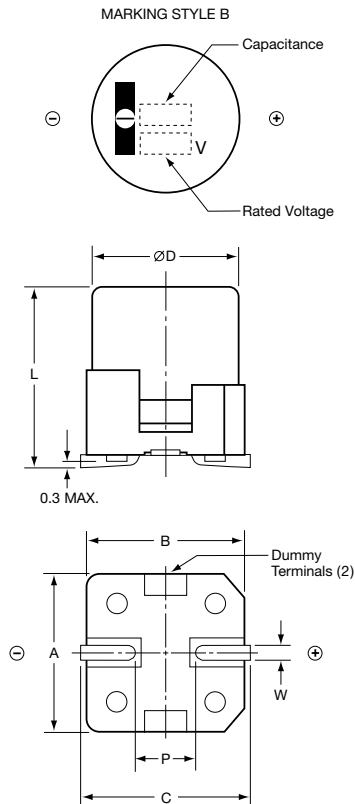

Recommended PCB Land Patterns

VC Type $\varnothing D = \varnothing 4 - \varnothing 12.5$

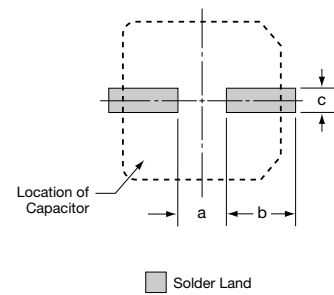

VD Type $\varnothing D = \varnothing 16 \text{ \& } \varnothing 18$

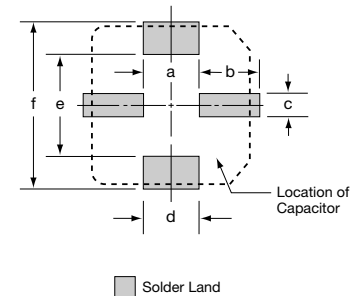

*Marking Style B is used for all $\varnothing 12.5$ VC Type products.

Refer to Packaging section for Surface Mount taping, reel and tray specifications and Surface Mount Soldering section for reflow soldering conditions.

Case and PCB Land Pattern Dimensions

Case Code	$\varnothing D \pm 0.5$	L	A ± 0.2	B ± 0.2	C ± 0.2	W	P	a	b	c	d	e	f
D55	$\varnothing 4$	5.2 ± 0.3	4.3	4.3	5.1	0.5-0.8	1.0	1.0	2.6	1.6	-	-	-
E55	$\varnothing 5$	5.2 ± 0.3	5.3	5.3	5.9	0.5-0.8	1.4	1.4	3.0	1.6	-	-	-
F55	$\varnothing 6.3$	5.2 ± 0.3	6.6	6.6	7.2	0.5-0.8	1.9	1.9	3.5	1.6	-	-	-
F60	$\varnothing 6.3$	5.7 ± 0.3	6.6	6.6	7.2	0.5-0.8	1.9	1.9	3.5	1.6	-	-	-
F80	$\varnothing 6.3$	7.7 ± 0.3	6.6	6.6	7.2	0.5-0.8	1.9	1.9	3.5	1.6	-	-	-
H10	$\varnothing 8$	10.0 ± 0.5	8.3	8.3	9.0	0.7-1.1	3.1	3.1	4.2	2.2	-	-	-
J10	$\varnothing 10$	10.0 ± 0.5	10.3	10.3	11.0	0.7-1.1	4.5	4.5	4.4	2.2	-	-	-
K14	$\varnothing 12.5$	13.5 ± 0.5	13.0	13.0	13.7	1.0-1.3	4.2	4.0	5.7	2.5	-	-	-
K16	$\varnothing 12.5$	16.0 ± 0.5	13.0	13.0	13.7	1.0-1.3	4.2	4.0	5.7	2.5	-	-	-
L17	$\varnothing 16$	16.5 ± 0.5	17.0	17.0	18.0	1.0-1.3	6.5	6.0	6.9	2.5	6.5	11.0	19.2
L22	$\varnothing 16$	21.5 ± 0.5	17.0	17.0	18.0	1.0-1.3	6.5	6.0	6.9	2.5	6.5	11.0	19.2
M17	$\varnothing 18$	16.5 ± 0.5	19.0	19.0	20.0	1.0-1.3	6.5	6.0	7.9	2.5	6.5	13.0	21.2
M22	$\varnothing 18$	21.5 ± 0.5	19.0	19.0	20.0	1.0-1.3	6.5	6.0	7.9	2.5	6.5	13.0	21.2

Part Numbering System for MVA Series When ordering, always specify complete catalog number for MVA Series.

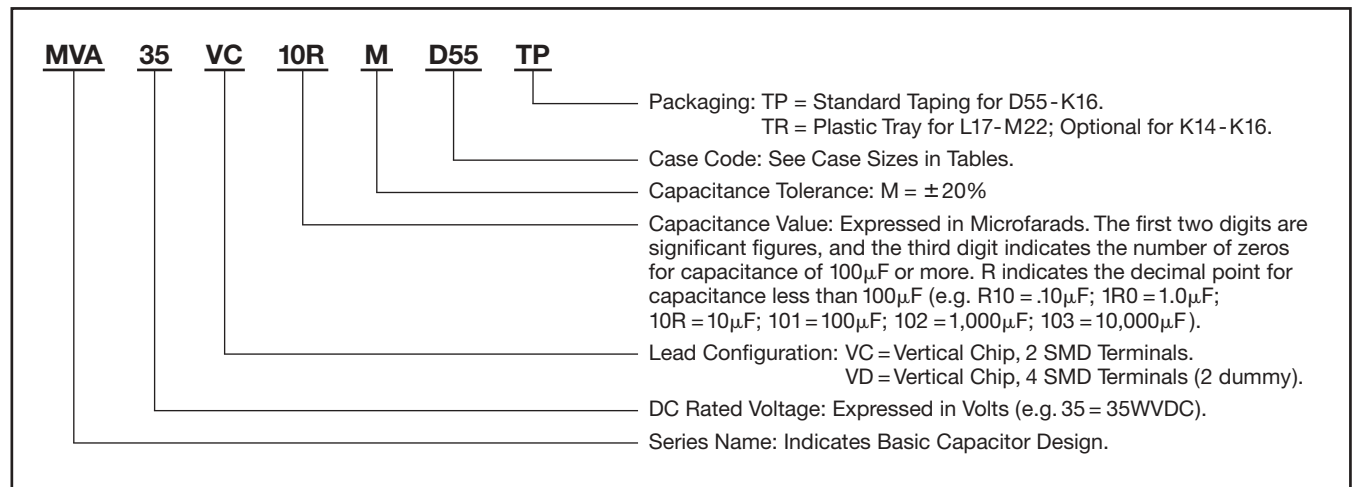

Standard Voltage Ratings - Surface Mount

Rated Voltage (WVDC)	Capacitance (μ F)	Catalog Part Number	Nominal Case Size* D x L (mm)	Case Code	Maximum ESR (Ω) at +20°C, 120Hz	Rated Ripple Current (mA rms) at +85°C, 120Hz
4 Volts 5 Volts Surge	33	MVA4VC33RMD55TP	4 x 5.2	D55	21.095	25
	47	MVA4VC47RMD55TP	4 x 5.2	D55	14.812	30
	100	MVA4VC101ME55TP	5 x 5.2	E55	6.962	50
	220	MVA4VC221MF55TP	6.3 x 5.2	F55	3.164	80
	330	MVA4VC331MF80TP	6.3 x 7.7	F80	2.11	135
	470	MVA4VC471MF80TP	6.3 x 7.7	F80	1.481	150
	1,000	MVA4VC102MH10TP	8 x 10	H10	0.696	320
6.3 Volts 8 Volts Surge	33	MVA6.3VC33RMD55TP	4 x 5.2	D55	17.58	30
	47	MVA6.3VC47RMD55TP	4 x 5.2	D55	12.343	33
	100	MVA6.3VC101ME55TP	5 x 5.2	E55	5.801	55
	220	MVA6.3VC221MF55TP	6.3 x 5.2	F55	2.637	88
	330	MVA6.3VC331MF80TP	6.3 x 7.7	F80	1.758	135
	470	MVA6.3VC471MH10TP	8 x 10	H10	1.234	280
	680	MVA6.3VC681MH10TP	8 x 10	H10	0.853	290
	820	MVA6.3VC821MH10TP	8 x 10	H10	0.707	320
	1,000	MVA6.3VC102MJ10TP	10 x 10	J10	0.58	430
	1,500	MVA6.3VC152MJ10TP	10 x 10	J10	0.387	480
	2,200	MVA6.3VC222MK14TP	12.5 x 13.5	K14	0.301	890
	3,300	MVA6.3VC332MK16TP	12.5 x 16	K16	0.211	1,000
	3,300	MVA6.3VD332ML17TR	16 x 16.5	L17	0.211	1,200
	4,700	MVA6.3VD472ML17TR	16 x 16.5	L17	0.155	1,400
	6,800	MVA6.3VD682ML22TR	16 x 21.5	L22	0.117	1,750
6,800	MVA6.3VD682MM17TR	18 x 16.5	M17	0.117	1,700	
10,000	MVA6.3VD103MM22TR	18 x 21.5	M22	0.093	2,000	
10 Volts 13 Volts Surge	22	MVA10VC22RMD55TP	4 x 5.2	D55	22.602	26
	33	MVA10VC33RMD55TP	4 x 5.2	D55	15.068	30
	47	MVA10VC47RME55TP	5 x 5.2	E55	10.58	44
	100	MVA10VC101MF55TP	6.3 x 5.2	F55	4.973	70
	150	MVA10VC151MF55TP	6.3 x 5.2	F55	3.315	79
	220	MVA10VC221MF80TP	6.3 x 7.7	F80	2.26	130
	330	MVA10VC331MH10TP	8 x 10	H10	1.507	270
	470	MVA10VC471MH10TP	8 x 10	H10	1.058	280
	1,000	MVA10VC102MJ10TP	10 x 10	J10	0.497	430
	2,200	MVA10VC222MK14TP	12.5 x 13.5	K14	0.271	960
	3,300	MVA10VD332ML17TR	16 x 16.5	L17	0.191	1,300

*Refer to diagrams for detailed case size dimensions.

Standard Voltage Ratings - Surface Mount

Rated Voltage (WVDC)	Capacitance (µF)	Catalog Part Number	Nominal Case Size* D × L (mm)	Case Code	Maximum ESR (Ω) at +20°C, 120Hz	Rated Ripple Current (mA rms) at +85°C, 120Hz
10 Volts 13 Volts Surge	4,700	MVA10VD472ML22TR	16 × 21.5	L22	0.141	1,550
	4,700	MVA10VD472MM17TR	18 × 16.5	M17	0.141	1,600
	6,800	MVA10VD682MM22TR	18 × 21.5	M22	0.107	1,850
16 Volts 20 Volts Surge	22	MVA16VC22RMD55TP	4 × 5.2	D55	19.589	26
	33	MVA16VC33RME55TP	5 × 5.2	E55	13.059	37
	47	MVA16VC47RME55TP	5 × 5.2	E55	9.169	44
	100	MVA16VC101MF55TP	6.3 × 5.2	F55	4.31	70
	150	MVA16VC151MF80TP	6.3 × 7.7	F80	2.873	110
	220	MVA16VC221MF80TP	6.3 × 7.7	F80	1.959	130
	330	MVA16VC331MH10TP	8 × 10	H10	1.306	270
	470	MVA16VC471MH10TP	8 × 10	H10	0.917	280
	680	MVA16VC681MJ10TP	10 × 10	J10	0.634	380
	1,000	MVA16VC102MK14TP	12.5 × 13.5	K14	0.497	710
	2,200	MVA16VD222ML17TR	16 × 16.5	L17	0.241	1,150
	3,300	MVA16VD332ML22TR	16 × 21.5	L22	0.171	1,450
	3,300	MVA16VD332MM17TR	18 × 16.5	M17	0.171	1,450
4,700	MVA16VD472MM22TR	18 × 21.5	M22	0.127	1,750	
25 Volts 32 Volts Surge	10	MVA25VC10RMD55TP	4 × 5.2	D55	26.52	24
	22	MVA25VC22RME55TP	5 × 5.2	E55	12.055	41
	33	MVA25VC33RME55TP	5 × 5.2	E55	8.036	47
	47	MVA25VC47RMF55TP	6.3 × 5.2	F55	5.643	60
	56	MVA25VC56RMF55TP	6.3 × 5.2	F55	4.736	66
	100	MVA25VC101MF80TP	6.3 × 7.7	F80	2.652	120
	150	MVA25VC151MH10TP	8 × 10	H10	1.768	210
	220	MVA25VC221MH10TP	8 × 10	H10	1.205	260
	330	MVA25VC331MH10TP	8 × 10	H10	0.804	300
	470	MVA25VC471MJ10TP	10 × 10	J10	0.564	400
	1,000	MVA25VC102MK14TP	12.5 × 13.5	K14	0.431	820
	2,200	MVA25VD222ML22TR	16 × 21.5	L22	0.211	1,450
	2,200	MVA25VD222MM17TR	18 × 16.5	M17	0.211	1,400
3,300	MVA25VD332MM22TR	18 × 21.5	M22	0.151	1,800	
35 Volts 44 Volts Surge	4.7	MVA35VC4R7MD55TP	4 × 5.2	D55	49.372	18
	10	MVA35VC10RMD55TP	4 × 5.2	D55	23.205	24
	22	MVA35VC22RME55TP	5 × 5.2	E55	10.548	41
	33	MVA35VC33RMF55TP	6.3 × 5.2	F55	7.032	54
	47	MVA35VC47RMF60TP	6.3 × 5.7	F60	4.937	64
	100	MVA35VC101MF80TP	6.3 × 7.7	F80	2.321	120
	150	MVA35VC151MH10TP	8 × 10	H10	1.547	210
	220	MVA35VC221MH10TP	8 × 10	H10	1.055	260
	330	MVA35VC331MJ10TP	10 × 10	J10	0.703	360
	470	MVA35VC471MK14TP	12.5 × 13.5	K14	0.776	600
	1,000	MVA35VD102ML17TR	16 × 16.5	L17	0.365	1,100
2,200	MVA35VD222MM22TR	18 × 21.5	M22	0.181	1,700	
50 Volts 63 Volts Surge	3.3	MVA50VC3R3MD55TP	4 × 5.2	D55	60.273	15
	4.7	MVA50VC4R7MD55TP	4 × 5.2	D55	42.319	18
	10	MVA50VC10RME55TP	5 × 5.2	E55	19.89	30
	22	MVA50VC22RMF55TP	6.3 × 5.2	F55	9.041	47
	33	MVA50VC33RMF80TP	6.3 × 7.7	F80	6.027	70
	47	MVA50VC47RMF80TP	6.3 × 7.7	F80	4.232	85
	100	MVA50VC101MH10TP	8 × 10	H10	1.989	190
	220	MVA50VC221MJ10TP	10 × 10	J10	0.904	320
	330	MVA50VC331MK14TP	12.5 × 13.5	K14	0.904	600
	470	MVA50VC471MK16TP	12.5 × 16	K16	0.635	740
	470	MVA50VD471ML17TR	16 × 16.5	L17	0.635	850
	1,000	MVA50VD102ML22TR	16 × 21.5	L22	0.298	1,300
	1,000	MVA50VD102MM22TR	18 × 21.5	M22	0.298	1,400

*Refer to diagrams for detailed case size dimensions.

Standard Voltage Ratings - Surface Mount

Rated Voltage (WVDC)	Capacitance (µF)	Catalog Part Number	Nominal Case Size* D × L (mm)	Case Code	Maximum ESR (Ω) at +20°C, 120Hz	Rated Ripple Current (mA rms) at +85°C, 120Hz
63 Volts 79 Volts Surge	0.10	MVA63VCR10MD55TP	4 × 5.2	D55	1,989.0	1.3
	0.22	MVA63VCR22MD55TP	4 × 5.2	D55	904.091	3
	0.33	MVA63VCR33MD55TP	4 × 5.2	D55	602.727	4
	0.47	MVA63VCR47MD55TP	4 × 5.2	D55	423.191	5
	1.0	MVA63VC1R0MD55TP	4 × 5.2	D55	198.9	8
	2.2	MVA63VC2R2MD55TP	4 × 5.2	D55	90.409	12
	3.3	MVA63VC3R3ME55TP	5 × 5.2	E55	60.273	17
	4.7	MVA63VC4R7ME55TP	5 × 5.2	E55	42.319	20
	10	MVA63VC10RMF55TP	6.3 × 5.2	F55	19.89	32
	22	MVA63VC22RMF80TP	6.3 × 7.7	F80	9.041	60
	33	MVA63VC33RMH10TP	8 × 10	H10	6.027	110
	47	MVA63VC47RMH10TP	8 × 10	H10	4.232	130
	56	MVA63VC56RMJ10TP	10 × 10	J10	3.552	160
	68	MVA63VC68RMJ10TP	10 × 10	J10	2.925	170
	100	MVA63VC101MK14TP	12.5 × 13.5	K14	2.321	380
	220	MVA63VC221MK14TP	12.5 × 13.5	K14	1.055	580
	330	MVA63VC331MK16TP	12.5 × 16	K16	0.703	720
330	MVA63VD331ML17TR	16 × 16.5	L17	0.703	820	
470	MVA63VD471ML17TR	16 × 16.5	L17	0.494	950	
470	MVA63VD471MM17TR	18 × 16.5	M17	0.494	1,000	
100 Volts 125 Volts Surge Not Solvent Proof	22	MVA100VC22RMH10TP	8 × 10	H10	9.041	90
	33	MVA100VC33RMJ10TP	10 × 10	J10	6.027	120
	68	MVA100VC68RMK14TP	12.5 × 13.5	K14	2.438	380
	100	MVA100VC101MK14TP	12.5 × 13.5	K14	1.658	440
	220	MVA100VD221ML22TR	16 × 21.5	L22	0.753	850
	220	MVA100VD221MM17TR	18 × 16.5	M17	0.753	800
	330	MVA100VD331MM22TR	18 × 21.5	M22	0.502	1,000
160 Volts 200 Volts Surge Not Solvent Proof	47	MVA160VC47RMK16TP	12.5 × 16	K16	7.053	370
	68	MVA160VD68RML17TR	16 × 16.5	L17	4.875	500
	100	MVA160VD101ML22TR	16 × 21.5	L22	3.315	590
	100	MVA160VD101MM17TR	18 × 16.5	M17	3.315	590
200 Volts 250 Volts Surge Not Solvent Proof	22	MVA200VC22RMK14TP	12.5 × 13.5	K14	15.068	240
	33	MVA200VC33RMK16TP	12.5 × 16	K16	10.045	310
	47	MVA200VD47RML17TR	16 × 16.5	L17	7.053	420
	68	MVA200VD68RML22TR	16 × 21.5	L22	4.875	510
	68	MVA200VD68RMM17TR	18 × 16.5	M17	4.875	510
	100	MVA200VD101MM22TR	18 × 21.5	M22	3.315	590
250 Volts 300 Volts Surge Not Solvent Proof	10	MVA250VC10RMK14TP	12.5 × 13.5	K14	33.15	150
	22	MVA250VC22RMK16TP	12.5 × 16	K16	15.068	240
	33	MVA250VD33RML17TR	16 × 16.5	L17	10.045	340
	47	MVA250VD47RML22TR	16 × 21.5	L22	7.053	420
	47	MVA250VD47RMM17TR	18 × 16.5	M17	7.053	420
	68	MVA250VD68RMM22TR	18 × 21.5	M22	4.875	490
400 Volts 450 Volts Surge Not Solvent Proof	4.7	MVA400VC4R7MK14TP	12.5 × 13.5	K14	88.165	120
	10	MVA400VD10RML17TR	16 × 16.5	L17	41.438	140
	22	MVA400VD22RML22TR	16 × 21.5	L22	18.835	280
	22	MVA400VD22RMM17TR	18 × 16.5	M17	18.835	280
	33	MVA400VD33RMM22TR	18 × 21.5	M22	12.557	350
450 Volts 500 Volts Surge Not Solvent Proof	4.7	MVA450VC4R7MK14TP	12.5 × 13.5	K14	88.165	120
	10	MVA450VD10RML17TR	16 × 16.5	L17	41.438	140
	22	MVA450VD22RML22TR	16 × 21.5	L22	18.835	280
	33	MVA450VD33RMM22TR	18 × 21.5	M22	12.557	350

*Refer to diagrams for detailed case size dimensions.