

A1RFRD10

| REVISION RECORD | | | | |
|-----------------|-----|-------------|----------------|------|
| REV | ECO | DESCRIPTION | DRFT | CHKD |
| △ | | ADD P/N | JMY 9/28/05 | |
| △ | | ADD DIM | AWR 9/29/05 | |
| △ | | ADD P/N. | AWR 2/25/06 | |

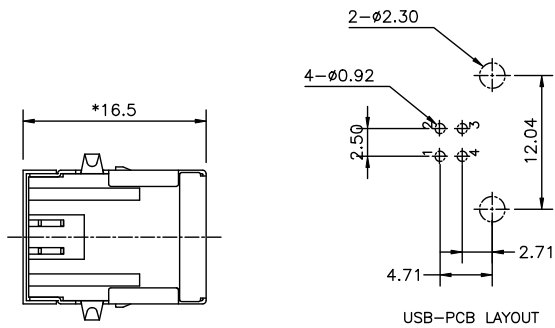
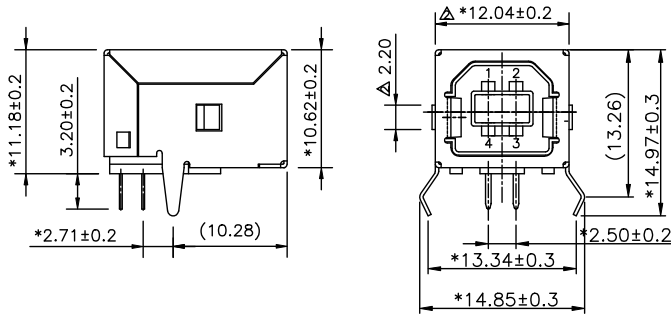

NOTES:

- MATERIAL:
 TERMINAL-C5191 PHOSPHOR BRONZE HARD. (t=0.25mm)
 SHIELD-COPPER ALLOY(t=0.30mm)
 HOUSING-PBT+30% G.F. UL94V-0
 - PLATING: CONTACT-GOLD PLATING OVER NICKEL
 SHIELD-120u" TIN MIN OVER 50u" NICKEL.
 OR 100u"~120u" NICKEL OVER 40u" Cu.
 - GAP. 0.25mm (Max.)
 - ELECTRICAL:
 VOLTAGE RATING : 30 VAC RMS.
 CURRENT RATING : 1.0 AMP
 CONTACT RESISTANCE : 30 MILLIOHMS MAX
 INSULATION RESISTANCE : 1000 MEGOHMS MIN @500 VDC
 DIELECTRIC STRENGTH : 750 VAC RMS 60 HZ, 1 MIN
 OPERATING LIFE : 1500 CYCLES MIN
 MATING FORCE : 3.5 KGS MAX
 UNMATING FORCE : 1 KGS MIN
 - ENVIRONMENTAL:
 STORAGE : -40° C TO +85° C
 OPERATION : 0° C TO 70° C
 CAPACITANCE : 2 PF MAX 1KHZ
 - WAVE SOLDER TEMPERATURE: 230-250°C.(5-10 SECONDS)
 - UL & CUL FILE NO. E163191
 - ROHS PART NUMBER: E8144-BOX2X-L
- 1-NICKEL
 2-TIN
 0-PBT BLACK
 3-PBT WHITE
 △A-PBT LUMINOUS BLUE
 △E-PBT BLUE
- 1-Au3u"
 2-Au6u"
 4-Au30u"
 7-Pd30u"

| | | | | | |
|----------------------------|---|----------------------------|----------------|-------------------------------|--|
| MM (INCH) | | DPTO SAMMY DATE 03/14/05 | | FULL RISE ELECTRONIC CO., LTD | |
| TOLERANCES EXCEPT AS NOTED | | CHKD/SHELLY DATE 2006/2/25 | | | |
| MM | ± | MFD | DATE | TITLE USB Series B | |
| .0 ±0.20 | ± | APPV/LUSHENG | DATE 2006/2/25 | 4-Position Dip Type | |
| .00 ±0.15 | ± | MATERIAL : | | DRAWING NO. GE813A02-LC | |
| .000 ±0.075 | ± | ANGLES ± | | /PART NO. SEE NOTE | |
| THIRD ANGLE PROJECTION | | FINISH : | | SIZE A3 | |
| | | SCALE : | | REV 3 | |
| | | | | DO NOT SCALE DRAWING | |
| | | | | SHEET X OF Y | |

8 | 7 | 6 | 5 | 4 | 3 | 2 | 1