

A1RFRD10

REVISION RECORD				
REV	ECO	DESCRIPTION	DRFT	CHKD
△		ADD P/N	SAMMY 07/03/05	
△		ADD P/N	SAMMY 08/03/05	
△		ADD DIM	ANKLE 09/30/05	
△		MODIFY NOTE.	ANKLE 10/18/05	
△		DRAWING CHANGE	SHYCHEN 07/22/06	

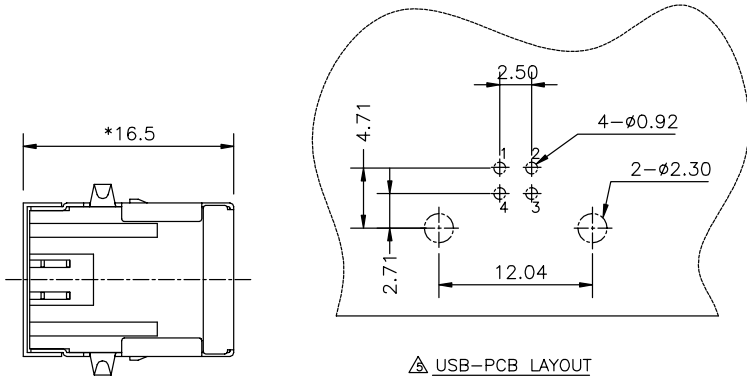
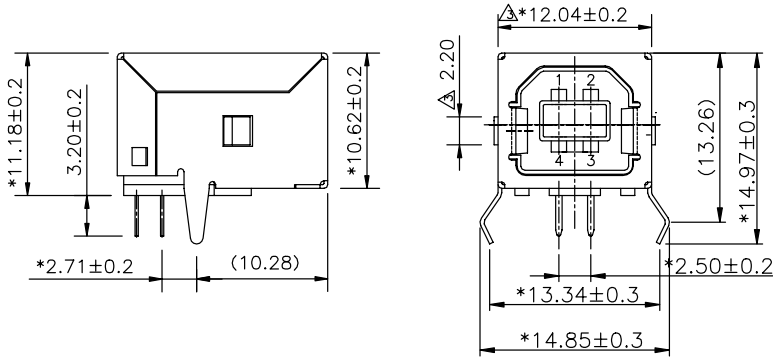

△ USB-PCB LAYOUT

NOTES:

- MATERIAL:
TERMINAL—C5191 PHOSPHOR BRONZE HARD. (t=0.25mm)
SHIELD—COPPER ALLOY(t=0.30mm)
HOUSING—NYLOY+GF30%
 - PLATING: CONTACT—GOLD PLATING OVER NICKEL
SHIELD—NICKEL OVER Cu.
 - GAP, 0.25mm (Max.)
 - ELECTRICAL:
VOLTAGE RATING : 30 VAC RMS.
CURRENT RATING : 1.0 AMP
CONTACT RESISTANCE : 30 MILLIOHMS MAX
INSULATION RESISTANCE : 1000 MEGOHMS MIN @500 VDC
DIELECTRIC STRENGTH : 750 VAC RMS 60 HZ, 1 MIN
OPERATING LIFE : 1500 CYCLES MIN
MATING FORCE : 3.5 KGS MAX
UNMATING FORCE : 1 KGS MIN
 - ENVIRONMENTAL:
STORAGE : -40°C TO +85°C
OPERATION : -40°C TO +85°C
CAPACITANCE : 2 PF MAX 1KHZ
WAVE SOLDER TEMPERATURE: 255-265°C.(5-10 SECOND)
 - RoHS COMPLIANT.
 - UL & CUL FILE NO. E163191
 - RoHS PART NUMBER: E8144-B0XX2X-L
- △ MATERIAL AND COLOR:
1H—FR52 PANTONE BLUE 285C
14—FR52 WHITE
1D—PA9T BLACK
15—FR52 BLACK
- 1—Au3u" 2—Au6u"
4—Au30u" 5—Au50u" △
7—Pd30u"

MM (INCH)		DFTO SAMMY	DATE 03/14/05
TOLERANCES EXCEPT AS NOTED		CHKDANKUE	DATE 2006/7/22
		MFO	DATE
		APPLV LUSHENG	DATE 2006/7/22
MATERIAL :			
ANGLES ± 0.5		QTY :	
THIRD ANGLE PROJECTION		FINISH :	
		SCALE : 3:1	

Pulse A TECHNOLOGY COMPANY		RoHS Compliant	
FULL RISE ELECTRONIC CO., LTD			
TITLE USB Series B 4-Position Dip Type			
DRAWING NO. GE813A02-LA		SIZE A3	REV 5
/PART NO. SEE NOTE		DO NOT SCALE DRAWING	
SHEET 1		OF 1	

8 | 7 | 6 | 5 | 4 | 3 | 2 | 1